

KEY SHOWN IN POSITION "B"

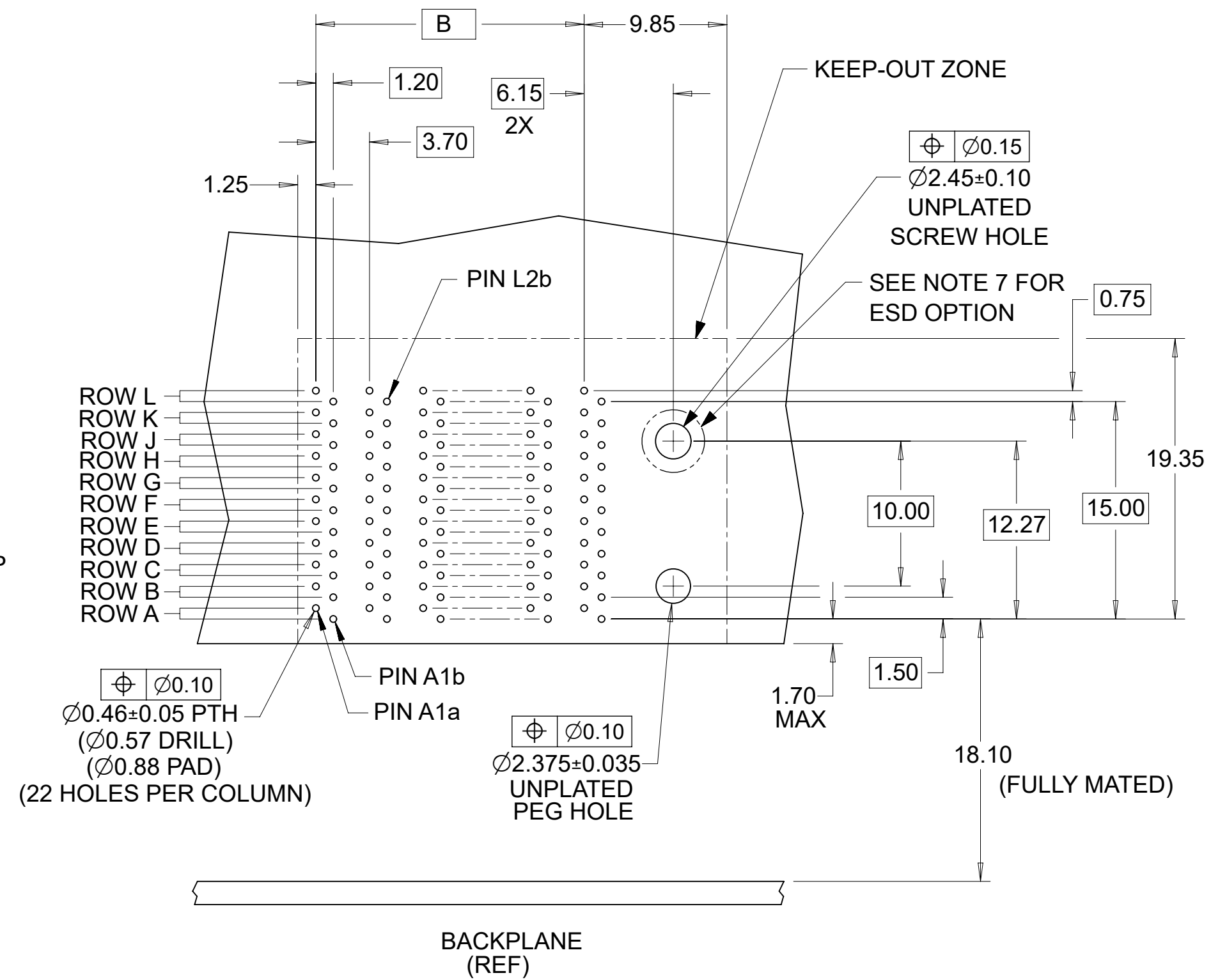
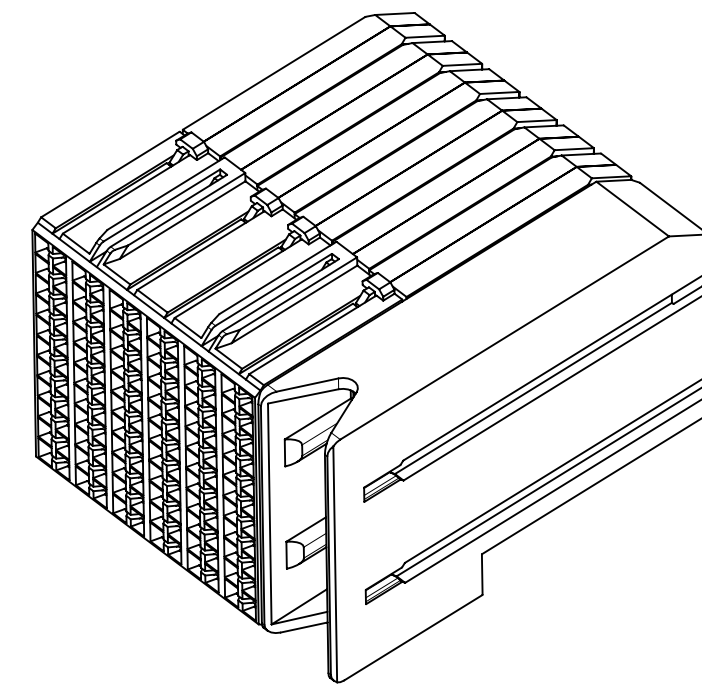
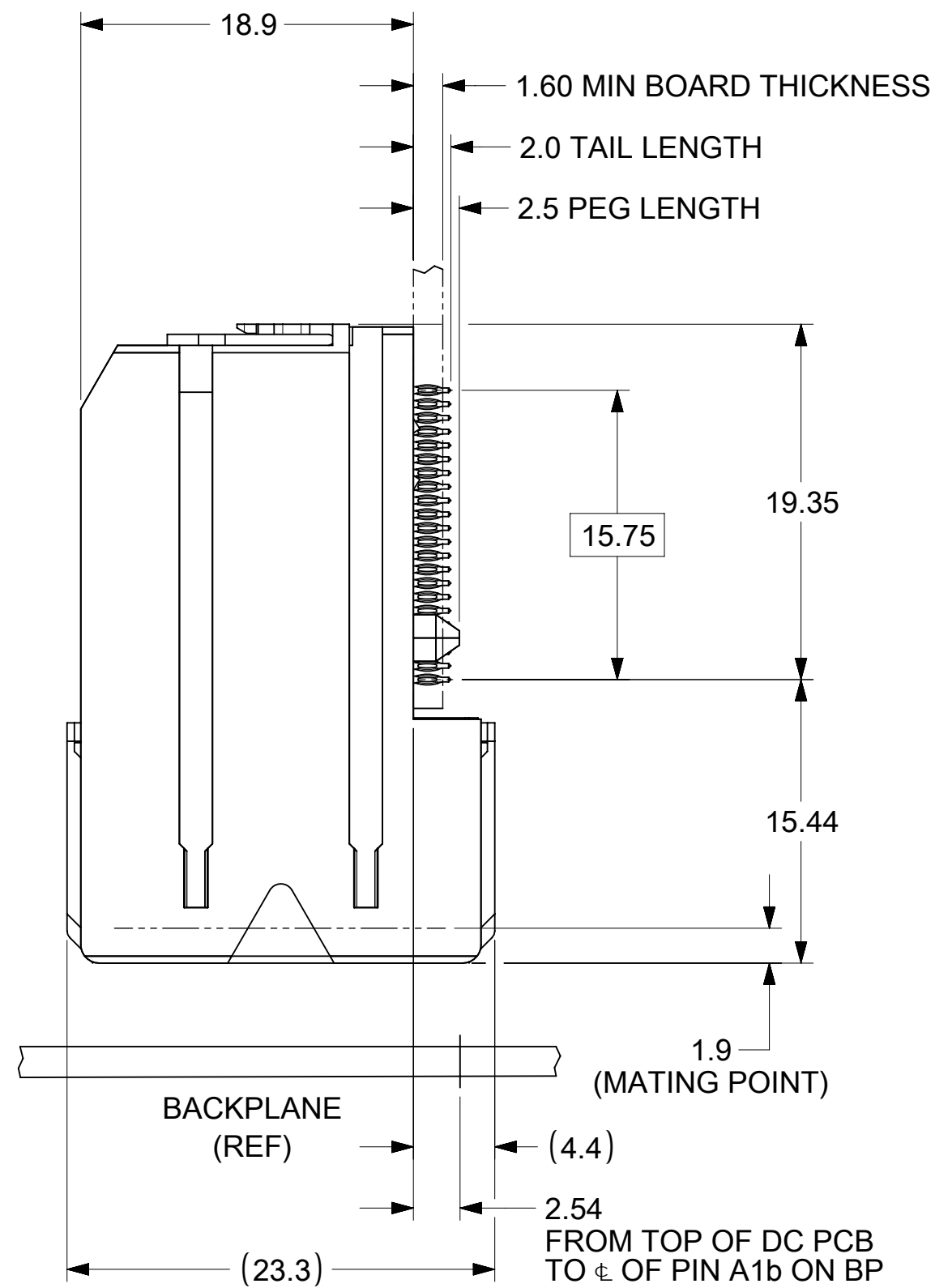

DAUGHTERCARD HOLE PATTERN (CONNECTOR SIDE)

NOTES:

1. MATERIALS: HOUSING - LIQUID CRYSTAL POLYMER (LCP) GLASS-FILLED, UL94V-0
TERMINALS - HIGH PERFORMANCE COPPER ALLOY
2. FINISH: SELECTIVE GOLD IN CONTACT AREA.
SELECTIVE MATTE TIN ON PCB TAILS. NICKEL OVERALL
3. REFER TO MOLEX PRODUCT SPECIFICATION PS-75710-999 FOR PERFORMANCE SPECS.
4. PRODUCT IS PACKAGED PER PK-70873-609.
5. THIS PART CONFORMS TO CLASS B REQUIREMENTS OF COSMETIC SPEC PS-45499-002.
6. GUIDED PARTS TO BE SHIPPED WITH 2-32 TYPE AB
SELF-TAPPING SCREW P/N 73726-0000.
7. FOR GROUNDED GUIDE MODULES USE DIA 2.45+/-0.10 (PTH), DIA 2.58 (DRILL).
AND DIA 4.50 (PAD)
8. MAPS (MOLEX ADVANCED PLATING SYSTEM)

THIS DRAWING CONTAINS INFORMATION THAT IS PROPRIETARY TO MOLEX ELECTRONIC TECHNOLOGIES, LLC AND SHOULD NOT BE USED WITHOUT WRITTEN PERMISSION

DIMENSION UNITS	SCALE	CURRENT REV DESC:	molex			
mm	NTS	REMASTERED TO NX	I-TRAC DAUGHTERCARD 11 ROW SIGNAL MODULE GUIDE RIGHT SALES DWG			
GENERAL TOLERANCES (UNLESS SPECIFIED)		EC NO: 671119	PRODUCT CUSTOMER DRAWING			
ANGULAR TOL	± 0.5°	DRWN: YOGEEB	2021/06/28	DOCUMENT NUMBER	DOC TYPE	DOC PART
4 PLACES	±	CHK'D: VINODM3	2022/01/31	SD-75710-004	PSD	001
3 PLACES	±	APPR: CWANG25	2022/02/18			E1
2 PLACES	± 0.13	INITIAL REVISION:		MATERIAL NUMBER	CUSTOMER	SHEET NUMBER
1 PLACE	± 0.25	DRWN: MCARRANZA	2006/06/19	SEE TABLE	GENERAL MARKET	1 OF 2
0 PLACES	±	APPR: JLAURX	2006/06/21			
DRAFT WHERE APPLICABLE MUST REMAIN WITHIN DIMENSIONS	THIRD ANGLE PROJECTION	DRAWING	SERIES			
		C-SIZE	75710			

75710- * * * *

MODULE TYPE -- TAIL PLATING TYPE
 GUIDE RIGHT -- MATTE TIN (FORMERLY TIN/LEAD) = 4
 GUIDE RIGHT -- MATTE TIN = 5

POLARIZATION KEY ORIENTATION

0 = NO KEY
 1 = A 5 = E
 2 = B 6 = F
 3 = C 7 = G
 4 = D 8 = H

OF COLUMNS/PLATING

05 = 5 COL 30 GOLD
 06 = 6 COL 30 GOLD
 08 = 8 COL 30 GOLD
 10 = 10 COL 30 GOLD
 55 = 5 COL W/ESD 30 GOLD
 56 = 6 COL W/ESD 30 GOLD
 58 = 8 COL W/ESD 30 GOLD
 50 = 10 COL W/ESD 30 GOLD
 25 = 5 COL 10 GOLD (MAPS)
 26 = 6 COL 10 GOLD (MAPS)
 28 = 8 COL 10 GOLD (MAPS)
 20 = 10 COL 10 GOLD (MAPS)
 65 = 5 COL W/ESD 10 GOLD (MAPS)
 66 = 6 COL W/ESD 10 GOLD (MAPS)
 68 = 8 COL W/ESD 10 GOLD (MAPS)
 60 = 10 COL W/ESD 10 GOLD (MAPS)

MATERIAL NUMBER	# OF COLUMNS	DIM "A" MAX	DIM "B"
75710-***5	5	25.90	14.80
75710-***6	6	29.60	18.50
75710-***8	8	37.00	25.90
75710-***0	10	44.40	33.30

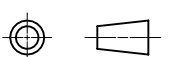
THIS DRAWING CONTAINS INFORMATION THAT IS PROPRIETARY TO MOLEX ELECTRONIC TECHNOLOGIES, LLC AND SHOULD NOT BE USED WITHOUT WRITTEN PERMISSION											
DIMENSION UNITS mm		SCALE NTS		CURRENT REV DESC: REMASTERED TO NX							
GENERAL TOLERANCES (UNLESS SPECIFIED)				EC NO: 671119 DRWN: YOGEEB 2021/06/28 CHK'D: VINODM3 2022/01/31 APPR: CWANG25 2022/02/18							
ANGULAR TOL ± 0.5°		4 PLACES ±						INITIAL REVISION: DRWN: MCARRANZA 2006/06/19 APPR: JLAURX 2006/06/21			
3 PLACES ±		2 PLACES ± 0.13		DOCUMENT NUMBER SD-75710-004		DOC TYPE PSD					
1 PLACE ± 0.25		0 PLACES ±		MATERIAL NUMBER SEE TABLE		CUSTOMER GENERAL MARKET		SHEET NUMBER 2 OF 2			
DRAFT WHERE APPLICABLE MUST REMAIN WITHIN DIMENSIONS				THIRD ANGLE PROJECTION 		DRAWING C-SIZE		SERIES 75710			