

Device Name: BGGP 6330 (N)(H)

Date : 08/20/2015

Mechanical Data :

Rev Date : Index #:

ISSUED BY : Zhan Sam

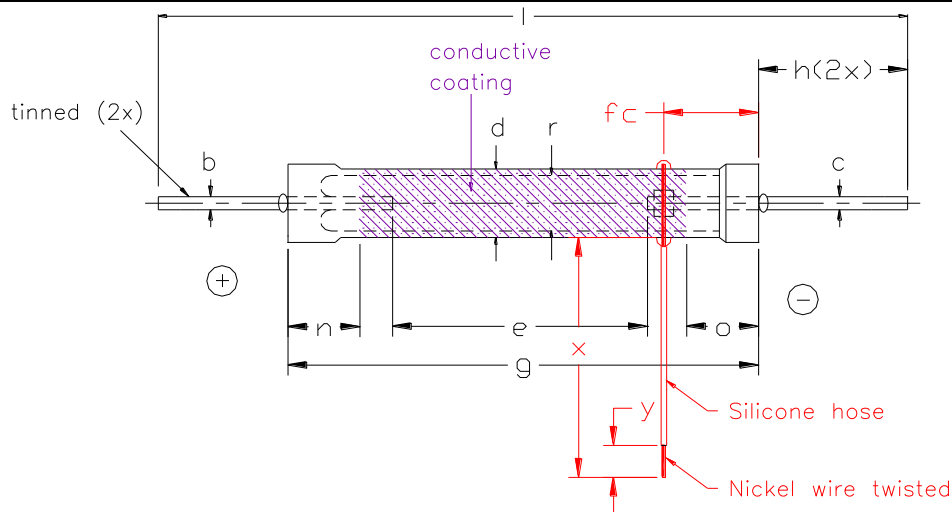

e	30+/-1	b	1.2+/-0.1	x	50+/-5
g	44.5+/-1	c	0.8+/-0.1	y	6+/-3
l	50.5+/-1	n/o	4.0+/-0.8		
d	4.0+/-0.2	fc	6.0+/-1		
r	2.4+/-0.1	h	3+/-1		

Without Colour Corrective Coating:

Remarks : Envelop material: B2
RoHS complaints
Excelitas bau#: 96324720

Operating Data :

Type of Circuit : Doubler

Max flash energy Emax/Ws	49	Trigger coil Tr	ZS 1052(H)
Nom flash energy Enom/Ws		Trigger capacitor Cz/μF	0.22
Max anode voltage Uamax/V	350	Min trigger voltage Uzmin/V	250
Nom anode voltage Uanom/V	325	Trigger contact S	SCR
Min anode voltage Uamin/V	300	Repetition rate /Frequency	5 sec
Nom flash capacitor CB/μF	800	Life/Number of flashes/N	*TBD
Series resistor R/m W		Light reduction after life/%	< 10
Series inductance L/μH		Sec trigger voltage Uzsec/kV	- 10.8
Max Ipeak /A at Ua =			

Customer Reference :

Remarks : *life @ Enom, Treq=5 sec, life flashes is to be determined

Excelitas Proprietary & Confidential

HS-DDC-H24-0003
Excelitas
www.excelitas.com