

REVISIONS					
REV	ECO	DESCRIPTION	DATE	BY	APPR
A1	-	RELEASE NEW DRAWING	15JUN18	SULLEN	TOMMY
A2	-	REVISED DRAWING	10JUL20	JHEAD	DH

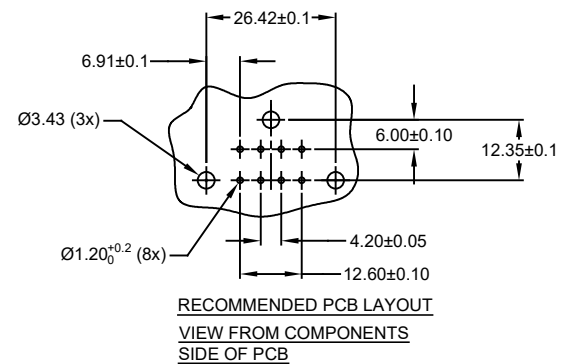
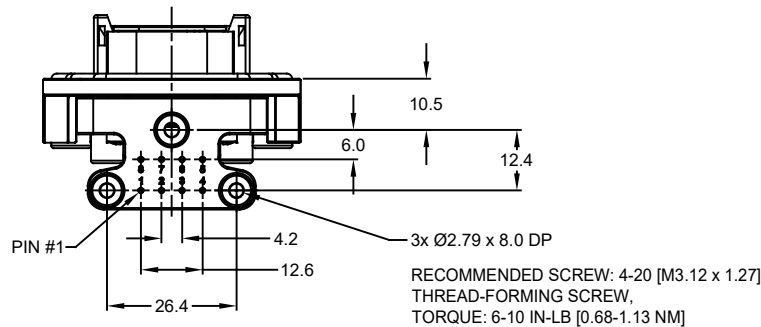
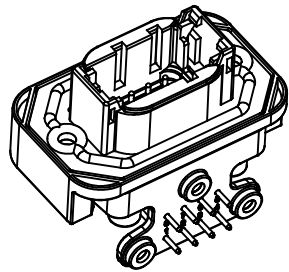
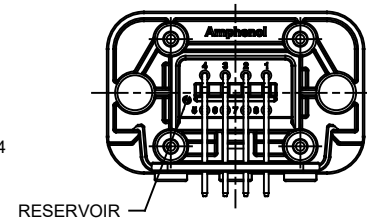
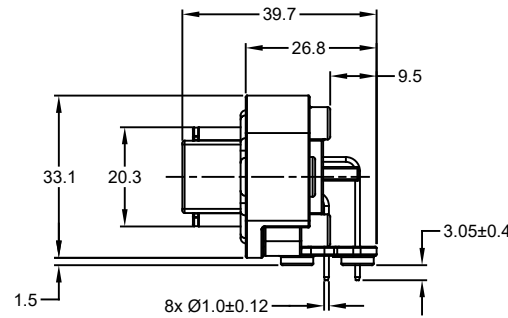
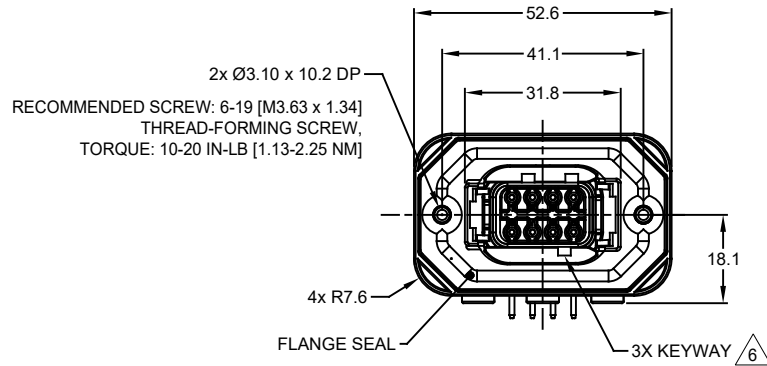

NOTES: UNLESS OTHERWISE SPECIFIED

- MATERIAL:  
 HOUSING: THERMOPLASTIC, GREY  
 SEAL: SILICONE RUBBER  
 CONTACT: COPPER ALLOY
- CONTACT PLATING: SEE SHEET 2
- MODIFICATIONS: FLANGE; RA PCB MOUNT
- SPECIFICATIONS:  
 4.1 CURRENT RATING: 7.5 AMPS  
 4.2 OPERATING TEMPERATURE: -55°C TO +125°C  
 4.3 DIELECTRIC WITHSTANDING VOLTAGE: LESS THAN 2 MILLIAMPS CURRENT LEAKAGE @ 1500 VOLTS AC  
 4.4 INSULATION RESISTANCE: 1000 MEGOHMS MIN @ 25°C  
 4.5 MOISTURE RESISTANCE: IP67 ( MATED CONDITION )  
 4.6 MATING CYCLE DURABILITY: 100 CYCLES  
 4.7 RoHS COMPLIANT

- MATING PART: ATM06-08SX\*  
 ( X = A,B,C,D KEYS ; \* = MODIFICATIONS AND COLORS )  
 SEE SHEET 2 FOR OTHER KEY ARRANGEMENTS AND COLORS
- ALL DIMENSIONS ARE FOR REFERENCE USE ONLY
- POTTED CONNECTORS SPECIFIED FOR UP TO 5 P.S.I. APPLICATIONS.

ATM13-08PX-BMXX		DESCRIPTION		ITEM
QUANTITY	PART NUMBER	MATERIALS LIST		
UNLESS OTHERWISE SPECIFIED		SIGNATURES		DATE
1) All dimensions are in metric(mm).		DRAWN: SULLENZHANG		15JUN18
2) Tolerances are as follows:		CHECKED: ORIONLI		15JUN18
1 PL DEC ±0.30		ENGINEER:		
2 PL DEC ±0.15		APPROVAL: TOMMY.XIE		15JUN18
3 PL DEC ±0.08		CUSTOMER:		
3) Note reference =		THIS DRAWING IS SUPPLIED FOR INFORMATION ONLY. DESIGN FEATURES, SPECIFICATIONS AND PERFORMANCE DATA SHOWN HEREON ARE THE PROPERTY OF THE AMPHENOL CORPORATION. NO RIGHTS OF REPRODUCTION ARE IMPLIED. ALL DIMENSIONS ARE SUBJECT TO NORMAL MANUFACTURING VARIATIONS.		
MATERIAL SPECIFICATIONS:		SIZE		TYPE
PROCESS SPECIFICATIONS:		B C-		
NEXT ASSY:		DWG NO:		REVISION
		ATM13-08PX-BMXX		A2
		SCALE: NONE		SHEET 1 OF 2

TITLE: PCB MOUNT RECEPTACLE, 8 PIN, RA FLANGE, ATM SERIES  
 DWG NO: ATM13-08PX-BMXX  
 REV: A2  
 SH: 1  
 OF: 2

REVISIONS					
REV	ECO	DESCRIPTION	DATE	BY	APPR
A1	-	RELEASE NEW DRAWING	15JUN18	SULLEN	TOMMY
A2	-	REVISED DRAWING	10JUL20	JHEAD	DH

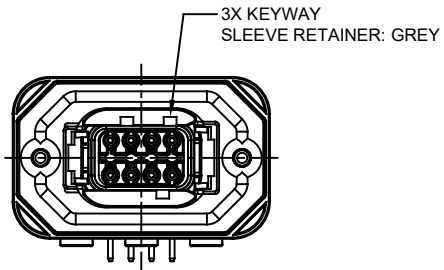

ATM13-08PA-BMXX  
KEY A

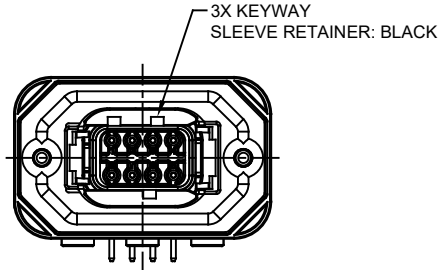

ATM13-08PB-BMXX  
KEY B

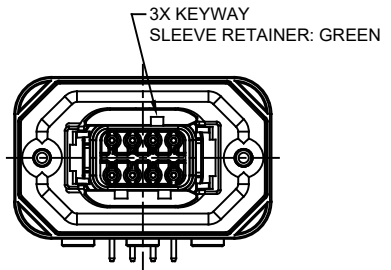

ATM13-08PC-BMXX  
KEY C

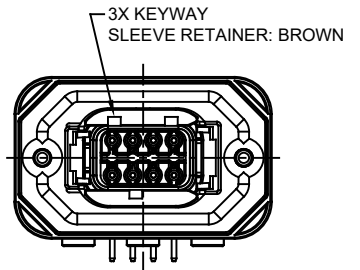

ATM13-08PD-BMXX  
KEY D

ATM13-08PA-BMXX VARIANTS		
CONTACT PLATING	POTTING OR NOT IN RESERVOIR	PART NUMBER
GOLD	NO POTTING	ATM13-08PA-BM01
GOLD	POTTING	ATM13-08PA-BM02
TIN	NO POTTING	ATM13-08PA-BM03
TIN	POTTING	ATM13-08PA-BM04

ATM13-08PB-BMXX VARIANTS		
CONTACT PLATING	POTTING OR NOT IN RESERVOIR	PART NUMBER
GOLD	NO POTTING	ATM13-08PB-BM01
GOLD	POTTING	ATM13-08PB-BM02
TIN	NO POTTING	ATM13-08PB-BM03
TIN	POTTING	ATM13-08PB-BM04

ATM13-08PC-BMXX VARIANTS		
CONTACT PLATING	POTTING OR NOT IN RESERVOIR	PART NUMBER
GOLD	NO POTTING	ATM13-08PC-BM01
GOLD	POTTING	ATM13-08PC-BM02
TIN	NO POTTING	ATM13-08PC-BM03
TIN	POTTING	ATM13-08PC-BM04

ATM13-08PD-BMXX VARIANTS		
CONTACT PLATING	POTTING OR NOT IN RESERVOIR	PART NUMBER
GOLD	NO POTTING	ATM13-08PD-BM01
GOLD	POTTING	ATM13-08PD-BM02
TIN	NO POTTING	ATM13-08PD-BM03
TIN	POTTING	ATM13-08PD-BM04

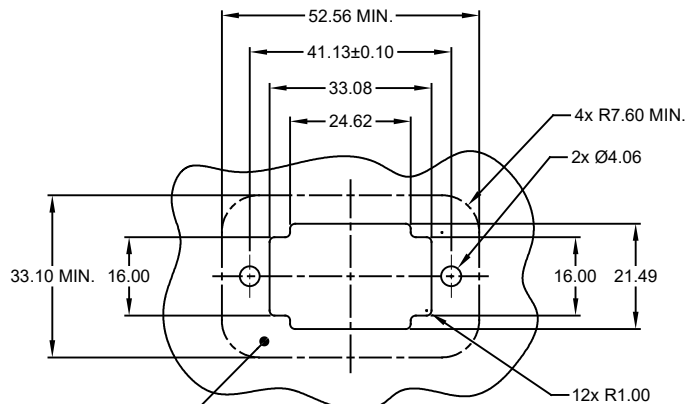

INTERNAL SEALING SURFACE FINISH TO BE  $\geq 3.2$  OR BETTER  $\sqrt{10.13}$

RECOMMENDED PANEL CUTOUT

ATM13-08PX-BMXX		DESCRIPTION		ITEM
QUANTITY	PART NUMBER	MATERIALS LIST		
UNLESS OTHERWISE SPECIFIED		SIGNATURES		DATE
1) All dimensions are in metric (mm).		DRAWN: SULLEN.ZHANG		15JUN18
2) Tolerances are as follows:		CHECKED: ORION.LI		15JUN18
1 PL DEC $\pm 0.30$   Fractions $\pm 1/64$		ENGINEER:		
2 PL DEC $\pm 0.15$   Angles $\pm 1^\circ$		APPROVAL: TOMMY.XIE		15JUN18
3 PL DEC $\pm 0.08$		CUSTOMER:		
3) Note reference = $\Delta$		THIS DRAWING IS SUPPLIED FOR INFORMATION ONLY. DESIGN FEATURES, SPECIFICATIONS AND PERFORMANCE DATA SHOWN HEREON ARE THE PROPERTY OF THE AMPHENOL CORPORATION. NO RIGHTS OF REPRODUCTION ARE IMPLIED. ALL DIMENSIONS ARE SUBJECT TO NORMAL MANUFACTURING VARIATIONS.		
MATERIAL SPECIFICATIONS:		SIZE		
PROCESS SPECIFICATIONS:		TYPE		
NEXT ASSY:		DWG NO:		
		SCALE: NONE		
		SHEET 2 OF 2		

**Amphenol**

Sine Systems - www.amphenol-sine.com  
44724 Morley Drive  
Clinton Township, MI 48036

BOARDLOCK PCB MOUNT RECEPTACLE,  
8 PIN, RA FLANGE, ATM SERIES

SIZE: B C-  
TYPE: ATM13-08PX-BMXX  
DWG NO: A2  
REVISION: A2

TITLE: PCB MOUNT RECEPTACLE 8PIN RA FLANGE ATM SERIES  
DWG NO: ATM13-08PX-BMXX  
REV: A2  
SH: 2  
OF: 2