

# LTC3376

## 20V, 4-Channel Buck DC/DC with 8x Configurable 1.5A Power Stages (Configuration CFG(3:0) = 0000)

### DESCRIPTION

Demonstration Circuit DC2966A shows the [LTC®3376](#) 4-channel configurable buck regulator operating in configuration CFG[3:0] = 0000. This sets the LTC3376 to operate as a quad buck with all four possible outputs, each capable of 3A. By default, outputs 1-4 are set at 5V, 3.3V, 2.5V, and 1.8V, respectively.

Outputs can be enabled, disabled, or sequenced individually. By default, all channel inputs are separate but the board can be configured to power all or some channels from a

common input. Each channel has a PGOOD LED indicator to show that its output is regulating within the desired range. Switching operation can allow burst mode for high-efficiency operation at low load currents but can also be forced to continuous PWM for more deterministic EMI.

The PCB is laid out on 6 layers and the demonstration circuit provides access to all features of the LTC3376.

[Design files for this circuit board are available.](#)

All registered trademarks and trademarks are the property of their respective owners.

### BOARD PHOTO

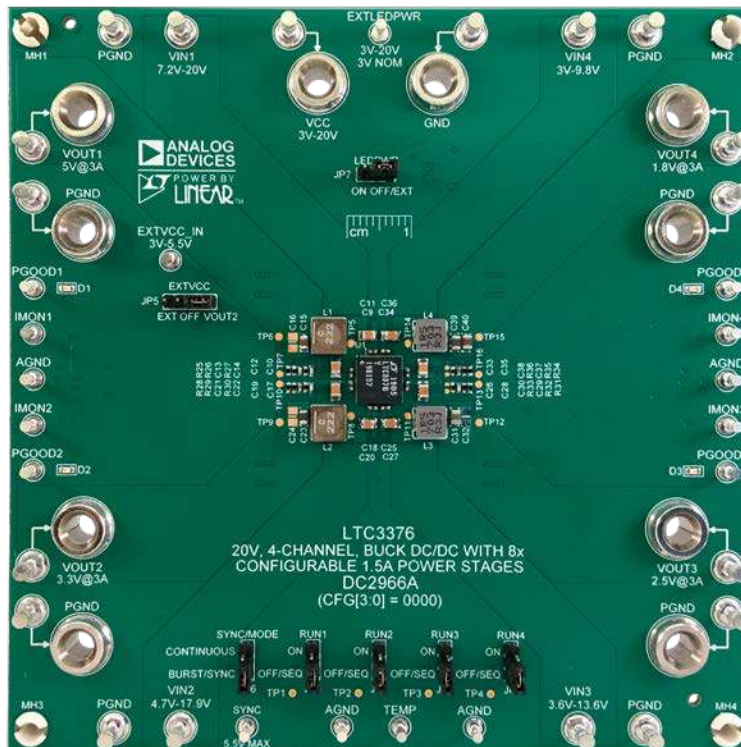

# DEMO MANUAL DC2966A

## PERFORMANCE SUMMARY Specifications are at $T_A = 25^\circ\text{C}$

SYMBOL	PARAMETER	CONDITIONS	MIN	TYP	MAX	UNITS
$V_{CC}$	LTC3376 Power Voltage Range	R39-R42 not installed (default) R39-R42 installed	3 7.2		20 9.8	V
<b>CHANNEL 1</b>						
$V_{IN1}$	Channel 1 Input Voltage Range	Default $V_{OUT1}$ Voltage (5V)	7.2		20	V
$V_{OUT1}$	Channel 1 Output Voltage	Default FB Resistor Values		5		V
$I_{OUT1}$	Channel 1 Output Current Limit			3		A
<b>CHANNEL 2</b>						
$V_{IN2}$	Channel 2 Input Voltage Range	Default $V_{OUT2}$ Voltage (3.3V)	4.7		17.9	V
$V_{OUT2}$	Channel 2 Output Voltage	Default FB Resistor Values		3.3		V
$I_{OUT2}$	Channel 2 Output Current Limit			3		A
<b>CHANNEL 3</b>						
$V_{IN3}$	Channel 3 Input Voltage Range	Default $V_{OUT3}$ Voltage (2.5V)	3.6		13.6	V
$V_{OUT3}$	Channel 3 Output Voltage	Default FB Resistor Values		2.5		V
$I_{OUT3}$	Channel 3 Output Current Limit			3		A
<b>CHANNEL 4</b>						
$V_{IN4}$	Channel 4 Input Voltage Range	Default $V_{OUT4}$ Voltage (1.8V)	3		9.8	V
$V_{OUT4}$	Channel 4 Output Voltage	Default FB Resistor Values		1.8		V
$I_{OUT4}$	Channel 4 Output Current Limit			3		A

## TYPICAL APPLICATION

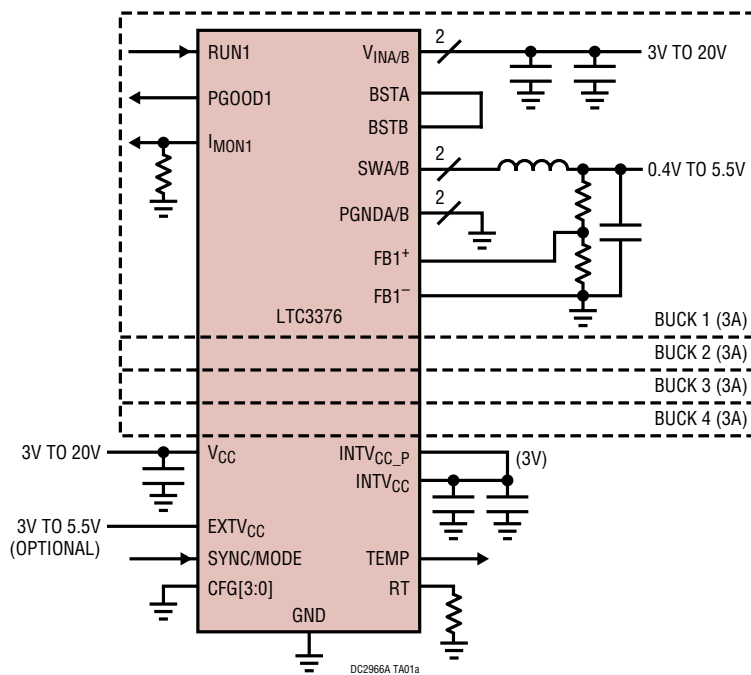

## QUICK START PROCEDURE

Follow the procedure below to familiarize yourself with the DC2966A.

1. Configure the board as follows:

- JP1-JP4 OFF
- JP5 OFF
- JP6 BURST/SYNC
- JP7 ON
- R39-R42 not installed

2. Choose one of the four channels to test and connect test equipment to that channel based on Figure 1. Figure 1 is configured to test channel 1 but moving the lab equipment respectively to other outputs (or all outputs) allows those to be tested instead.

For your chosen channel, x, PS1 should be on  $V_{INx}$  and  $V_{M1}$  / LD1 should be on  $V_{OUTx}$ . Adjust the PS1 voltage to any voltage in the range shown on the chosen  $V_{INx}$  input turret.

3. Enable power from PS2 & PS1 and note that  $V_{M1}$  reads 0V.

4. Put the jumper of JP1-JP4 relevant to your chosen channel in the ON position to enable the relevant  $RUNx$  pin. Note that  $V_{M1}$  reads your chosen output voltage:

- $V_{OUT1}$  5V
- $V_{OUT2}$  3.3V
- $V_{OUT3}$  2.5V
- $V_{OUT4}$  1.8V

Also note that the  $PGOODx$  LED corresponding to your chosen output is now lit.

5. Enable LD1 and observe that  $V_{OUTx}$  maintains regulation and  $V_{M1}$  reads the same output voltage.

6. Optional: try cascading bucks; connect  $V_{OUT1}$  to  $V_{IN2}$  and  $V_{OUT2}$  to  $V_{IN4}$ , set  $RUN1$ ,  $RUN2$ , and  $RUN4$  to ON, then measure 1.8V on  $V_{OUT4}$ . Also, consider repeating this procedure with other outputs or with multiple outputs running simultaneously.

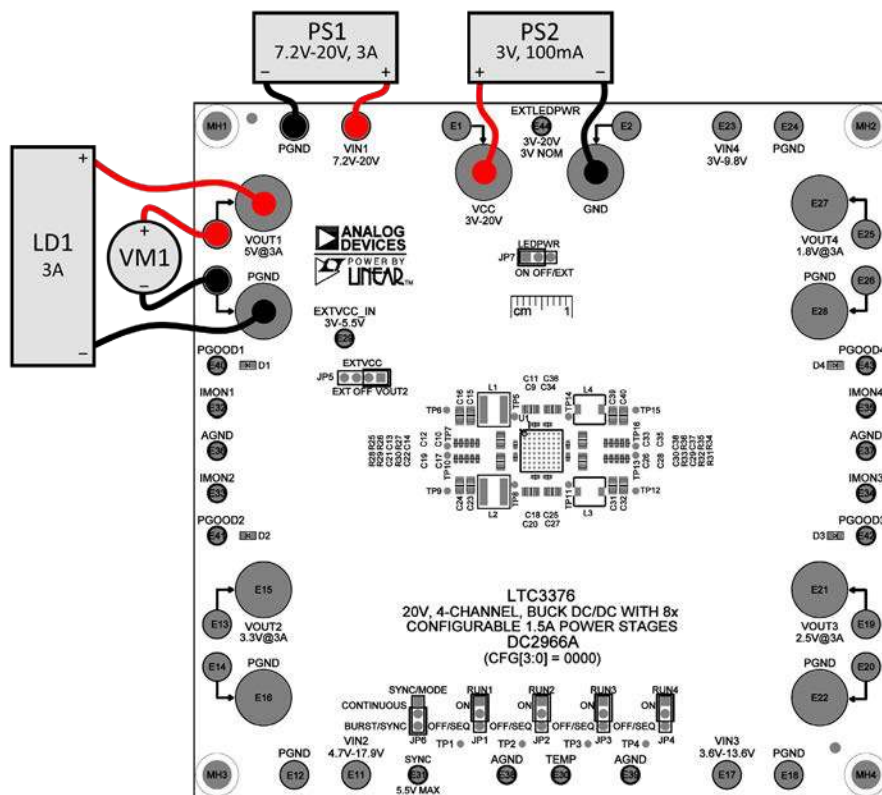

Figure 1. Quick Start Setup for the DC2966A Demo Circuit

## JUMPER DESCRIPTIONS

**Table 1. Jumper Function Descriptions**

JUMPER	NAME	FUNCTION	POSITIONS	POSITION DESCRIPTION
JP1-JP4	RUN1-RUN4	Enables outputs 1-4 respectively	ON	Output enabled
			OFF/SEQ	Output disabled or sequenced (see Sequencing section)
JP5	EXTV <sub>CC</sub>	Determines EXTV <sub>CC</sub> source	V <sub>OUT2</sub>	EXTV <sub>CC</sub> powered by the LTC3376's V <sub>OUT2</sub> output (3.3V default) turret
			OFF	EXTV <sub>CC</sub> not powered externally
			EXT	EXTV <sub>CC</sub> powered by a source connected to EXTV <sub>CC_IN</sub>
JP6	SYNC/MODE	Sets continuous, burst, or sync mode	CONTINUOUS	Forced continuous PWM operation
			BURST/SYNC	Burst mode allowed, will sync to a PWM input on SYNC turret
JP7	LEDPWR	Determines LED power source	ON	LEDs powered from V <sub>CC</sub>
			OFF/EXT	LEDs powered by a source connected to EXTLEDPWR turret

## DEMO CIRCUIT OPERATION

### Introduction to the DC2966A

The DC2966A demonstration circuit features the LTC3376, a step-down multi-output monolithic buck regulator. This demo circuit puts the LTC3376 into configuration CFG[3:0] = 0000. As such, LTC3376 will utilize all four possible outputs, each with a current limit of 3A. V<sub>OUT1</sub>-V<sub>OUT4</sub> have default output voltages of 5V, 3.3V, 2.5V, and 1.8V, respectively. These voltages are configured using voltage dividers on the FB pins and can be changed by the user.

Each output of the LTC3376 has its own separate input and these must be supplied separately by default on the demo circuit. Optionally, R39-R42 can be installed to power all outputs from the V<sub>CC</sub> input, therefore requiring only one supply to operate the board (refer to Ganging Inputs Section).

All LTC3376 monitoring pins are accessible through small turrets near the edges of the board. Configurable options (except for the CFG[3:0] pins) can be modified using jumpers. Refer to the Jumper Descriptions section of this demo manual for further information.

### Demo Circuit Layout

The CFG[3:0] pins are hard-tied to their positions due to the fact that the board layout is highly dependent on the configuration. In different configurations, the inputs and

outputs must be connected differently, making the layout for each CFG[3:0] setting unique.

The design is done on a 6-layer PCB with most power routing on the top and bottom layers. Separate analog ground (AGND) and power ground (PGND) planes are used to isolate sensitive signals from switching noise and high currents. These AGND/PGND nodes meet at the V<sub>CC</sub> input's GND connection.

When laying out a custom board, it is recommended that the power routing sections of this layout are studied thoroughly and copied as much as is relevant to the custom design. Also, be sure to follow all guidelines given in the PCB Considerations section of the LTC3376 datasheet.

### Ganging Inputs

If it is desired to power some or all inputs from the same supply, R39-R42 can be installed to tie V<sub>IN</sub> nodes to V<sub>CC</sub>. A 0Ω resistor jumper, thick wire, or solder bridge across the R39-R42 footprints is valid for this purpose. Multiple outputs can then be powered by a single supply to the V<sub>CC</sub> input, but note that the V<sub>IN</sub> range for all inputs must then be respected by the V<sub>CC</sub> input. For this board, that means the new V<sub>CC</sub> input range is 7.2V-9.8V for proper operation with R39-R42 installed.

Note that ganging inputs may increase the switching jitter.

## DEMO CIRCUIT OPERATION

### EXTV<sub>CC</sub> Input

The EXTV<sub>CC</sub> function allows for a 3V-5.5V source to be input into the EXTV<sub>CC</sub> pin to bypass an internal linear regulator that outputs 3V to EXTV<sub>CC</sub>. By using another power source such as V<sub>OUT1</sub>-V<sub>OUT4</sub>, this EXTV<sub>CC</sub> can be driven by a more efficient switching regulator output, therefore using less power.

In the JP5 = V<sub>OUT2</sub> position, V<sub>OUT2</sub> (3.3V default) is routed to EXTV<sub>CC</sub>. Note that if V<sub>OUT2</sub> is changed to a voltage that is not 3V-5.5V, this option should not be used. In the JP5 = EXT position, any valid supply can be input to the EXTV<sub>CC\_IN</sub> turret to perform this function. In the JP5 = OFF position, the internal linear regulator is used.

### SYNC Input

With JP6 = BURST/SYNC, the SYNC turret can be used to synchronize switching to an externally-generated clock. For more information, refer to the Synchronizing the Oscillator to an External Clock section of the LTC3376 datasheet.

### Sequencing

The DC2966A includes provisions to easily sequence the order of output enabling. This is achieved by making the RUN<sub>x</sub> pin voltage dependent on the level of some other voltage. On DC2966A, R3-R10 create voltage dividers with the outputs on each RUN<sub>x</sub> input. With the corre-

sponding jumper JP1-JP4 set to the OFF/SEQ position, a voltage on TP1-TP4 can enable RUN1-RUN4 at a desired input voltage, depending on the voltage divider ratio.

Figure 2 illustrates the V<sub>OUT<sub>x</sub></sub> voltages when RUN1 = ON while RUN2-RUN4 = OFF/SEQ and are driven by PGOOD1-PGOOD3 respectively. The result is that each buck is enabled when the previous buck reaches regulation.

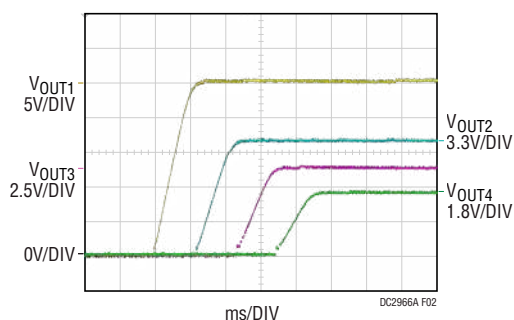

Figure 2. Sequencing V<sub>OUT1</sub>-V<sub>OUT4</sub> in Order

### PGOOD<sub>x</sub> LEDs

Each PGOOD<sub>x</sub> signal can drive an LED for a visual indication that its respective output is within a valid regulation range. If JP7 = ON, the LED power is drawn from V<sub>CC</sub> and will increase the current drawn from that input. When evaluating the low power consumption of the LTC3376, it may be helpful to set JP7 = OFF/EXT. In this position, LED power can optionally be supplied from an external 3V-20V source connected to the EXTLEDPWR turret.

## PARTS LIST

ITEM	QTY	REFERENCE	PART DESCRIPTION	MANUFACTURER/PART NUMBER
<b>Required Circuit Components</b>				
1	1	C1	CAP, 4.7uF, X5R, 25V, 20%, 0603	MURATA, GRM188R61E475ME11D
2	2	C2, C4	CAP, 4.7uF, X5R, 6.3V, 10%, 0603	KEMET, C0603C475K9PACTU
3	1	C3	CAP, 10uF, X5R, 6.3V, 10%, 0603	AVX, 06036D106KAT2A
4	4	C5-C8	CAP, 0.047uF, X7R, 25V, 10%, 0402	TDK, C1005X7R1E473K050BC
5	8	C9, C10, C17, C18, C25, C26, C33, C34	CAP, 1uF, X5R, 25V, 10%, 0402, AEC-Q200	MURATA, GRT155R61E105KE01D
6	8	C11, C12, C19, C20, C27, C28, C35, C36	CAP, 10uF, X5R, 25V, 10%, 0805	TDK, C2012X5R1E106K085AC
7	1	C13	CAP, 2.2pF, C0G, 25V, +/-0.1pF, 0402	MURATA, GRM1555C1E2R2BA01D
8	1	C14	CAP, 6.8pF, C0G/NP0, 50V, +/-0.5pF, 0402	AVX, 04025A6R8DAT2A
9	1	C15	CAP, 22uF, X5R, 16V, 10%, 0805	TDK, C2012X5R1C226K125AC

# DEMO MANUAL DC2966A

## PARTS LIST

ITEM	QTY	REFERENCE	PART DESCRIPTION	MANUFACTURER/PART NUMBER
10	2	C21, C37	CAP, 3.3PF, COG, 50V, 0.25pF, 0402	AVX, 04025A3R3CAT2A
11	1	C22	CAP, 4.7pF, COG, 50V, 0.5pF, 0402	AVX, 04025A4R7DAT2A
12	3	C23, C39, C40	CAP, 33uF, X5R, 10V, 20%, 0805	TDK, C2012X5R1A336M125AC
13	1	C29	CAP, 1.5pF, NPO, 25V, +/-0.5pF, 0402	WURTH ELEKTRONIK, 885012005035
14	1	C31	CAP, 47uF, X5R, 6.3V, 20%, 0805	TAIYO YUDEN, JMK212BBJ476MG-T
15	1	C41	CAP, 1uF, X5R, 25V, 10%, 0603	AVX, 06033D105KAT2A
16	1	C42	CAP, 0.01uF, X7R, 16V, 10%, 0402	KEMET, C0402C103K4RAC7867
17	1	C43	CAP, 10uF, X5R, 10V, 20%, 0603	AVX, 0603ZD106MAT2A
18	4	D1-D4	LED, GREEN, WATER-CLEAR, 0603, NO SUBS. ALLOWED	LITE-ON, LTST-C193KGKT-5A
19	18	E1, E2, E5-E8, E11-E14, E17-E20, E23-E26	TEST POINT, TURRET, 0.094" MTG. HOLE, PCB 0.062" THICK	MILL-MAX, 2501-2-00-80-00-00-07-0
20	10	E3, E4, E9, E10, E15, E16, E21, E22, E27, E28	CONN., BANANA JACK, FEMALE, THT, NON-INSULATED, SWAGE, 0.218"	KEYSTONE, 575-4
21	16	E29-E44	TEST POINT, TURRET, 0.064" MTG. HOLE, PCB 0.062" THICK	MILL-MAX, 2308-2-00-80-00-00-07-0
22	6	JP1-JP4, JP6, JP7	CONN., HDR, MALE, 1x3, 2mm, VERT, STR, THT, NO SUBS. ALLOWED	WURTH ELEKTRONIK, 62000311121
23	1	JP5	CONN., HDR, MALE, 1x4, 2mm, VERT, STR, THT	WURTH ELEKTRONIK, 62000411121
24	2	L1, L2	IND., 2.2uH, PWR, 20%, 9.2A, 14.5mOHMS, 5.48mmX5.28mm, XAL5030, AEC-Q200	COILCRAFT, XAL5030-222MEB
25	2	L3, L4	FIXED IND 1.5UH 6A 20 MOHM SMD	SUSUMU, PCMB053T-1R5MS
26	2	M1, M2	XSTR., MOSFET, DUAL N-CH, 0.28A, SOT-563	DIODES INC., 2N7002VAC-7
27	4	MP1-MP4	STANDOFF, NYLON, SNAP-ON, 0.625"	KEYSTONE, 8834
28	1	PCB1	PCB, DC2966A	ANALOG DEVICES, 600-DC2966A
29	2	R1, R23	RES., 0 OHM, 1/10W, 0603, AEC-Q200	VISHAY, CRCW06030000Z0EA
30	9	R2, R4, R6, R8, R10, R19-R22	RES., 5.1M OHMS, 5%, 1/16W, 0402	PANASONIC, ERJ2GEJ515X
31	4	R11-R14	RES., 4.99k OHMS, 1%, 1/16W, 0402	NIC, NRC04F4991TRF
32	4	R15-R18	RES., 200 OHMS, 1%, 1/10W, 0603	VISHAY, CRCW0603200RFKEA
33	4	R25, R28, R31, R34	RES., 20 OHMS, 1%, 1/16W, 0402, AEC-Q200	NIC, NRC04F20R0TRF
34	2	R26, R29	RES., 1.15M OHMS, 1%, 1/16W, 0402	VISHAY, CRCW04021M15FKED
35	1	R27	RES., 100k OHMS, 1%, 1/16W, 0402, AEC-Q200	VISHAY, CRCW0402100KFKED
36	1	R30	RES., 158k OHMS, 1%, 1/16W, 0402	VISHAY, CRCW0402158KFKED
37	1	R32	RES., 1.05M OHMS, 1%, 1/16W, 0402, AEC-Q200	VISHAY, CRCW04021M05FKED
38	2	R33, R36	RES., 200k OHMS, 1%, 1/16W, 0402	PANASONIC, ERJ2RKF2003X
39	1	R35	RES., 698k OHMS, 1%, 1/16W, 0402, AEC-Q200	VISHAY, CRCW0402698KFKED
40	1	R37	RES., 1.02M OHMS, 1%, 1/16W, 0402, AEC-Q200	VISHAY, CRCW04021M02FKED
41	1	R38	RES., 255k OHMS, 1%, 1/16W, 0402	VISHAY, CRCW0402255KFKED
42	1	R43	RES., 100k OHMS, 5%, 1/16W, 0402	ROHM, MCR01MZPJ104
43	1	U1	IC, 20V Monolithic Four Channel 12A Configurable Synchronous Buck DC-DC	ANALOG DEVICES, LTC3376EY#PBF
44	1	U2	IC REG LIN POS ADJ 100MA 8MSOP	ANALOG DEVICES, LT3061EMS8E#PBF
45	7	XJP1-XJP7	CONN., SHUNT, FEMALE, 2 POS, 2mm	WURTH ELEKTRONIK, 60800213421

## SCHEMATIC DIAGRAM

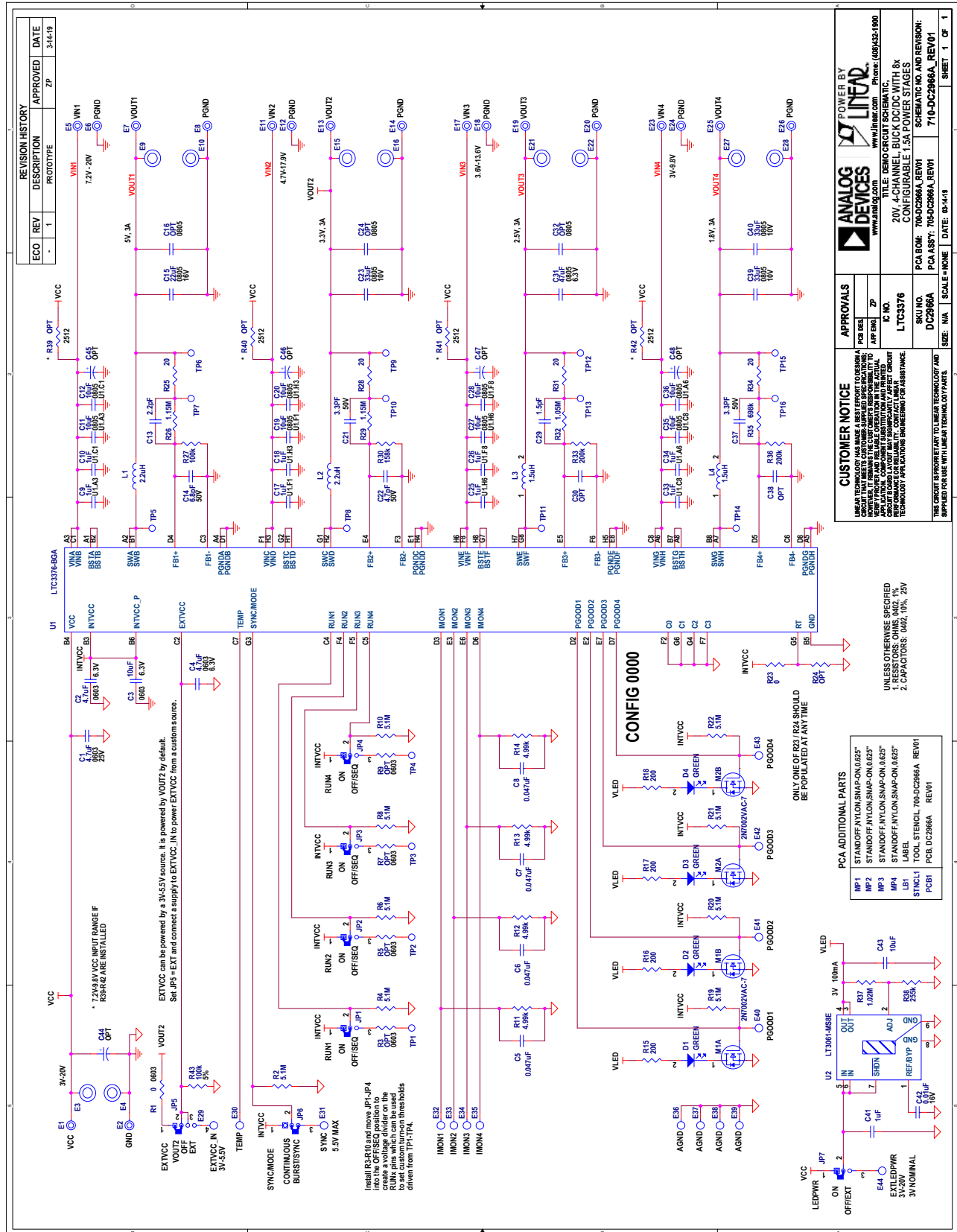



## ESD Caution

**ESD (electrostatic discharge) sensitive device.** Charged devices and circuit boards can discharge without detection. Although this product features patented or proprietary protection circuitry, damage may occur on devices subjected to high energy ESD. Therefore, proper ESD precautions should be taken to avoid performance degradation or loss of functionality.

## Legal Terms and Conditions

By using the evaluation board discussed herein (together with any tools, components documentation or support materials, the "Evaluation Board"), you are agreeing to be bound by the terms and conditions set forth below ("Agreement") unless you have purchased the Evaluation Board, in which case the Analog Devices Standard Terms and Conditions of Sale shall govern. Do not use the Evaluation Board until you have read and agreed to the Agreement. Your use of the Evaluation Board shall signify your acceptance of the Agreement. This Agreement is made by and between you ("Customer") and Analog Devices, Inc. ("ADI"), with its principal place of business at One Technology Way, Norwood, MA 02062, USA. Subject to the terms and conditions of the Agreement, ADI hereby grants to Customer a free, limited, personal, temporary, non-exclusive, non-sublicensable, non-transferable license to use the Evaluation Board FOR EVALUATION PURPOSES ONLY. Customer understands and agrees that the Evaluation Board is provided for the sole and exclusive purpose referenced above, and agrees not to use the Evaluation Board for any other purpose. Furthermore, the license granted is expressly made subject to the following additional limitations: Customer shall not (i) rent, lease, display, sell, transfer, assign, sublicense, or distribute the Evaluation Board; and (ii) permit any Third Party to access the Evaluation Board. As used herein, the term "Third Party" includes any entity other than ADI, Customer, their employees, affiliates and in-house consultants. The Evaluation Board is NOT sold to Customer; all rights not expressly granted herein, including ownership of the Evaluation Board, are reserved by ADI. CONFIDENTIALITY. This Agreement and the Evaluation Board shall all be considered the confidential and proprietary information of ADI. Customer may not disclose or transfer any portion of the Evaluation Board to any other party for any reason. Upon discontinuation of use of the Evaluation Board or termination of this Agreement, Customer agrees to promptly return the Evaluation Board to ADI. ADDITIONAL RESTRICTIONS. Customer may not disassemble, decompile or reverse engineer chips on the Evaluation Board. Customer shall inform ADI of any occurred damages or any modifications or alterations it makes to the Evaluation Board, including but not limited to soldering or any other activity that affects the material content of the Evaluation Board. Modifications to the Evaluation Board must comply with applicable law, including but not limited to the RoHS Directive. TERMINATION. ADI may terminate this Agreement at any time upon giving written notice to Customer. Customer agrees to return to ADI the Evaluation Board at that time. LIMITATION OF LIABILITY. THE EVALUATION BOARD PROVIDED HEREUNDER IS PROVIDED "AS IS" AND ADI MAKES NO WARRANTIES OR REPRESENTATIONS OF ANY KIND WITH RESPECT TO IT. ADI SPECIFICALLY DISCLAIMS ANY REPRESENTATIONS, ENDORSEMENTS, GUARANTEES, OR WARRANTIES, EXPRESS OR IMPLIED, RELATED TO THE EVALUATION BOARD INCLUDING, BUT NOT LIMITED TO, THE IMPLIED WARRANTY OF MERCHANTABILITY, TITLE, FITNESS FOR A PARTICULAR PURPOSE OR NON-INFRINGEMENT OF INTELLECTUAL PROPERTY RIGHTS. IN NO EVENT WILL ADI AND ITS LICENSORS BE LIABLE FOR ANY INCIDENTAL, SPECIAL, INDIRECT, OR CONSEQUENTIAL DAMAGES RESULTING FROM CUSTOMER'S POSSESSION OR USE OF THE EVALUATION BOARD, INCLUDING BUT NOT LIMITED TO LOST PROFITS, DELAY COSTS, LABOR COSTS OR LOSS OF GOODWILL. ADI'S TOTAL LIABILITY FROM ANY AND ALL CAUSES SHALL BE LIMITED TO THE AMOUNT OF ONE HUNDRED US DOLLARS (\$100.00). EXPORT. Customer agrees that it will not directly or indirectly export the Evaluation Board to another country, and that it will comply with all applicable United States federal laws and regulations relating to exports. GOVERNING LAW. This Agreement shall be governed by and construed in accordance with the substantive laws of the Commonwealth of Massachusetts (excluding conflict of law rules). Any legal action regarding this Agreement will be heard in the state or federal courts having jurisdiction in Suffolk County, Massachusetts, and Customer hereby submits to the personal jurisdiction and venue of such courts. The United Nations Convention on Contracts for the International Sale of Goods shall not apply to this Agreement and is expressly disclaimed.