



2.5V TO 3.3V HIGH PERFORMANCE CLOCK BUFFER

IDT5V2305

FEATURES:

- High performance 1:5 clock driver for general purpose applications
- Operates up to 170MHz at $V_{DD} = 2.5V$
- Operates up to 200MHz at $V_{DD} = 3.3V$
- Pin-to-pin skew < 75ps at 3.3V operation
- V_{DD} range: 2.3V to 3.6V
- Output enable glitch suppression
- Available in TSSOP and VFQFPN packages

NOTE: EOL for non-green parts to occur on 5/13/10 per PDN U-09-01

DESCRIPTION:

The IDT5V2305 is a high performance, low skew clock buffer that operates up to 200MHz. One bank of five outputs provides low skew copies of CLK. Through the use of control pin G, the outputs of bank Y(0:4) can be placed in a low state regardless of CLK input. The device operates in 2.5V and 3.3V environments. The built-in output enable glitch suppression ensures a synchronized output enable sequence to distribute full period clock signals.

The IDT5V2305 is characterized for operation from -40°C to +85°C.

FUNCTIONAL BLOCK DIAGRAM

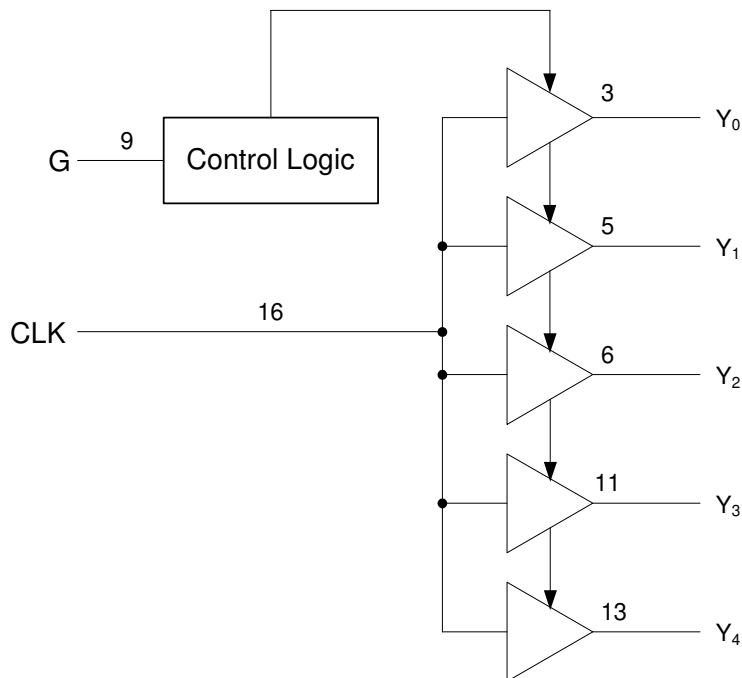

PIN CONFIGURATION

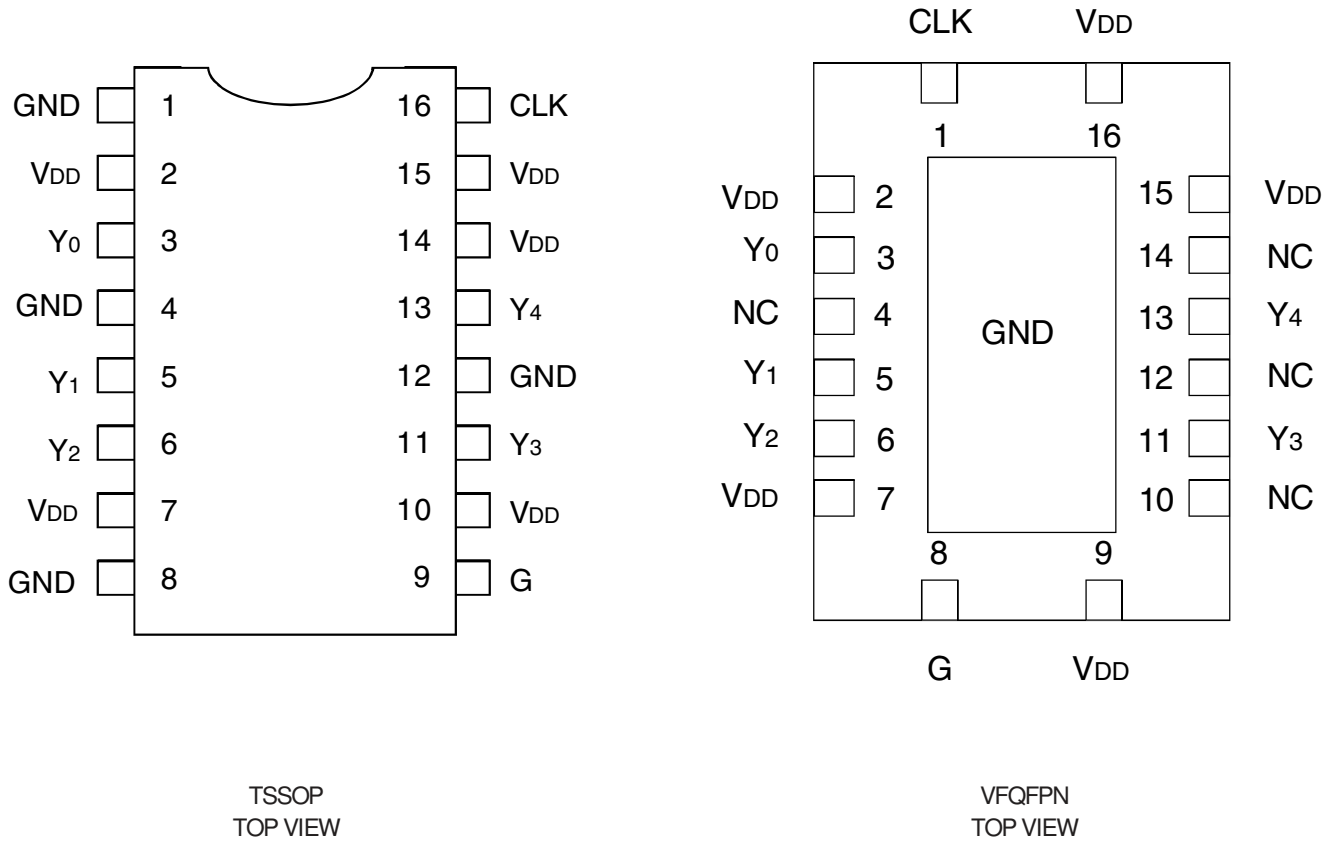

ABSOLUTE MAXIMUM RATINGS⁽¹⁾

Symbol	Description	Max	Unit
V _{DD}	Power Supply Voltage	-0.5 to +4.6	V
V _I	Input Voltage ⁽²⁾	-0.5 to V _{DD} +0.5	V
V _O	Output Voltage ⁽²⁾	-0.5 to V _{DD} +0.5	V
I _{IK}	Input Clamp Current V _I < 0 or V _I > V _{DD}	±50	mA
I _{OK}	Output Clamp Current V _O < 0 or V _O > V _{DD}	±50	mA
I _O	Continuous Total Output Current V _O < 0 to V _{DD}	±50	mA
T _{STG}	Storage Temperature	-65 to +150	°C

NOTES:

- Stresses greater than those listed under ABSOLUTE MAXIMUM RATINGS may cause permanent damage to the device. This is a stress rating only and functional operation of the device at these or any other conditions above those indicated in the operational sections of this specification is not implied. Exposure to absolute maximum rating conditions for extended periods may affect reliability.
- Not to exceed 4.6V.

CAPACITANCE⁽¹⁾ (T_A = +25°C, f = 1MHz, V_{IN} = 0V)

Parameter	Description	Min.	Typ.	Max.	Unit
C _{IN}	Input Capacitance V _I = 0V or V _{DD}	—	2.5	—	pF

FUNCTION TABLE⁽¹⁾

Inputs		Output
G	CLK	Y(0:4)
L	X	L
H	H	H

NOTE:

- H = HIGH Voltage Level
L = LOW Voltage Level
X = Don't Care

PIN DESCRIPTION

TERMINAL		Description
Symbol	I/O	
G	I	Output Enable Control for Y _(0:4) Outputs. This output enable is active HIGH. If this pin is Logic HIGH, the Y _(0:4) clock outputs will follow the input clock (CLK). If this pin is logic LOW, the Y _(0:4) outputs will drive low independent of the state of CLK.
Y _(0:4)	O	Buffered Output Clocks
CLK	I	Input Reference Frequency
GND		Ground
V _{DD}	PWR	DC Power Supply, 2.3V to 3.6V

RECOMMENDED OPERATING RANGE

Symbol	Description	Min.	Typ.	Max.	Unit
V _{DD}	Internal Power Supply Voltage	2.3	2.5		V
			3.3	3.6	
V _{IL}	Input Voltage LOW	V _{DD} = 3V to 3.6V		0.8	V
		V _{DD} = 2.3V to 2.7V		0.7	
V _{IH}	Input Voltage HIGH	V _{DD} = 3V to 3.6V	2		V
		V _{DD} = 2.3V to 2.7V	1.7		
V _I	Input Voltage	0		V _{DD}	V
I _{OH}	Output Current HIGH	V _{DD} = 3V to 3.6V		-12	mA
		V _{DD} = 2.3V to 2.7V		-6	
I _{OL}	Output Current LOW	V _{DD} = 3V to 3.6V		12	mA
		V _{DD} = 2.3V to 2.7V		6	
T _A	Ambient Operating Temperature	-40		+85	°C

DC ELECTRICAL CHARACTERISTICS OVER OPERATING RANGE

Symbol	Parameter	Test Conditions	Min.	Typ.	Max	Unit
V _{IK}	Input Voltage	V _{DD} = 3V, I _{IN} = -18mA			-1.2	V
I _{IN}	Input Current	V _I = 0V or V _{DD}			±5	μA
I _{DD}	Static Device Current ⁽¹⁾	CLK = 0V or V _{DD} , I _O = 0mA, V _{DD} = 3.3V			25	μA

NOTE:

1. For I_{DD} over frequency, see TEST CIRCUIT AND WAVEFORMS.

DC ELECTRICAL CHARACTERISTICS - V_{DD} = 3.3V ± 0.3V

Symbol	Parameter	Test Conditions		Min.	Typ. ⁽¹⁾	Max	Unit
V _{OH}	HIGH level Output Voltage	V _{DD} = Min. to Max.	I _{OH} = -100μA	V _{DD} - 0.2			V
		V _{DD} = 3V	I _{OH} = -12mA	2.1			
			I _{OH} = -6mA	2.4			
V _{OL}	LOW level Output Voltage	V _{DD} = Min. to Max.	I _{OH} = 100μA			0.2	V
		V _{DD} = 3V	I _{OH} = 12mA			0.8	
			I _{OH} = 6mA			0.55	
I _{OH}	HIGH level Output Current	V _{DD} = 3V	V _O = 1V	-28			mA
		V _{DD} = 3.3V	V _O = 1.65V		-36		
		V _{DD} = 3.6V	V _O = 3.135V			-14	
I _{OL}	LOW level Output Current	V _{DD} = 3V	V _O = 1.95V	28			mA
		V _{DD} = 3.3V	V _O = 1.65V		36		
		V _{DD} = 3.6V	V _O = 0.4V			14	

NOTE:

1. All typical values are at respective nominal V_{DD}.

DC ELECTRICAL CHARACTERISTICS - $V_{DD} = 2.5V \pm 0.2V$

Symbol	Parameter	Test Conditions		Min.	Typ. ⁽¹⁾	Max	Unit
V _{OH}	HIGH level Output Voltage	V _{DD} = Min. to Max.	I _{OH} = -100μA	V _{DD} - 0.2			V
		V _{DD} = 2.3V	I _{OH} = -6mA	1.8			
V _{OL}	LOW level Output Voltage	V _{DD} = Min. to Max.	I _{OH} = 100μA			0.2	V
		V _{DD} = 2.3V	I _{OH} = 6mA			0.55	
I _{OH}	HIGH level Output Current	V _{DD} = 2.3V	V _O = 1V	-17			mA
		V _{DD} = 2.5V	V _O = 1.25V		-25		
		V _{DD} = 2.7V	V _O = 2.375V			-10	
I _{OL}	LOW level Output Current	V _{DD} = 2.3V	V _O = 1.2V	17			mA
		V _{DD} = 2.5V	V _O = 1.25V		25		
		V _{DD} = 2.7V	V _O = 0.3V			10	

NOTE:

1. All typical values are at respective nominal V_{DD}.

TIMING REQUIREMENTS OVER RECOMMENDED RANGE

Symbol	Parameter	Test Conditions	Min.	Typ.	Max	Unit
f _{CLK}	Clock Frequency	V _{DD} = 3V to 3.6V	0		200	MHz
		V _{DD} = 2.3V to 2.7V	0		170	

SWITCHING CHARACTERISTICS OVER OPERATING RANGE -

$$V_{DD} = 3.3V \pm 0.3V^{(1)}$$

Symbol	Parameter	Test Conditions	Min.	Typ. ⁽¹⁾	Max	Unit
t _{PLH} t _{PHL}	CLK to Yx	f = 0MHz to 200MHz, C _L = 25pF	1.3		2.6	ns
tsk(o) ⁽²⁾	Output Skew, Yx to Yx				75	ps
tsk(p)	Pulse Skew				200	ps
tsk(pp)	Part-to-Part Skew				500	ps
t _R	Rise Time	V _O = 0.4V to 2V ⁽³⁾	0.7		2.3	V/ns
t _F	Fall Time	V _O = 2V to 0.4V ⁽³⁾	0.7		2.3	V/ns
tsu	G before CLK↓	V _(THRESHOLD) = V _{DD} /2	0.1			ns
t _H	G after CLK↓		0.4			

NOTES:

1. All typical values are at respective nominal V_{DD}.
2. This specification is only valid for equal loading of all outputs.
3. Measured at 100MHz.

SWITCHING CHARACTERISTICS OVER OPERATING RANGE -

$$V_{DD} = 2.5V \pm 0.2V^{(1)}$$

Symbol	Parameter	Test Conditions	Min.	Typ. ⁽¹⁾	Max	Unit
t _{PLH} t _{PHL}	CLK to Yx	f = 0MHz to 170MHz, C _L = 25pF	1.5		3	ns
tsk(o) ⁽²⁾	Output Skew, Yx to Yx				100	ps
tsk(p)	Pulse Skew				350	ps
tsk(pp)	Part-to-Part Skew				600	ps
t _R	Rise Time	V _O = 0.4V to 1.7V ⁽³⁾	0.4		1.625	V/ns
t _F	Fall Time	V _O = 1.7V to 0.4V ⁽³⁾	0.4		1.625	V/ns
tsu	G before CLK↓	V _(THRESHOLD) = V _{DD} /2	0.1			ns
t _H	G after CLK↓		0.4			

NOTES:

1. All typical values are at respective nominal V_{DD}.
2. This specification is only valid for equal loading of all outputs.
3. Measured at 100MHz.

OUTPUT ENABLE GLITCH SUPPRESSION CIRCUIT

The purpose of the glitch suppression circuitry is to ensure the output enable sequence is synchronized with the clock input such that the output buffer will be enabled on the next full period of the input clock (negative edge triggered by the input clock). The G input must be stable one t_{EN} - time prior to the falling edge of the CLK for predictable operation.

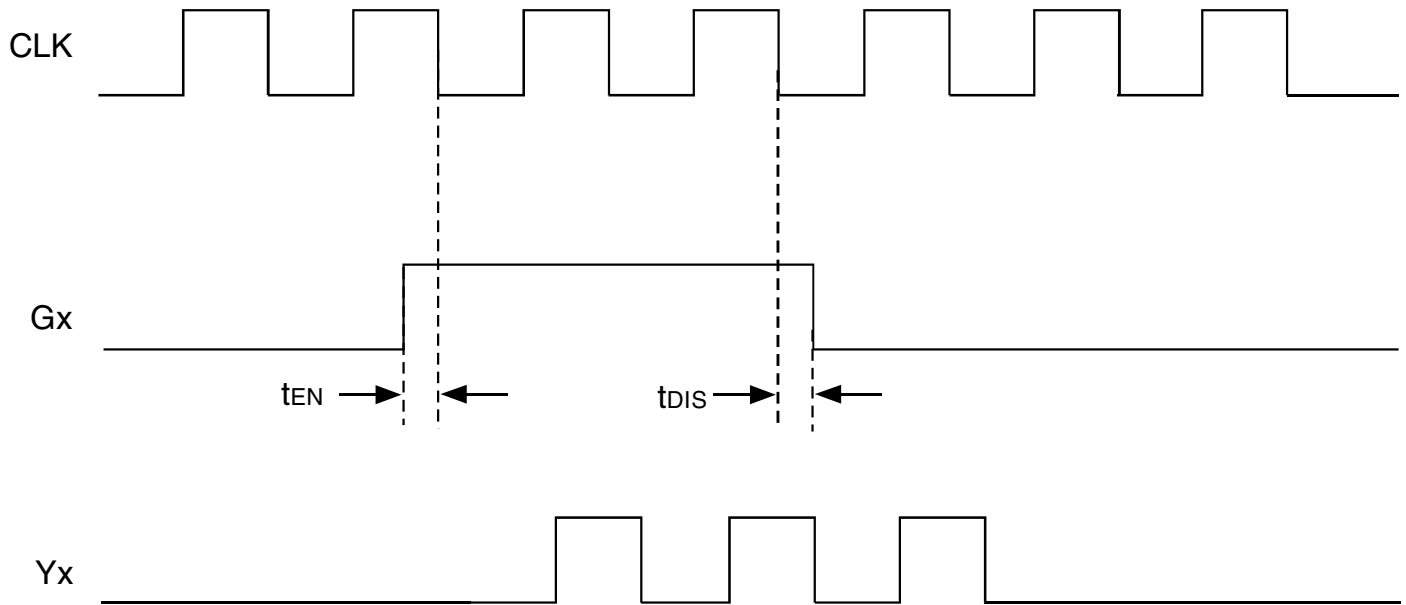

G (t_{EN} , t_{DIS}) Relative to CLK↓

TEST CIRCUITS AND WAVEFORMS

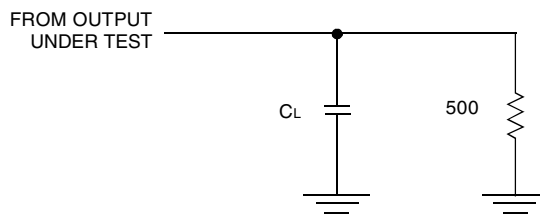

NOTES:

1. CL includes probe and jig capacitance.
2. All input pulses are supplied by generators having the following characteristics:
PRR \leq 200MHz; $Z_o = 50\Omega$; $t_R < 1.2ns$; $t_F < 1.2ns$.

Test Load Circuit

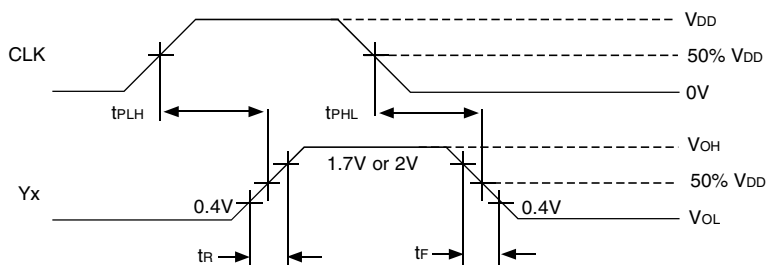

Voltage Waveforms Propagation Delay Times

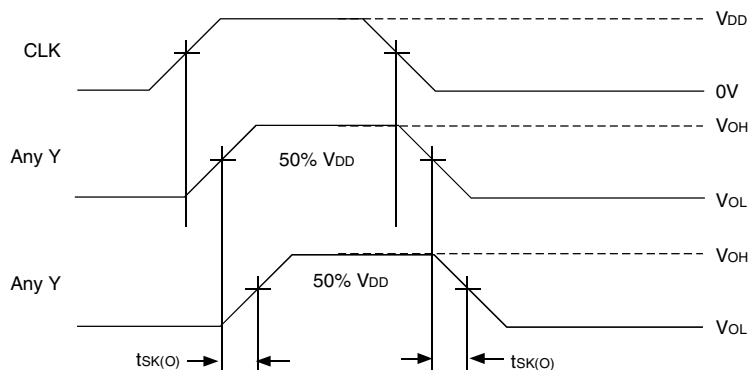

Output Skew

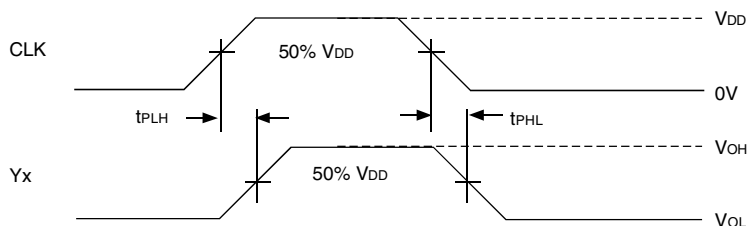

$$t_{sk(P)} = |t_{PLH} - t_{PHL}|$$

Pulse Skew

TEST CIRCUITS AND WAVEFORMS (cont.)

I_{dd} vs Frequency

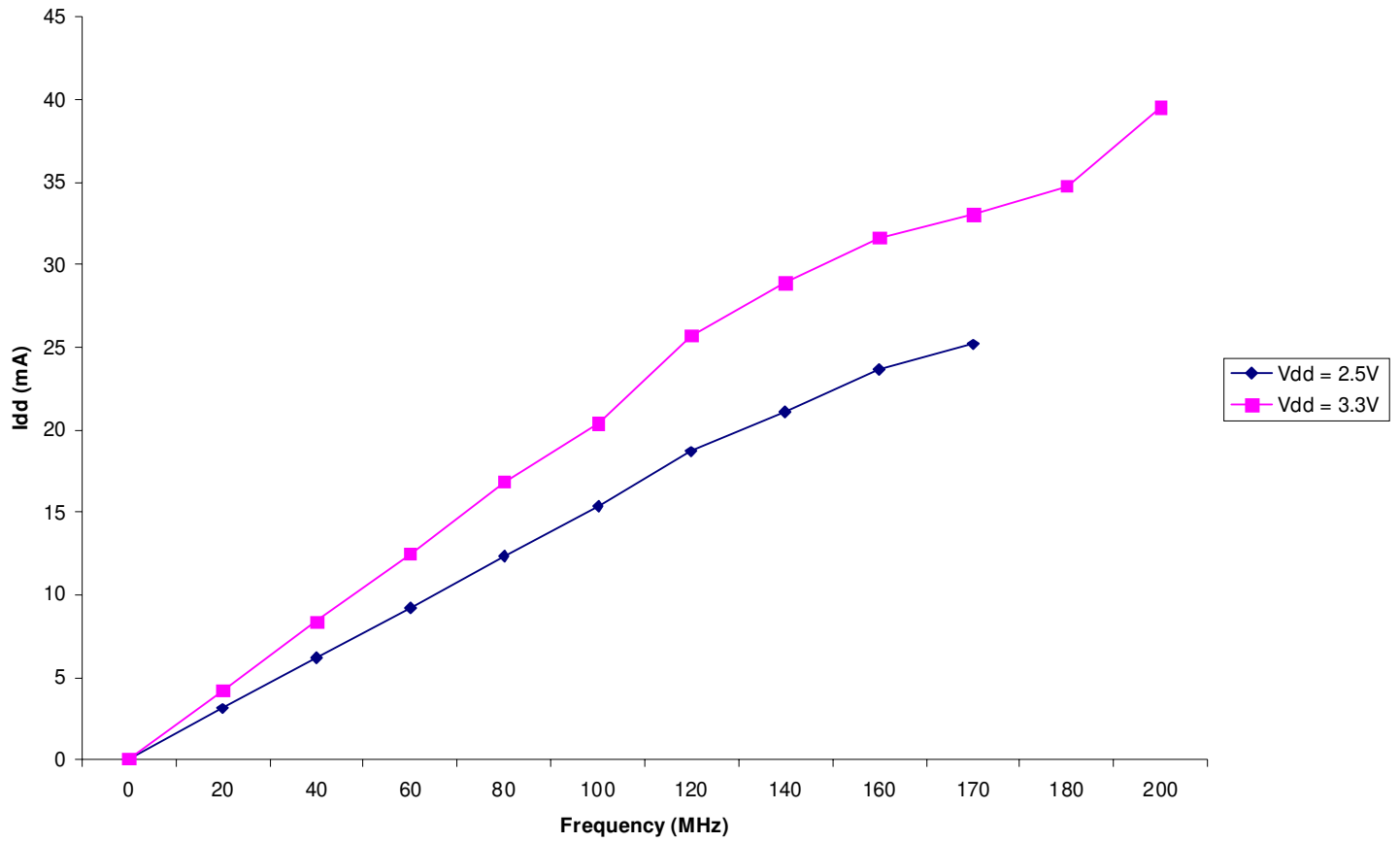

RECOMMENDED LANDING PATTERN

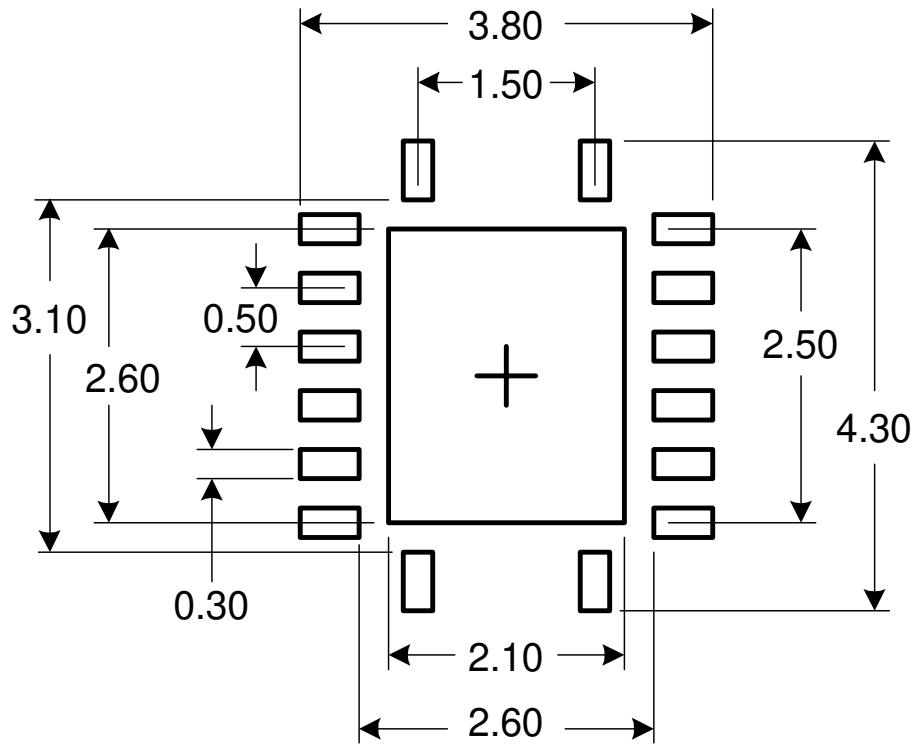

NR 16 pin

NOTE: All dimensions are in millimeters.

ORDERING INFORMATION

Part / Order Number	Shipping Packaging	Package	Temperature
5V2305PGI	Tubes	16-pin TSSOP	-40 to +85° C
5V2305PGI8	Tape and Reel	16-pin TSSOP	-40 to +85° C
5V2305PGGI	Tubes	16-pin TSSOP	-40 to +85° C
5V2305PGGI8	Tape and Reel	16-pin TSSOP	-40 to +85° C
5V2305NRI	Tubes	16-pin VFQFPN	-40 to +85° C
5V2305NRI8	Tape and Reel	16-pin VFQFPN	-40 to +85° C
5V2305NRGI	Tubes	16-pin VFQFPN	-40 to +85° C
5V2305NRGI8	Tape and Reel	16-pin VFQFPN	-40 to +85° C

"G" suffix to the part number are the Pb-Free configuration and are RoHS compliant.

NOTE: EOL for non-green parts to occur on 5/13/10 per PDN U-09-01



CORPORATE HEADQUARTERS
6024 Silver Creek Valley Road
San Jose, CA 95138

for SALES:
800-345-7015 or 408-284-8200
fax: 408-284-2775
www.idt.com

for Tech Support:
clockhelp@idt.com