

THIS DRAWING IS UNPUBLISHED. RELEASED FOR PUBLICATION
 © COPYRIGHT - By - ALL RIGHTS RESERVED.

LOC	DIST	REVISIONS					
		P	LTR	DESCRIPTION	DATE	DWN	APVD
AF	50	B4		REVISED PER ECR-11-017500	29AUG11	HMR	GJ

- SPECIFICATIONS:
MAGNET WIRE #18 - #34 AWG,
1.02mm(.040")-0.16mm(.006") DIA COPPER.
- POCKET RECOMMENDATION: NUMBER 1601425. ALTERNATE
POCKET NUMBER 1601421.
- TERMINAL TO BE APPLIED PER TYCO ELECTRONICS
SPECIFICATION 114-13166 FIGURE 6.
- TWO(2) TERMINALS SHOWN FOR ILLUSTRATION PURPOSES ONLY

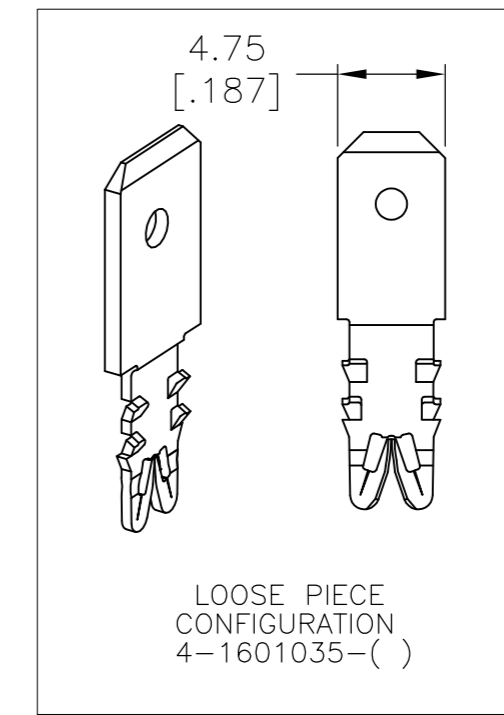
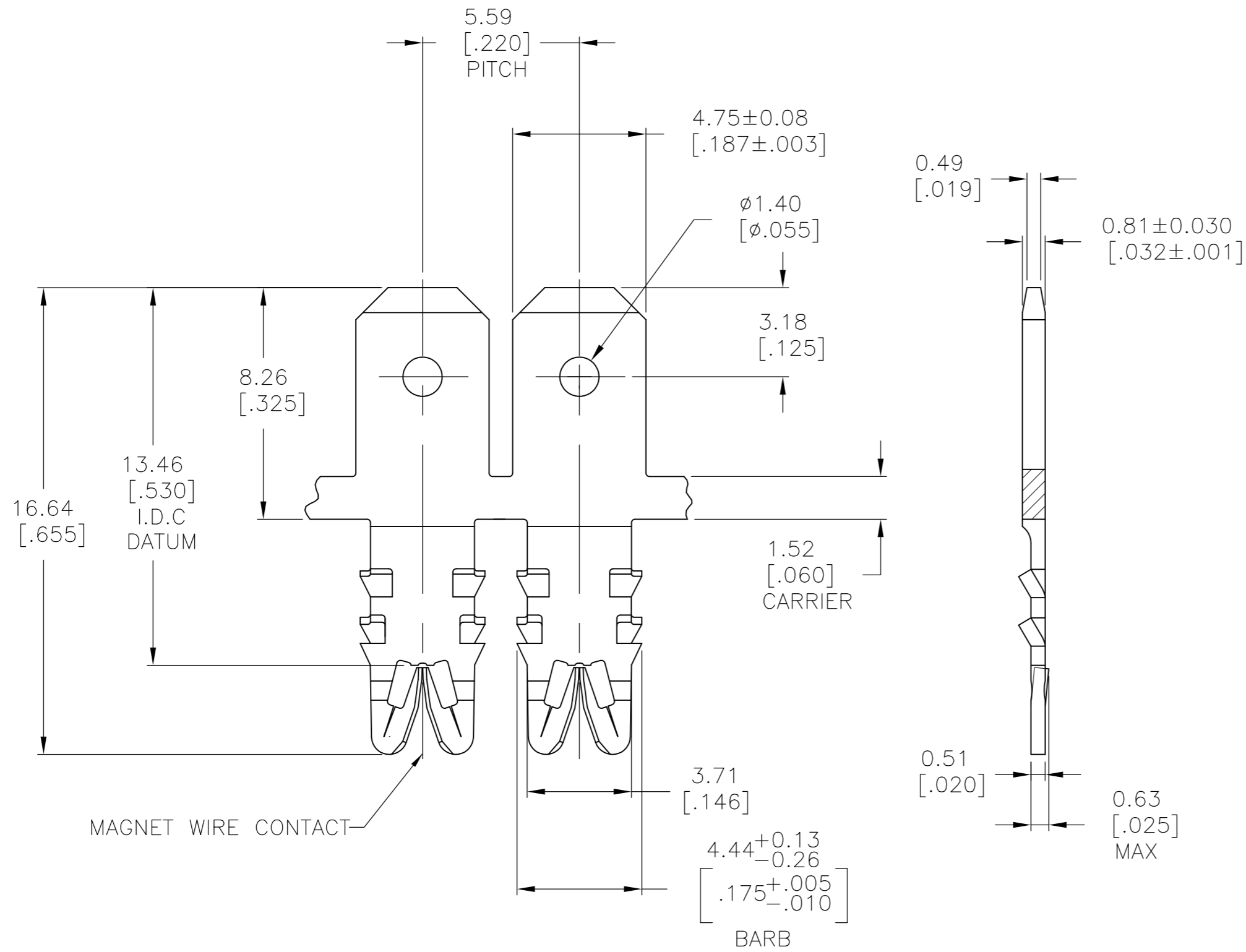

POST TIN PLATED	031-081-002	4-1601035-2
UNPLATED	031-081-000	4-1601035-1
POST TIN PLATED	131-081-002	2-1601035-2
OBSOLETE UNPLATED	131-081-000	2-1601035-1
POST TIN PLATED	--	1601035-2
UNPLATED	131-082-000	1601035-1
FINISH	REFERENCE PART NUMBER	TE PART NUMBER
THIS DRAWING IS A CONTROLLED DOCUMENT.		DWN J.WELLER 11JAN2002
DIMENSIONS: mm [INCHES]		CHK M.FEHER 11JAN2002
TOLERANCES UNLESS OTHERWISE SPECIFIED:		APVD K.RANDOLPH 11JAN2002
0 PLC ± -	1 PLC ± 0.25[.01]	NAME
2 PLC ± 0.13[.005]	3 PLC ± -	PRODUCT SPEC
4 PLC ± -	ANGLES ± 2°	108-2085
MATERIAL BRASS, 1/2 HARD	FINISH SEE TABLE	APPLICATION SPEC
WEIGHT -		SIZE A2
CUSTOMER DRAWING		CAGE CODE 00779
SCALE 6:1		DRAWING NO C=1601035
SHEET 1 OF 1		RESTRICTED TO -
REV B4		