

SPECIFICATION

Part No. : **CAB.916**

Product Name : Taoglas Cable Assembly
N type Male Straight to
N type Male Straight
with 1M CFD-200 cable

Photo :



1. Cable Insertion Loss

CAB.916

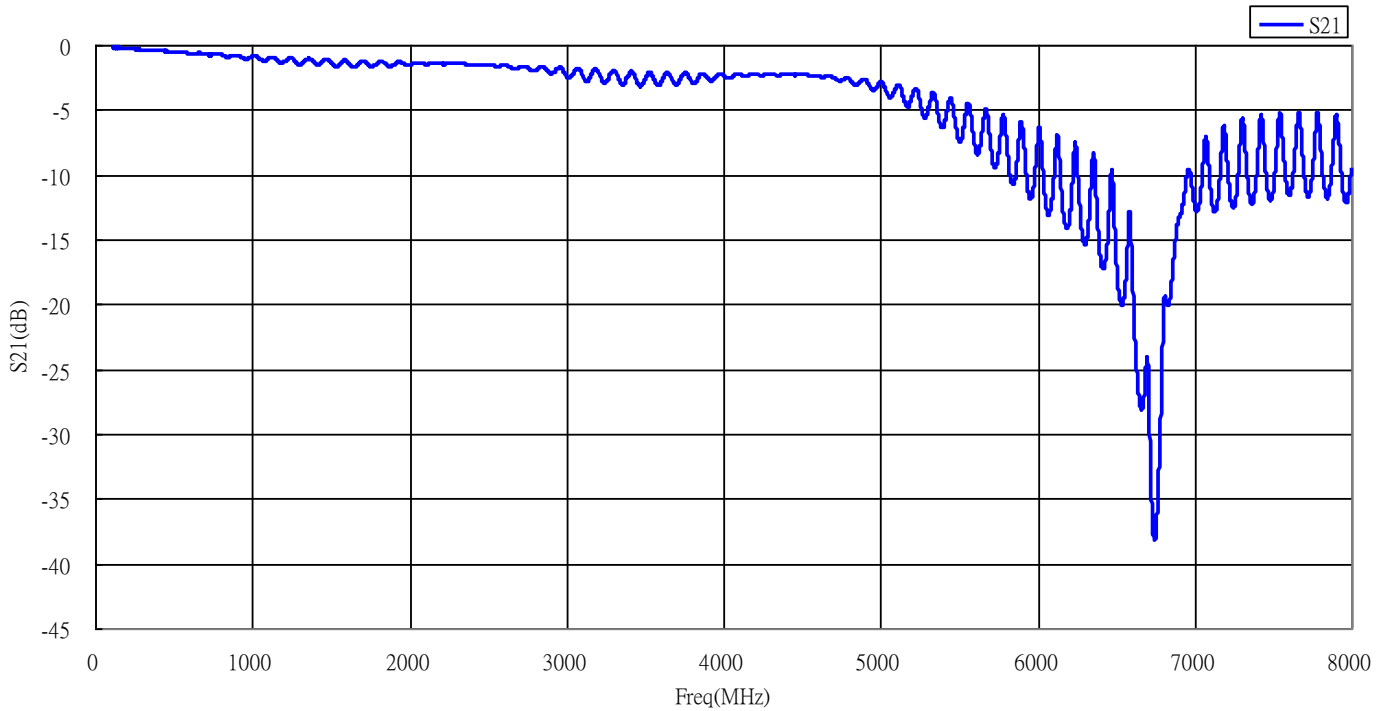

2. CFD-200 Cable Specification

2.1 Drawing – Cross Section

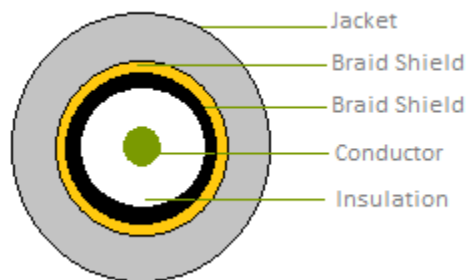

2.2 Structure and Dimensions

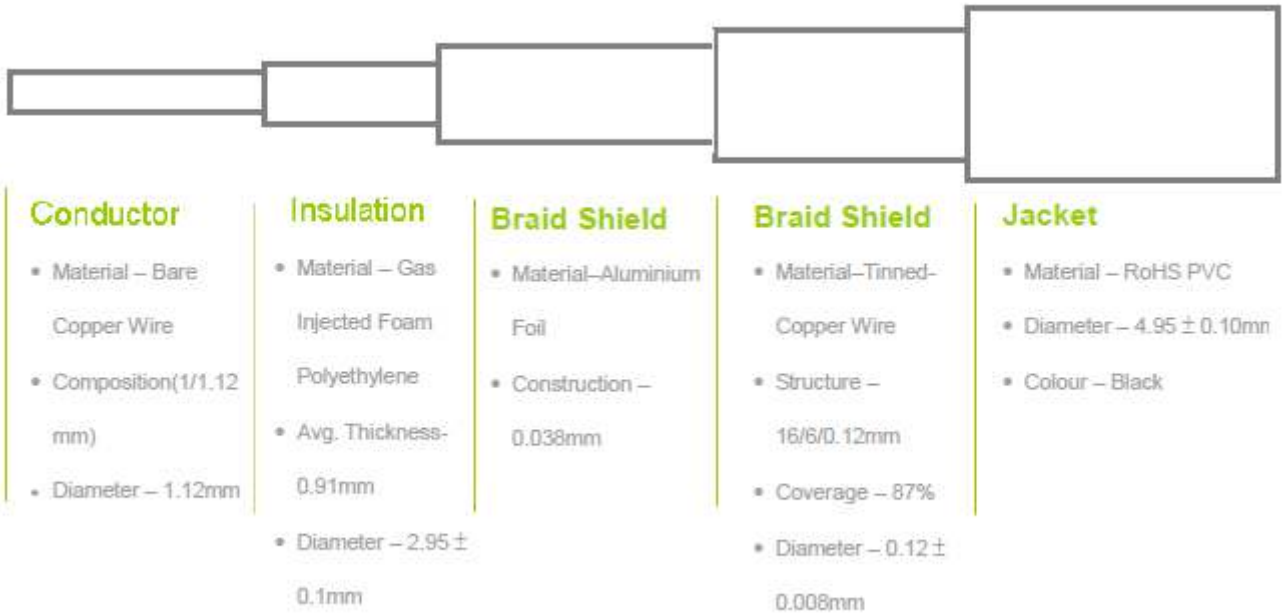

2.3 Electrical & Physical Specification

Insulation Resistance:	1000 MΩ-Km (Min)					
Capacitance	80.4 ± 3 pF/m					
Nom. Impedance	50 ± 3 Ω					
Attenuation (dB/100M)	150MHZ	450MHZ	900MHZ	1500MHZ	1800MHZ	2500MHZ
	12.1	21.6	31.2	41.1	45.3	54.4

3. Technical Drawing

3.1 CAB.916

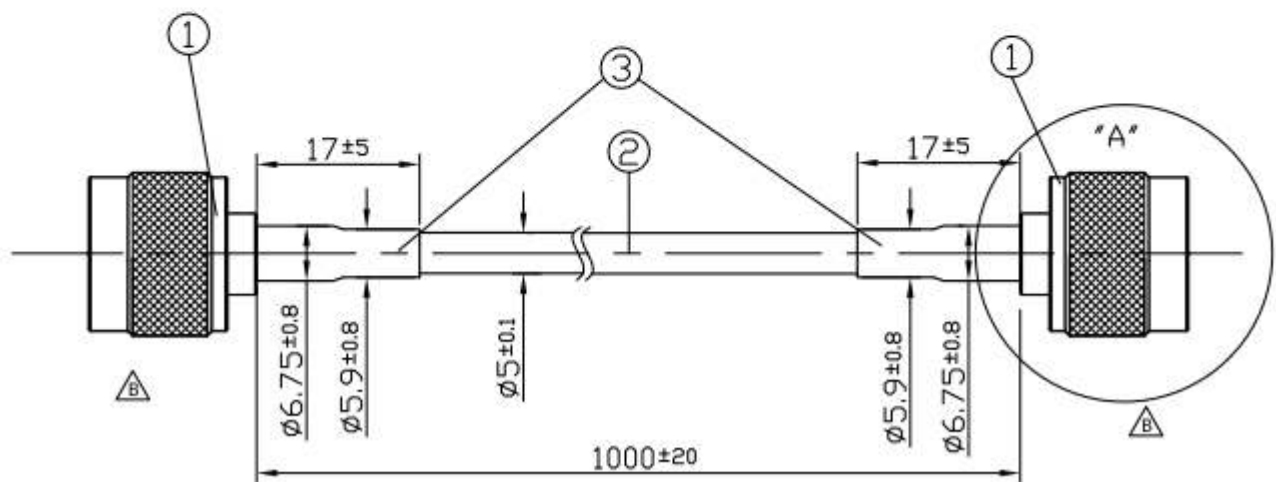
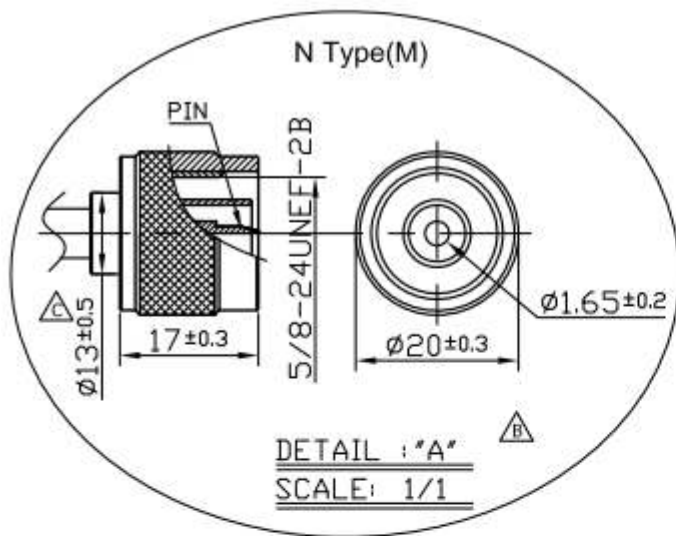

	Name	Part No.	Material	Finish	QTY
1	N Type(M)	N.TYPE.M.ST.PLUG.CFD200.J	Brass	Ni Plated	2
2	CFD-200	CFD.200.J	PVC Jacket	Black	1
3	Heat Shrink Tube	001311F0100XXA	PE	Black	2

3.2 Connector

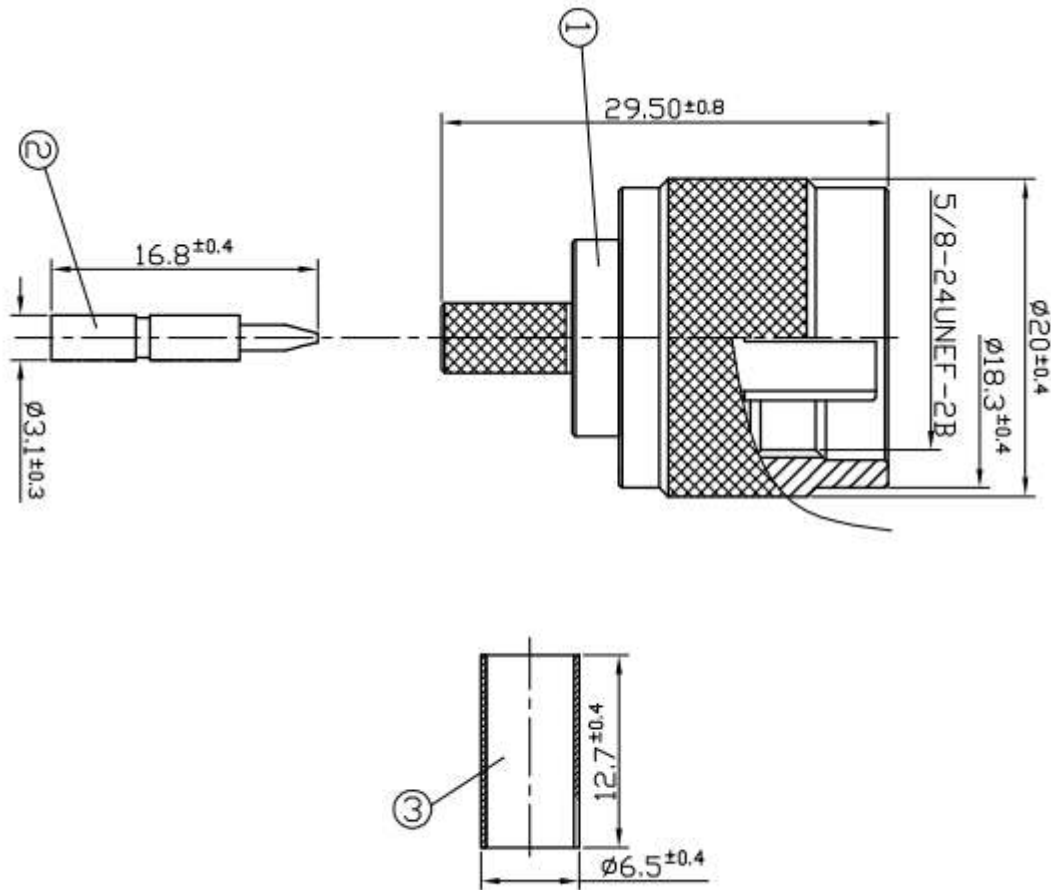

	Name	Material	Finish	QTY
1	Body	Brass	Nickel	1
2	PIN	Brass	Gold Plated	1
3	Ferrule	Brass	Nickel	1