

SIEMENS

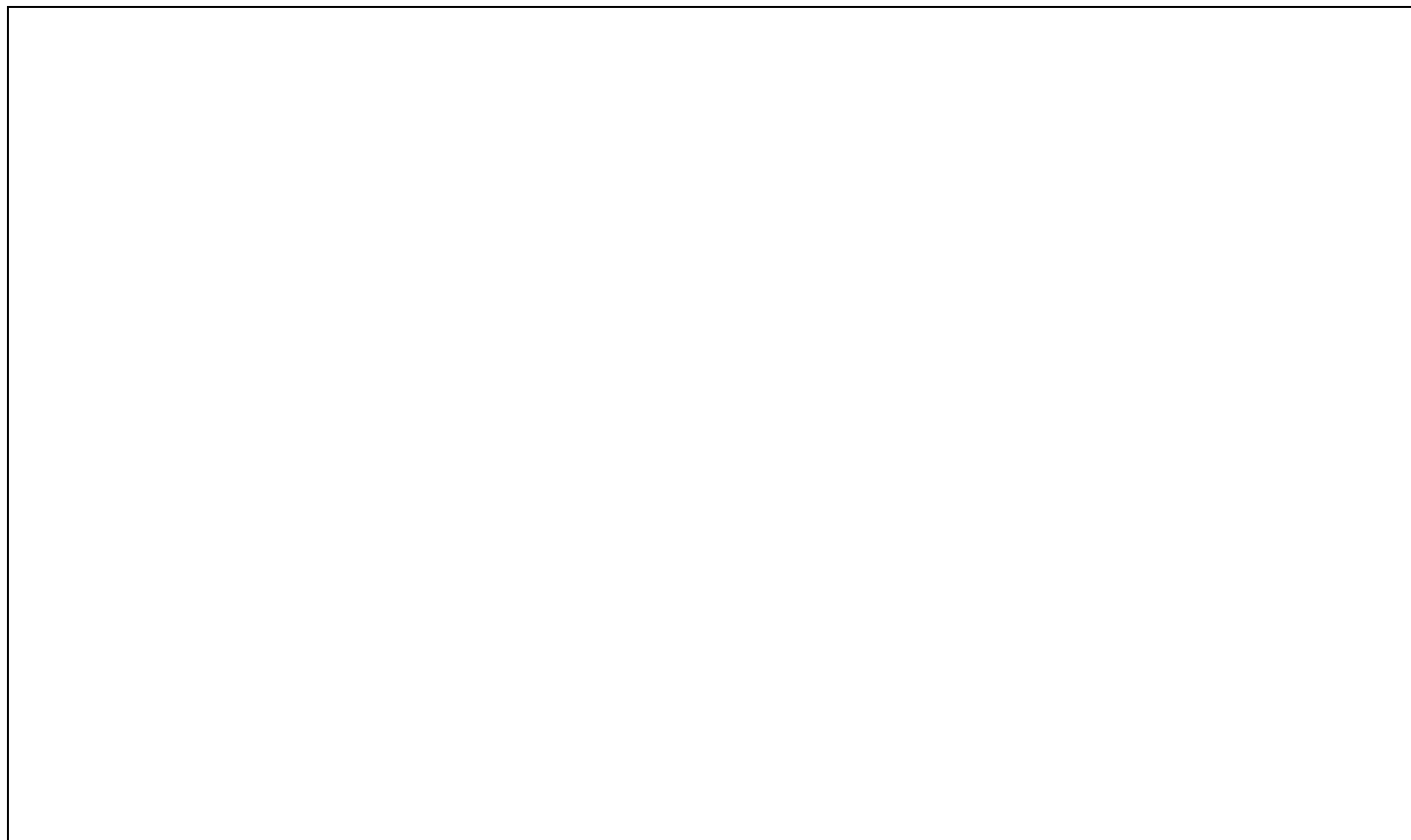

ICs for Communications

Signal Processing Subscriber Line Interface Codec Filter
SLICOFI[®]

PEB 3065 Version 3.2

PEF 3065 Version 3.2

Data Sheet 01.98

DS 2

PEB 3065		
PEF 3065		
Revision History:		Current Version: 01.98
Previous Version:		03.95 (V 1.0)
Page (in previous Version)	Page (in current Version)	Subjects (major changes since last revision)

Edition 01.98

**Published by Siemens AG,
HL TS,
Balanstraße 73,
81541 München**

**© Siemens AG 1997.
All Rights Reserved.**

Attention please!

As far as patents or other rights of third parties are concerned, liability is only assumed for components, not for applications, processes and circuits implemented within components or assemblies.

The information describes the type of component and shall not be considered as assured characteristics.

Terms of delivery and rights to change design reserved.

For questions on technology, delivery and prices please contact the Semiconductor Group Offices in Germany or the Siemens Companies and Representatives worldwide (see address list).

Due to technical requirements components may contain dangerous substances. For information on the types in question please contact your nearest Siemens Office, Semiconductor Group.

Siemens AG is an approved CECC manufacturer.

Packing

Please use the recycling operators known to you. We can also help you – get in touch with your nearest sales office. By agreement we will take packing material back, if it is sorted. You must bear the costs of transport.

For packing material that is returned to us unsorted or which we are not obliged to accept, we shall have to invoice you for any costs incurred.

Components used in life-support devices or systems must be expressly authorized for such purpose!

Critical components¹ of the Semiconductor Group of Siemens AG, may only be used in life-support devices or systems² with the express written approval of the Semiconductor Group of Siemens AG.

- 1 A critical component is a component used in a life-support device or system whose failure can reasonably be expected to cause the failure of that life-support device or system, or to affect its safety or effectiveness of that device or system.
- 2 Life support devices or systems are intended (a) to be implanted in the human body, or (b) to support and/or maintain and sustain human life. If they fail, it is reasonable to assume that the health of the user may be endangered.

Table of Contents		Page
1	General Description	5
1.1	Features	6
2	Pin Configuration	8
2.1	Pin Definition and Functions	9
3	SLICOFI[®] Principles	12
3.1	SLICOFI [®] Signal Flow Graph: AC	12
3.2	SLICOFI [®] Signal Flow Graph: DC	13
3.3	Test Features	14
3.4	SLICOFI [®] Signal Block Diagram	15
4	IOM[®]-2 Interface	16
5	Programming the SLICOFI[®]	19
5.1	Types of Monitor Bytes	19
5.2	SLICOFI [®] Programming Procedure	20
5.3	SOP Command	25
5.4	TOP Command	36
5.5	COP Command	41
5.6	IOM [®] -2 Interface Command / Indication Byte	42
6	Operating Modes	45
6.1	Reset Behavior	47
6.2	Basic Setting Modes	47
6.3	Power Denial (PDen)	49
6.4	Power Down (PDown)	49
6.5	Active Mode (Act)	50
6.6	Ringling Mode	51
7	SLIC Interface	53
8	Transmission Characteristics	55
8.1	Frequency Response	57
8.2	Group Delay	58
8.3	Out-of-Band Signals at Analog Output (receive)	59
8.4	Out-of-Band Signals at Analog Input (transmit)	60
8.5	Overload Compression	61
8.6	Gain Tracking (receive or transmit)	62
8.7	Total Distortion	63
8.8	Transhybrid Loss	65
9	Electrical Characteristics	66
9.1	Absolute Maximum Ratings	66
9.1.1	Operating Range	67
9.2	Digital Interface	68

Table of Contents		Page
9.3	DC-Feeding	70
9.3.1	DC-Feeding ($T_A = 0$ to 70 °C)	70
9.3.2	DC-Feeding ($T_A = -40$ to 85 °C)	70
9.4	HV-SLIC Interface	71
9.5	IOM [®] -2 Interface Timing	72
9.6	IOM [®] -2 Command/Indication Interface Timing (DCL = 4096 kHz)	74
9.7	IOM [®] -2 Command/Indication Interface Timing (DCL = 2048 kHz)	75
9.8	External Masterclock	76
10	Appendix	77
10.1	IOM [®] -2 Interface Monitor Transfer Protocol	77
10.2	Channel Identification Command (CIC)	81
10.3	Test Modes	85
10.4	List of Abbreviations	98
11	Package Outlines	102

1 General Description

The Signal Processing Subscriber Line Interface Codec Filter SLICOFI (PEB 3065/PEF 3065) is a logic continuation of the well established family of the SIEMENS PCM-Codec-Filter-IC's with the vertical integration of all DC-feeding, Supervision and Meterpulse Injection features on chip as well. Fabricated in a standard 1 μm BiCMOS technology the SLICOFI is tailored for very flexible solutions in digital communication systems.

For the first time the SLICOFI uses the benefits of a DSP not only for the voice channel but even for line feeding and supervision which leads to a very high flexibility without the need for external components.

Based on an advanced digital filter concept, the PEB 3065/PEF 3065 provides excellent transmission performance. The new filter concept (second generation in SIEMENS-Codec-family) leads to a maximum of independence between the different filter blocks. Each filter block can be seen as a one to one representative of the corresponding network element. Together with the software package SLICOS, filter optimizing to different applications can be done in a clear and straight forward procedure. The AC frequency behavior is mainly determined by the digital filters. Using the new oversampling 1 bit-AD/DA converter, linearity is only limited by second order parasitic effects.

The new - digital - solution of line feeding offers free programmability of feeding current and voltage as well as very fast settling of the dc-operating point after transitions. A 0.3 Hz lowpass filter in the DC-loop is mainly responsible for the system stability.

Additionally teletax generation and filtering is implemented as well as free programmable (balanced) ring generation with zero-crossing injection. Offhook detection with programmable thresholds is possible in all operating modes. To reduce overall power consumption of the line card, the SLICOFI provides a special mode called Power Denial where Offhook is done via 2 high voltage inputs (V_{LINE1} and V_{LINE2}) directly connected to the line if the HV-SLIC is switched off.

Signal Processing
Subscriber Line Interface Codec Filter
SLICOFI®

PEB 3065
PEF 3065

Data Sheet for the Version 3.2

CMOS

1.1 Features

- Single chip CODEC and FILTER including all LOW VOLTAGE SLIC functions
- Only few external components required
- No trimming or adjustments required
- Specification according to relevant CCITT, LSSGR and DBP recommendations
- Digital signal processing technique
- Advanced low power 1 μm BiCMOS¹⁾ technology
- PCM encoded digital voice transmission (A-Law or μ -Law)
- Four pin serial IOM-2 Interface
- Standard P-LCC-44 package
- High performance AD and DA Conversion
- Programmable digital filters for
 - Impedance matching
 - Transhybrid balancing
 - Frequency response
 - Gain
- Advanced test capabilities
 - Integrated line and circuit tests
 - Two programmable tone generators
- Optimized HV-SLIC Interface
- Fully digital programmable DC-Characteristic
 - Programmable Constant Current from 0-70 mA
 - Programmable Resistive Values from 0-2 \times 500 Ω
- Programmable Integrated Teletax Injection and Filtering during Conversation and Onhook
 - Programmable up to 125 mVrms (5 Vrms at ab-wire)
 - Programmable frequency 12/16 kHz

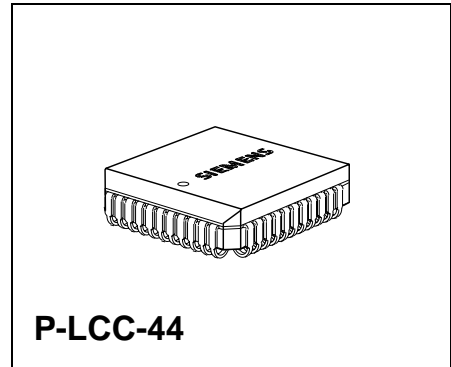

¹⁾ Abbreviations see **chapter 10.4.**

Type	Package
PEB 3065N V3.2	P-LCC-44 / Tube
PEB 3065N V3.2	P-LCC-44 / Tape in Real
PEF 3065N V3.2	P-LCC-44 / Tape in Real

General Description

- Polarity reversal (programmable soft or hard)
- Integrated (balanced) Ringing Generation with zero crossing injection
 - Programmable frequency between 16.6 and 70 Hz (up to 300 Hz for test)
 - Programmable amplitude up to 2.125 Vrms (85 Vrms at ab-wire)
- Four operating modes: Power Denial, Power Down, Active and Ringing
- Offhook detection with programmable thresholds for all operating modes
- Integrated Ring Trip Detection with zero crossing turn off function
- Ground Start and Loop Start possible
- Integrated checksum Calculation for CRAM
- Line Card Identification

2 Pin Configuration

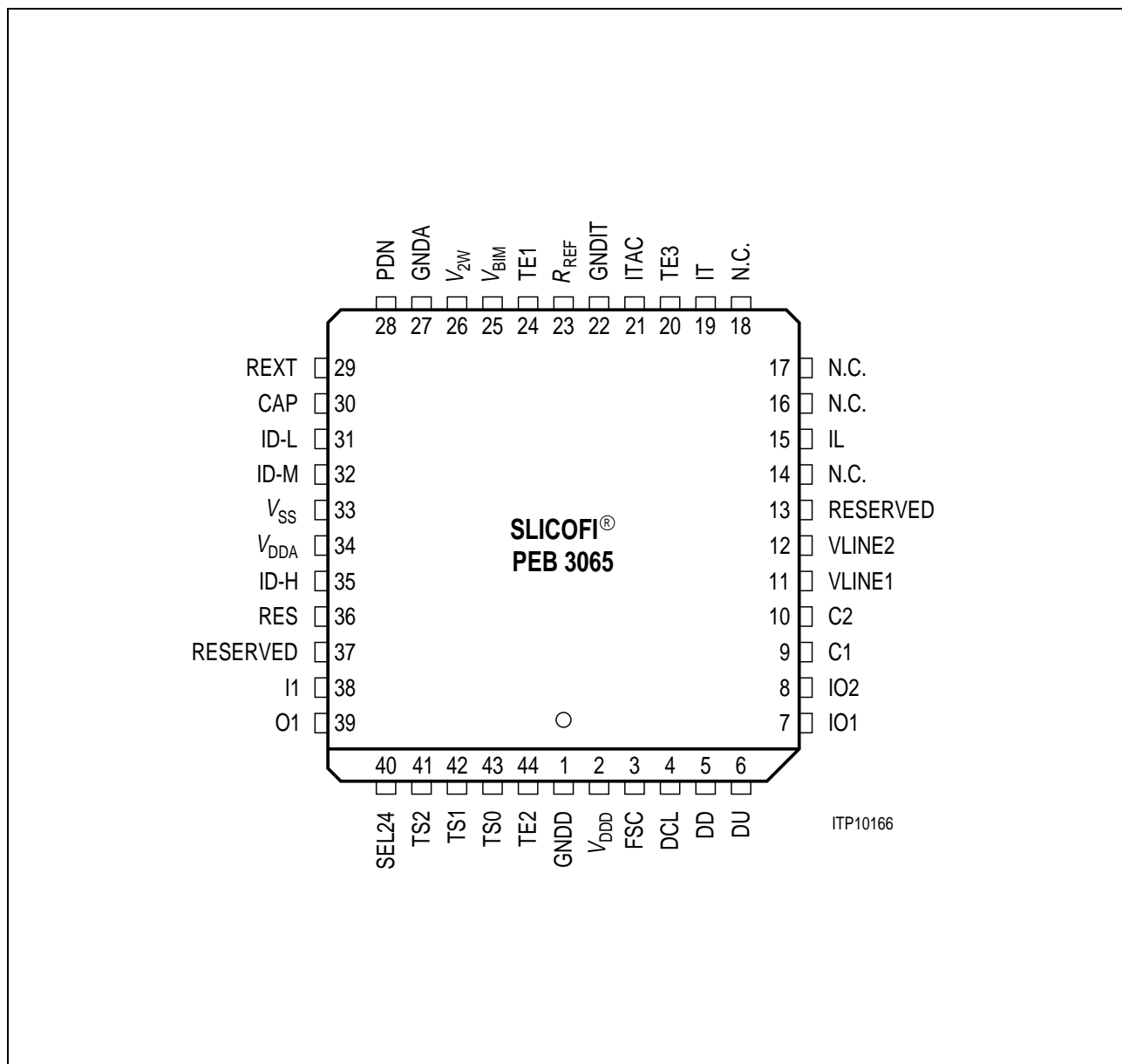

Figure 1

2.1 Pin Definition and Functions

The following tables group the pins according to their functions. They include pin number, pin name, type, a brief description of the function, and cross-references referring to the sections in which the pin functions are discussed.

Table 1

Pin No.	Name	Type	Function	Reference
27	GNDA	–	Analog Ground	chapter 9.1.1
1	GNDD	–	Digital Ground	chapter 9.1.1
34	V_{DDA}	–	+ 5 V Analog Supply Voltage	chapter 9.1.1
2	V_{DDD}	–	+ 5 V Digital Supply Voltage	chapter 9.1.1
33	V_{SS}	–	– 5 V Analog Supply Voltage	chapter 9.1.1

Table 2 IOM[®]-2 Pins

Pin No.	Name	Type	Function	Reference
6	DU	O	IOM-2 Data Upstream	chapter 4
5	DD	I	IOM-2 Data Downstream	chapter 4
4	DCL	I	IOM-2 Data-Clock	chapter 4
3	FSC	I	IOM-2 Frame-Sync.	chapter 4
43	TS0	I	Time Slot selection Pin 0	chapter 4
42	TS1	I	Time Slot selection Pin 1	chapter 4
41	TS2	I	Time Slot selection Pin 2	chapter 4
40	SEL24	I	Select DCL = 2 or 4 MHz	chapter 4

Table 3 Interface to HV-SLIC

Pin No.	Name	Type	Function	Reference
25	V_{BIM}	I	Battery Image Input	chapter 7
28	PDN	O	Set the HV-SLIC to Power Denial	chapter 7
19	IT	I	Transversal Current Input (AC + DC)	chapter 7
21	ITAC	I	Transversal Current Input (for AC)	chapter 7
22	GNDIT	I	Analog Ground	chapter 7
15	IL	I	Longitudinal Current Input	chapter 7

Pin Configuration

Table 3 Interface to HV-SLIC (cont'd)

Pin No.	Name	Type	Function	Reference
26	V_{2W}	O	Two Wire Output Voltage	chapter 7
9	C1	O	Ternary Interface to HV-SLIC	chapter 7
10	C2	O	Ternary Interface to HV-SLIC	chapter 7
11	$V_{LINE 1}$	I	Offhook-Detection in Power Denial Mode	chapter 7
12	$V_{LINE 2}$	I	Offhook-Detection in Power Denial Mode	chapter 7

Table 4 IO Pins

Pin No.	Name	Type	Function	Reference
7	IO1	I/O	User-Programmable I/O Pin	chapter 5.6
8	IO2	I/O	User-Programmable I/O Pin	chapter 5.6
38	I1	I	Fixed Input Pin	chapter 5.6
39	O1	O	Fixed Output Pin	chapter 5.6

Table 5 Miscellaneous Function Pins

Pin No.	Name	Type	Function	Reference Values
36	RES	I	Reset	chapter 6.1
30	CAP	I	External Capacitor to GNDA	68 nF 5%
23	RREF	I	External Resistor to GNDA	30 k 1%
29	REXT	I	External Ring Sync. Input	chapter 6.6
31	ID-L	I	External Identification (Pin strapping)	chapter 10.2
32	ID-M	I	External Identification (Pin strapping)	chapter 10.2
35	ID-H	I	External Identification (Connect ASIC)	chapter 10.2
20	TE3	O	Test Pin, mustn't be connected	–
24	TE1	–	Test Pin (Not connected)	–
44	TE2	O	Test Pin, mustn't be connected	–

Pin Configuration

Table 6 Pins not Used

Pin No.	Name	Type	Function	Reference
13	RESERVED	–	Reserved (not connected)	–
37	RESERVED	O	Reserved test pin, mustn't be connected	–
14	N.C.	–	Not connected (not used)	–
16	N.C.	–	Not connected (not used)	–
17	N.C.	–	Not connected (not used)	–
18	N.C.	–	Not connected (not used)	–

3 SLICOFI® Principles

Five Oversampling AD/DA converters are necessary for data conversion to gain the aspired programmability in the DSP. Generally the SLICOFI can be divided between the AC-Loop which is handling the voice and additionally teletax and the DC-Loop for line feeding, ringing injection and supervision.

3.1 SLICOFI® Signal Flow Graph: AC

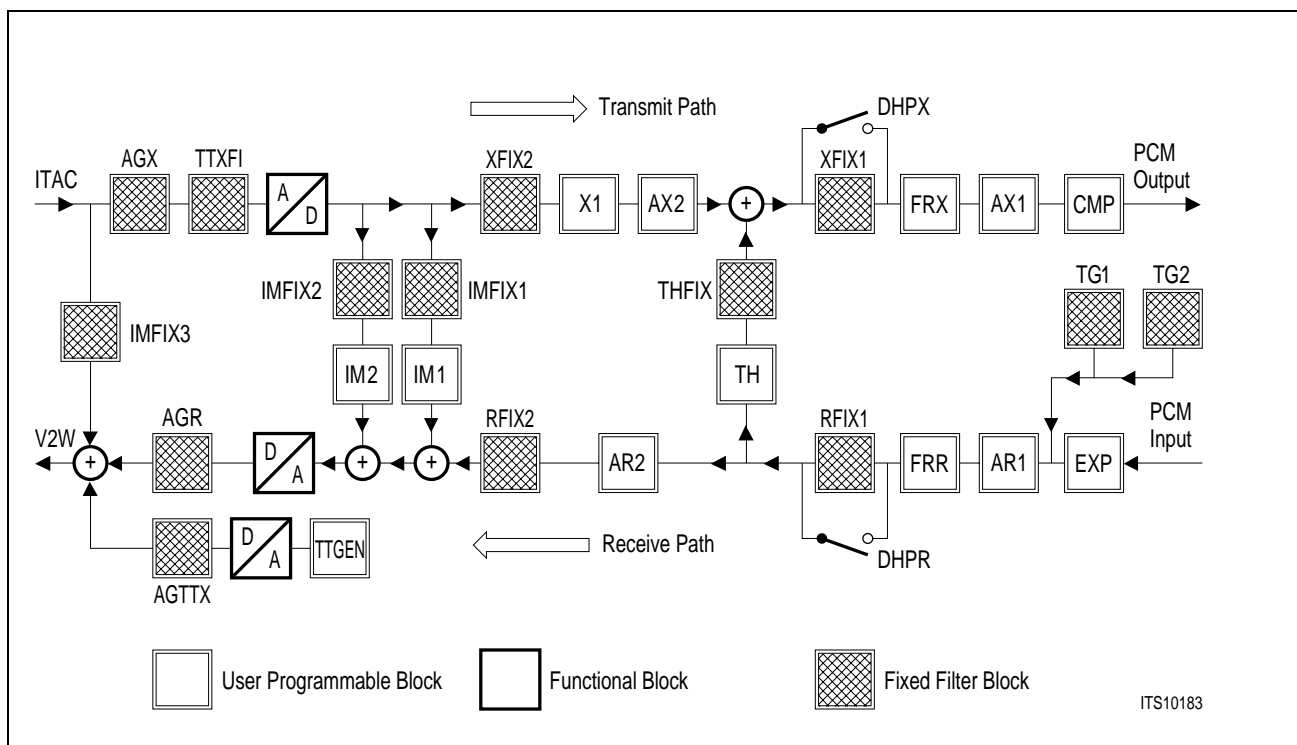

Figure 2

Transmit Path

The analog input signal has to be connected to pin 21 (ITAC) by an external capacitor (680 nF - 1 μF) for AC/DC separation. After passing a simple initializing prefilter (PREFI) the voice signal is converted to a 1-bit digital data stream in the ΣΔ-converter. The first down sampling steps are done in fast running digital hardware filters. The following steps are implemented in the micro code which has to be executed by the central Digital Signal Processor. This DSP-machine is able to handle the workload for the DC-loop as well. At the end the fully processed signal (flexibly programmed in many parameters) is transferred to the IOM-2 Interface in a PCM-compressed signal representation.

Receive Path

The digital input signal is received via the IOM-2 Interface. Expansion, PCM-lowpass-filtering, gain correction and frequency response correction are the next

steps which are done by the DSP-machine. The up sampling interpolation steps are again processed by fast hardware structures to reduce the DSP-workload. The upsampled 1-bit data stream is then converted to an analog equivalent which is smoothed by a POST-Filter (POFI). At the summing point the values of the TTX-Generator and the DC-loop are added and then transferred to the output pin 26 (V_{2W}).

Loops

There are two different loops implemented: The Impedance Matching (IM) loop which is divided in 3 separate loops to guarantee very high flexibility to various impedances, and the Transhybrid Balancing (TH) loop.

3.2 SLICOFI® Signal Flow Graph: DC

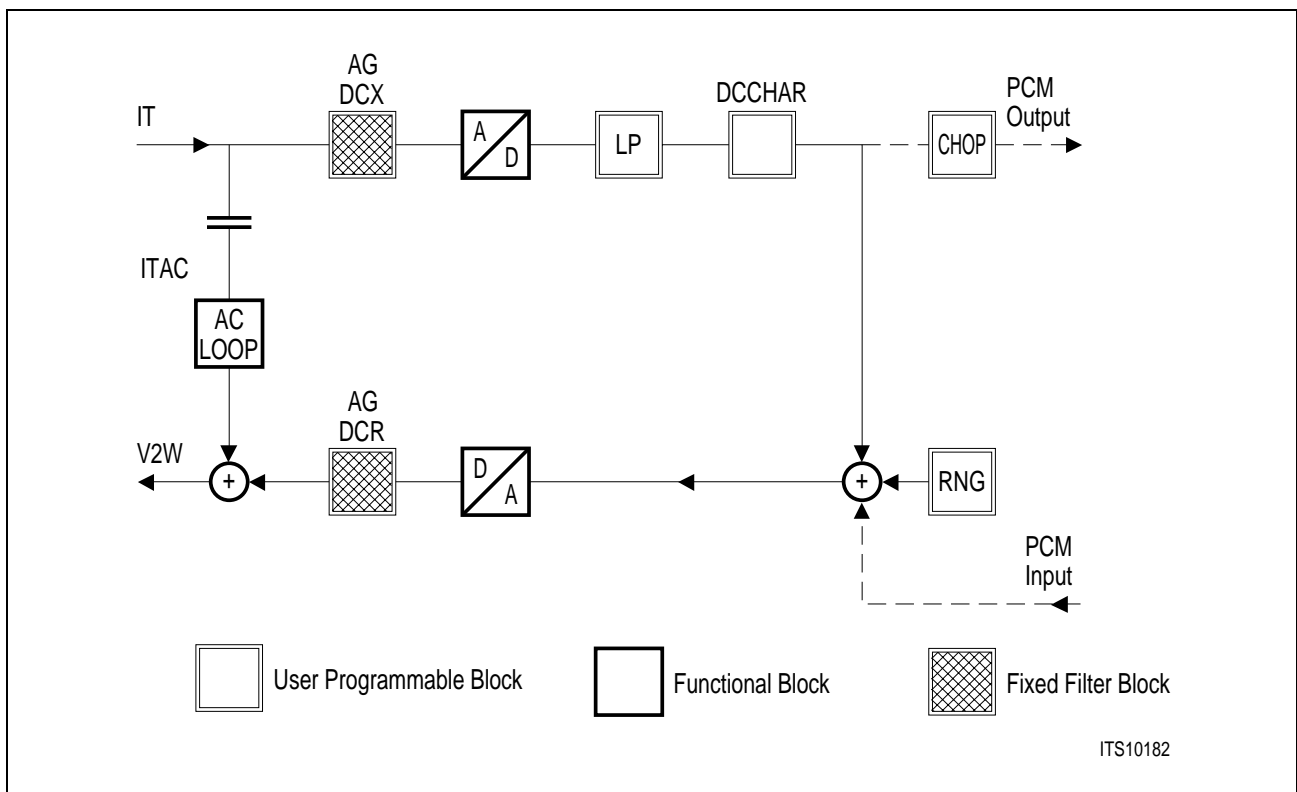

Figure 3

DC Characteristic

The incoming information at pin IT (scaled transversal current (AC + DC) transferred to a voltage via a resistor) is first lowpass filtered (0.3 Hz) for stability and noise reasons and then fed into the DC-characteristic block. This consists of two branches which represents different kinds of feeding behavior. In typical applications it acts as a programmable constant current source ($R_{in} > 30\text{ k}$). If the desired value cannot be held

SLICOFI® Principles

feeding switches automatically and smooth to the resistive branch ($R_{in} > 0-1 \text{ k}$). For superposing voice as well as Teletax pulses the necessary drop at the line can be calculated and taken into account as well. The outgoing DC-feeding value - superposed with the AC-Loop result at the summing point is transferred to pin 26 (V_{2W}).

Supervision

The HOOK-information is the most important one and the SLICOFI provides this information via CIDU (see **chapter 5.6**), in all operating modes:

For Power Denial via 2 high voltage input pins (V_{LINE}) directly connected to the line.

For each other mode the line current information (from pin IT) is transferred via an ADC to the DSP where the Offhook information is extracted in the proper way:

Power Down: Offhook is detected if Constant current feeding is possible.

Active: Offhook is detected if the incoming voltage at IT exceeds a programmed value. To avoid instable information, lowpass filtering and a hysteresis is provided (2 independent programmable values for Offhook and Onhook detection).

Ringling: Ring Trip occurs if the DC-value at IT exceeds the programmed Ring Trip threshold. The AC-value is filtered by the SLICOFI automatically. Ring Trip detection is reported within 2 cycles of the ring period and then the internal ring generator is switched off within 3 cycles at zero crossing of the ring voltage.

Ground key (CIDU-6: GNK) is reported if the absolute value of the voltage at pin IL exceeds 255 mV. With a programmable lowpass filter (see **chapter 5.6**) interfering frequencies (e.g. power lines with 50/60 Hz) can be filtered very effectively.

3.3 Test Features

The SLICOFI provides two different kinds of test features: Internal test loops for circuit testing and defined test loops to perform board and line tests. There are loops for testing AC and DC path. As a special feature it is possible to switch signals to and from the DC-path via the IOM-2 Interface. Additionally there is the possibility to cut off the AC-receive and transmit path.

(The different kinds of testmodes are described in **chapter 10.3**)

3.4 SLICOFI® Signal Block Diagram

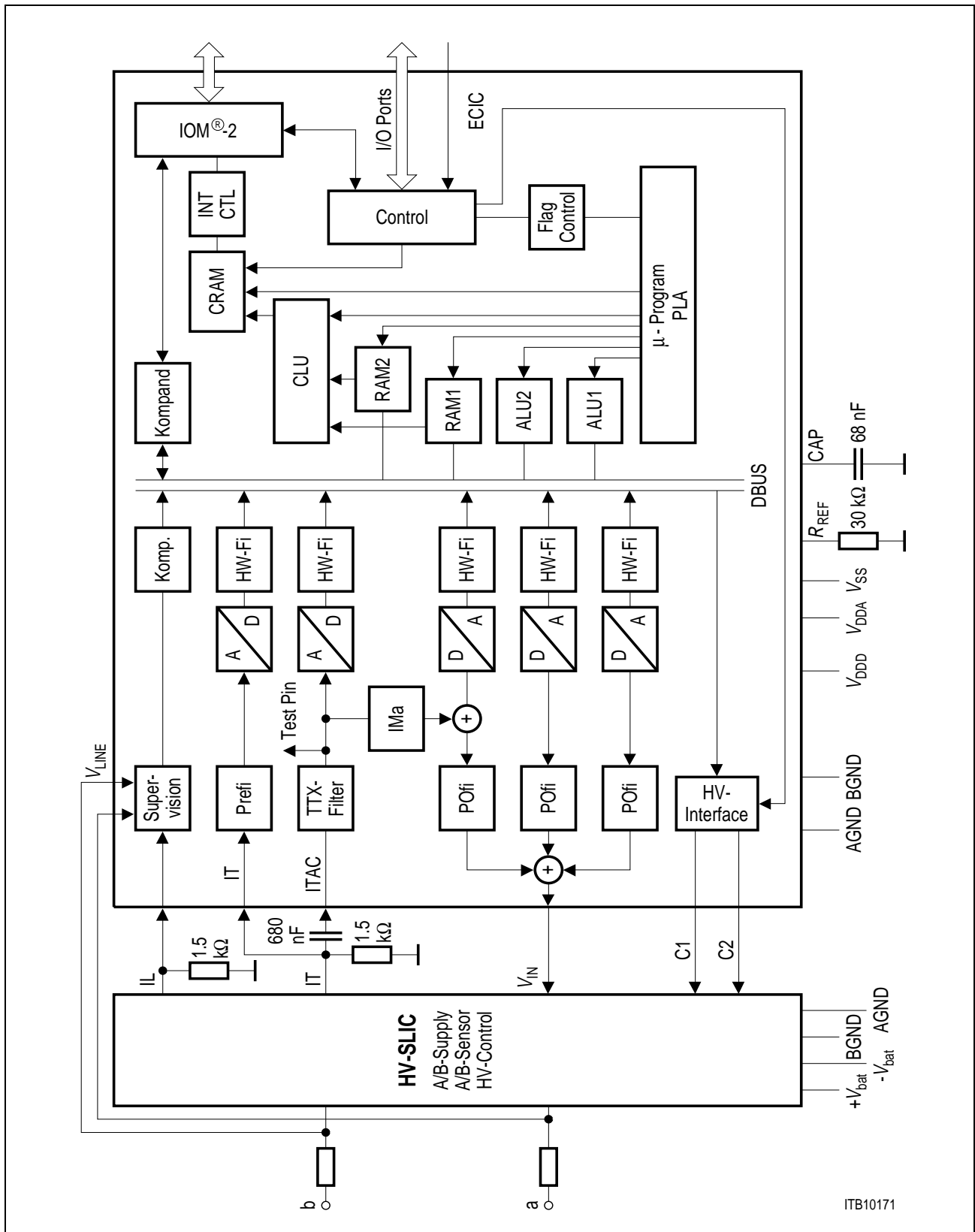

Figure 4

4 IOM[®]-2 Interface

The IOM-2 interface consists of two data lines and two clock lines. DU (data upstream) carries data from the SLICOFI to a master device. DD (data downstream) carries data from the master device to the SLICOFI. A frame synchronization clock signal (8 kHz, FSC) as well as a data clock signal (2048 kHz or 4096 kHz, DCL) has to be supplied to the SLICOFI. The SLICOFI handles data as described in the IOM-2 specification for analog devices.

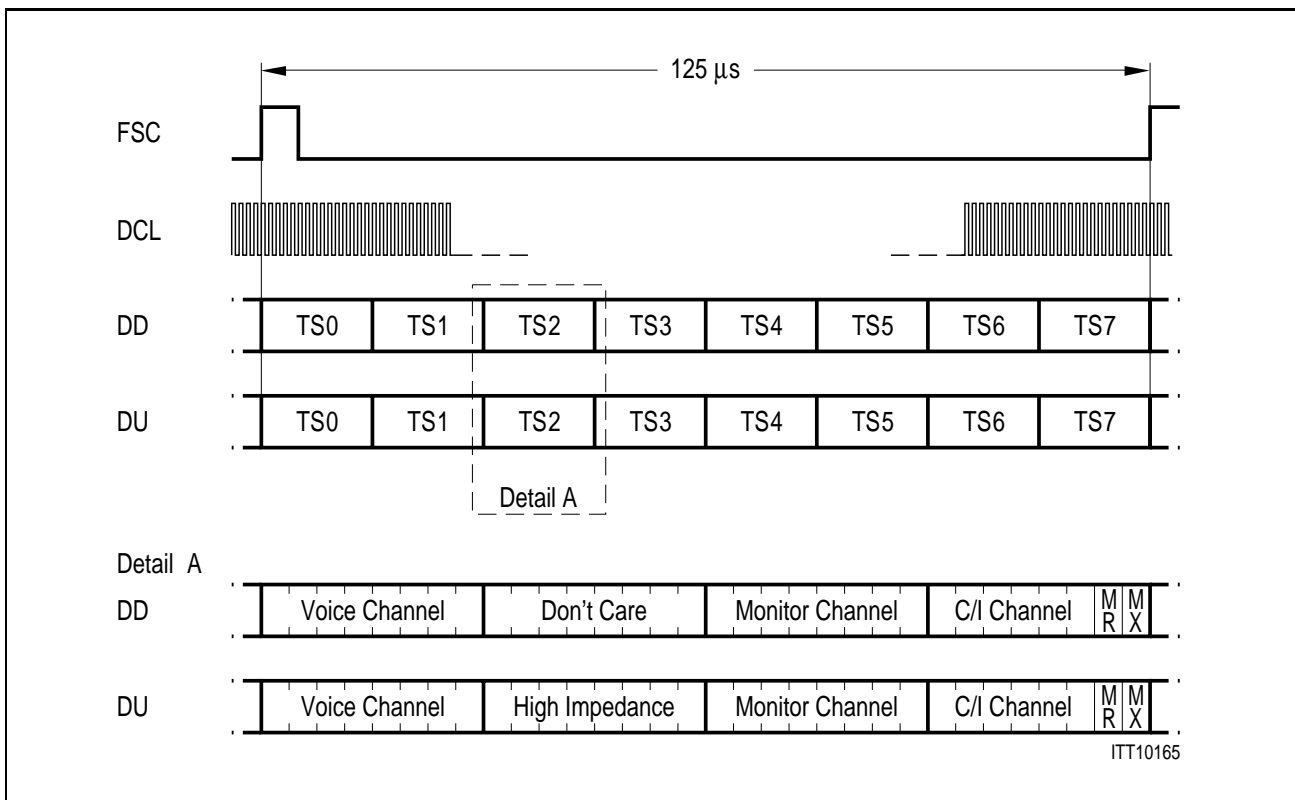

Figure 5 IOM[®]-2 Interface Timing for 8 voice channels (per 8 kHz frame)

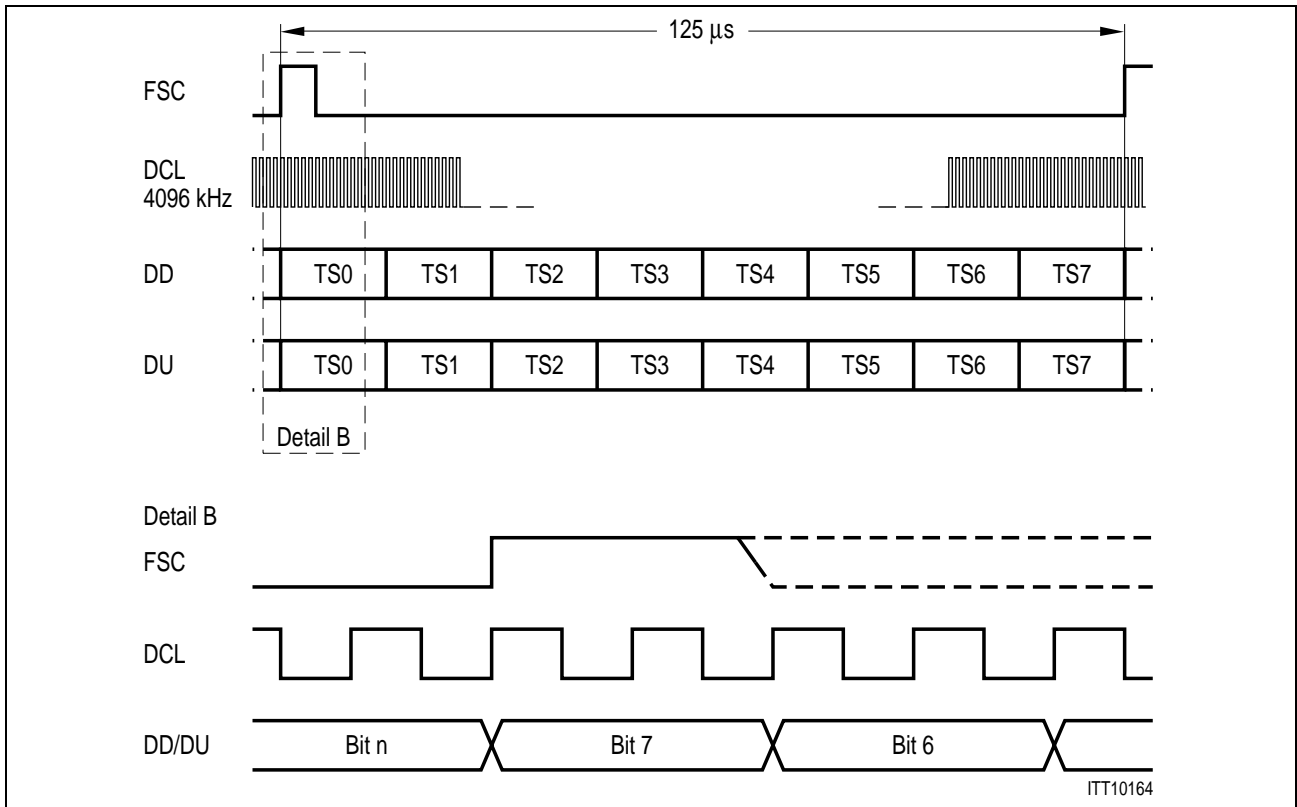

Figure 6 IOM[®]-2 Interface Timing (DCL = 4096 kHz, SEL24 = 1, per 8 kHz frame)

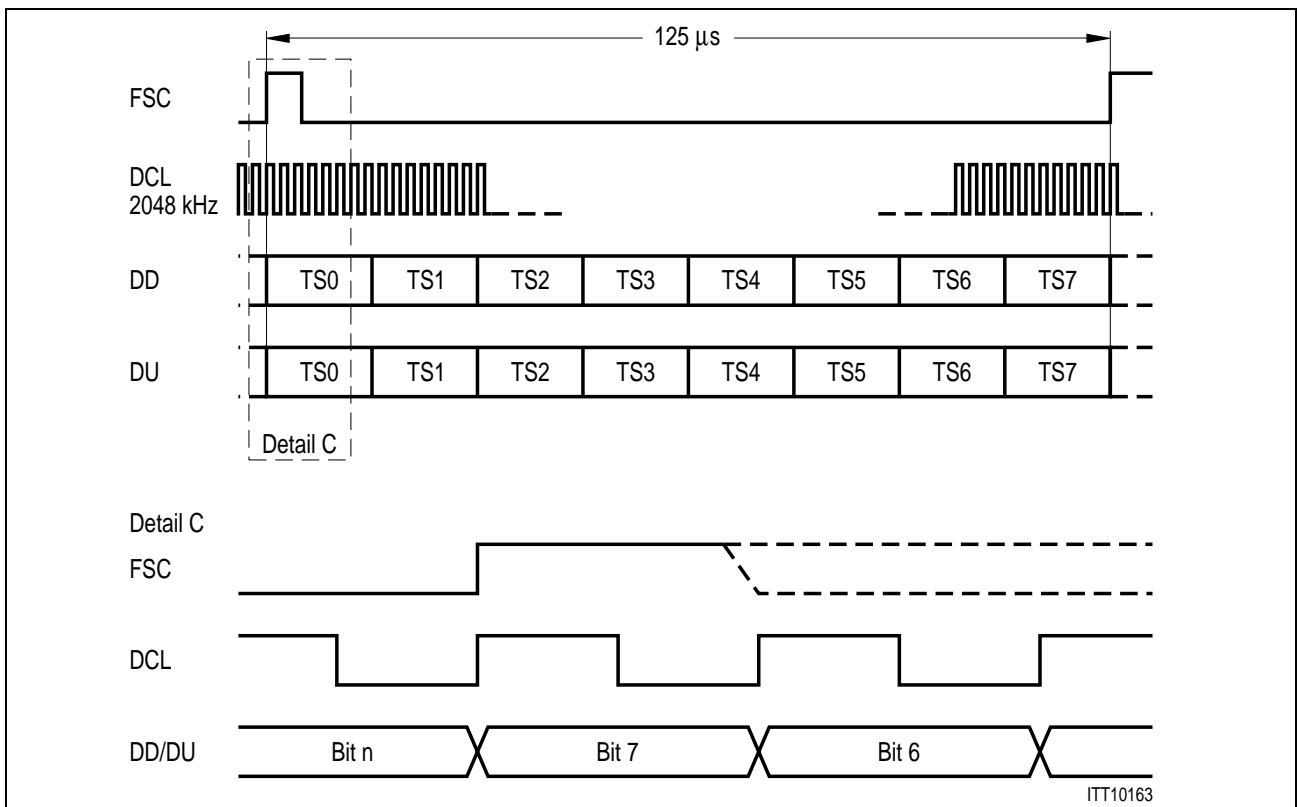

Figure 7 IOM[®]-2 Interface Timing (DCL = 2048 kHz, SEL24 = 0)

IOM[®]-2 Time Slot Assignment

An assignment of 8 time slots is possible for each voice-channel. The IOM-2 operating mode and time slot selection is set completely by pin-strapping.

Table 7

SEL24	TS2	TS1	TS0	IOM [®] -2 Operating Mode
0	0	0	0	Time slot 0; DCL = 2048 kHz
0	0	0	1	Time slot 1; DCL = 2048 kHz ¹⁾
0	0	1	0	Time slot 2; DCL = 2048 kHz ¹⁾
0	0	1	1	Time slot 3; DCL = 2048 kHz ¹⁾
0	1	0	0	Time slot 4; DCL = 2048 kHz
0	1	0	1	Time slot 5; DCL = 2048 kHz ¹⁾
0	1	1	0	Time slot 6; DCL = 2048 kHz
0	1	1	1	Time slot 7; DCL = 2048 kHz
1	0	0	0	Time slot 0; DCL = 4096 kHz
1	0	0	1	Time slot 1; DCL = 4096 kHz
1	0	1	0	Time slot 2; DCL = 4096 kHz
1	0	1	1	Time slot 3; DCL = 4096 kHz
1	1	0	0	Time slot 4; DCL = 4096 kHz
1	1	0	1	Time slot 5; DCL = 4096 kHz
1	1	1	0	Time slot 6; DCL = 4096 kHz
1	1	1	1	Time slot 7; DCL = 4096 kHz

¹⁾ Time slots 1, 2, 3 and 5 are not working with DCL = 2048 kHz.

For a workaround in the 2MHz mode please contact the SIEMENS HL Application group.

5 Programming the SLICOFI®

With the appropriate commands, the SLICOFI can be programmed and verified very flexible via the IOM-2 Interface monitor channel.

Data transfer to the SLICOFI starts with a SLICOFI-specific address byte (81_H).

With the second byte one of 3 different types of commands (SOP, TOP or COP) is selected. SOP and COP can be used as a write or read command, the TOP-Command is used for reading only. Due to the extended SLICOFI feature control facilities, SOP, COP and TOP commands contain additional information (e.g. number of subsequent bytes) for programming (write) and verifying (read) the SLICOFI status.

A write command is followed by up to 8 bytes of data. The SLICOFI responds to a read command with its IOM2 specific address and the requested information, that is up to 15 bytes of data (see **chapter 5.2**).

Attention: Each byte on the monitor channel has to be sent twice at least according to the IOM2 Monitor handshake procedure. (For more information on IOM-2 specific Monitor Channel Data Structure see **chapter 10**).

5.1 Types of Monitor Bytes

The 8-bit Monitor bytes have to be interpreted as either commands or status information stored in Configuration Registers or the Coefficient Ram. There are three different types of SLICOFI commands which are selected by bit 2 and 3 as shown below.

(x... don't care)

SOP Status Operation: SLICOFI status setting/monitoring

Bit	7	6	5	4	3	2	1	0
					0	1		

TOP Transfer Operation: Read Certain Status Options only

Bit	7	6	5	4	3	2	1	0
					1	1		

COP Coefficient Operation: filter coefficient setting/monitoring

Bit	7	6	5	4	3	2	1	0
					x	0		

Storage of programming information:

8 (9) status configuration registers: (SCR0), SCR1, ... SCR8 accessed by SOP commands

Programming the SLICOFI®

- 8 test configuration registers: STCR1...STCR8 accessed by SOP commands
- 18 Transfer configuration registers: TCR1, TCR2...TCR18 accessed by TOP commands
- 1 Coefficient RAM: CRAM accessed by COP commands

5.2 SLICOFI® Programming Procedure

(DD... Data Downstream, DU... Data Upstream, only the Monitor Bytes are considered)

SOP– Write Commands

DD	7	6	5	4	3	2	1	0	Bit	7	6	5	4	3	2	1	0	DU
Address	1	0	0	0	0	0	0	0	1	Idle								
SOP-Write 0 Byte		0			0	1	0	0		Idle								

DD	7	6	5	4	3	2	1	0	Bit	7	6	5	4	3	2	1	0	DU
Address	1	0	0	0	0	0	0	0	1	Idle								
SOP-Write 2 Bytes		0			0	1	0	1		Idle								
SCR1	Data								Idle									
SCR2	Data								Idle									

DD	7	6	5	4	3	2	1	0	Bit	7	6	5	4	3	2	1	0	DU
Address	1	0	0	0	0	0	0	0	1	Idle								
SOP-Write 8 Bytes		0			0	1	1	0		Idle								
SCR1	Data								Idle									
:	:								:									
SCR8	Data								Idle									

DD	7	6	5	4	3	2	1	0	Bit	7	6	5	4	3	2	1	0	DU
Address	1	0	0	0	0	0	0	0	1	Idle								
SOP-Write 8 Bytes		0			0	1	1	1		Idle								
STCR1	Data								Idle									
:	:								:									
STCR8	Data								Idle									

TOP – Write Commands

no write command possible; reading only.

COP – Write Commands

DD	7	6	5	4	3	2	1	0	Bit	7	6	5	4	3	2	1	0	DU
Address	1	0	0	0	0	0	0	0	1	Idle								
COP-Write 8 Bytes		0	0			0				Idle								
Coeff. 1	Data									Idle								
:	:									:								
Coeff. 8	Data									Idle								

SOP – Read Commands

DD	7	6	5	4	3	2	1	0	Bit	7	6	5	4	3	2	1	0	DU
Address	1	0	0	0	0	0	0	0	1	Idle								
SOP-Read 1 Byte		1			0	1	0	0		Idle								
	Idle								1	0	0	0	0	0	0	0	1	Address
	Idle								Data								SCR0	

DD	7	6	5	4	3	2	1	0	Bit	7	6	5	4	3	2	1	0	DU
Address	1	0	0	0	0	0	0	0	1	Idle								
SOP-Read 3 Bytes		1			0	1	0	1		Idle								
	Idle								1	0	0	0	0	0	0	0	1	Address
	Idle								Data								SCR0	
	Idle								Data								SCR1	
	Idle								Data								SCR2	

DD	7	6	5	4	3	2	1	0	Bit	7	6	5	4	3	2	1	0	DU
Address	1	0	0	0	0	0	0	0	1	Idle								
SOP-Read 9 Bytes		1				1	1	0		Idle								
	Idle								1	0	0	0	0	0	0	0	1	Address
	Idle								Data								SCR0	
	:								:								:	
	Idle								Data								SCR8	

Programming the SLICOFI®

DD	7	6	5	4	3	2	1	0	Bit	7	6	5	4	3	2	1	0	DU
Address	1	0	0	0	0	0	0	1		Idle								
SOP-Read 8 Bytes		1				1	1	1		Idle								
	Idle									1	0	0	0	0	0	0	1	Address
	Idle									Data								STCR1
	:									:								:
	Idle									Data								STCR8

TOP – Read Commands

DD	7	6	5	4	3	2	1	0	Bit	7	6	5	4	3	2	1	0	DU
Address	1	0	0	0	0	0	0	1		Idle								
TOP-Read 1 Byte		1			1	1	0	0		Idle								
	Idle									1	0	0	0	0	0	0	1	Address
	Idle									Data								TCR1

DD	7	6	5	4	3	2	1	0	Bit	7	6	5	4	3	2	1	0	DU
Address	1	0	0	0	0	0	0	1		Idle								
TOP-Read 3 Bytes		1			1	1	0	1		Idle								
	Idle									1	0	0	0	0	0	0	1	Address
	Idle									Data								TCR1
	Idle									Data								TCR2
	Idle									Data								TCR3

DD	7	6	5	4	3	2	1	0	Bit	7	6	5	4	3	2	1	0	DU
Address	1	0	0	0	0	0	0	1		Idle								
TOP-Read 15 Bytes		1			1	1	1	0		Idle								
	Idle									1	0	0	0	0	0	0	1	Address
	Idle									Data								TCR4
	:									:								:
	Idle									Data								TCR18

Programming the SLICOFI®

COP – Read Commands

DD	7	6	5	4	3	2	1	0	Bit	7	6	5	4	3	2	1	0	DU	
Address	1	0	0	0	0	0	0	0	1	Idle									
COP-Read 8 Bytes		1	0			0				Idle									
	Idle									1	0	0	0	0	0	0	0	1	Address
	Idle									Data								Coeff. 1	
	:									:								:	
	Idle									Data								Coeff. 8	

Example for a Mixed Command

DD	7	6	5	4	3	2	1	0	Bit	7	6	5	4	3	2	1	0	DU
Address	1	0	0	0	0	0	0	0	1	Idle								
SOP-Write 2 Bytes		0			0	1	0	1		Idle								
SCR1	Data									Idle								
SCR2	Data									Idle								
COP-Write 8 Bytes		0	0			0				Idle								
Coeff. 1	Data									Idle								
Coeff. 2	Data									Idle								
Coeff. 3	Data									Idle								
Coeff. 4	Data									Idle								
Coeff. 5	Data									Idle								
Coeff. 6	Data									Idle								
Coeff. 7	Data									Idle								
Coeff. 8	Data									Idle								
SOP-Read 3 Bytes		1			0	1	0	1		Idle								
	Idle									1	0	0	0	0	0	0	1	Address
	Idle									Data								SCR0
	Idle									Data								SCR1
	Idle									Data								SCR2
Address	1	0	0	0	0	0	0	0	1	Idle								
COP-Read 8 Bytes		1	0			0				Idle								
	Idle									1	0	0	0	0	0	0	1	Address

Programming the SLICOFI®

DD	7	6	5	4	3	2	1	0	Bit	7	6	5	4	3	2	1	0	DU	
	Idle									Data								Coeff. 1	
	Idle									Data								Coeff. 2	
	Idle									Data								Coeff. 3	
	Idle									Data								Coeff. 4	
	Idle									Data								Coeff. 5	
	Idle									Data								Coeff. 6	
	Idle									Data								Coeff. 7	
	Idle									Data								Coeff. 8	
Address	1	0	0	0	0	0	0	0	1		Idle								
TOP-Read 1 Byte		1			1	1	0	0			Idle								
	Idle									1	0	0	0	0	0	0	0	1	Address
	Idle									Data								TCR1	

5.3 SOP Command

To modify or evaluate the SLICOFI status, the contents of up to 8 configuration registers SCR1, ... SCR8 may be transferred to, or up to 9 (incl. SCR0) from the SLICOFI. This is done by a SOP-Command (status operation command).

With LSEL = 11 some test registers can be set/read (for internal use only!).

The two commands POLNR and RST are only valid if RW = 0 (write); they are ignored for RW = 1 (read)

Bit	7	6	5	4	3	2	1	0
	0	RW	POLNR	RST	0	1	LSEL1	LSEL0

RW Read/Write Information: Enables reading from the SLICOFI or writing information to the SLICOFI

RW = 0 Write to SLICOFI

RW = 1 Read from SLICOFI

POLNR General DC feeding Information: Normal or Reverse Polarity

POLNR = 0 sets the SLICOFI to Normal Polarity feeding

POLNR = 1 sets the SLICOFI to Reverse Polarity feeding

RST Software Reset

RST = 0 Normal Operation

RST = 1 Reset SLICOFI (same as Reset pin 36 (RES)): sets the SLICOFI to the basic setting mode (see **chapter 6.1**).

LSEL Length select information (also see programming procedure, **chapter 5.2**).

This field identifies the number of subsequent data bytes

If RW = 0 Write to SLICOFI

LSEL = 00 no byte of data is following

LSEL = 01 2 bytes of data are following (SCR1, SCR2)

LSEL = 10 8 bytes of data are following (SCR1,... SCR8)

LSEL = 11 Accesses Test Registers (see Appendix)

If RW = 1 Read from SLICOFI

LSEL = 00 1 byte of data is following (SCR0)

LSEL = 01 3 bytes of data are following (SCR0, SCR1, SCR2)

LSEL = 10 9 bytes of data are following (SCR0, ... SCR8)

LSEL = 11 Accesses Test Registers (see Appendix, **chapter 10.3**)

SCR0 Configuration Register 0

Configuration Register SCR0 can be read only. It gives a mirror of the SOP-Command itself to control its contents and represents the reset value as defined below.

Bit	7	6	5	4	3	2	1	0
	0	1	POLNR	RSTST	0	1	LSEL1	LSEL0

Reset value: 54_H (if only SCR0 is read. It depends on LSEL1 and LSEL0.)

POLNR General DC feeding Information: Normal or Reverse Polarity
 POLNR = 0 indicates, that the SLICOFI was set to Normal Polarity feeding
 POLNR = 1 indicates, that the SLICOFI was set to Reverse Polarity feeding¹⁾

RSTST Status of Reset
 Indicates the occurrence of a reset:
 RSTST = 1 if there has been a Reset by any of the following three reasons:
 – via the Reset-pin (RES)
 – via the Power on Reset
 – via the Software Reset (SOP-Command)
 the RSTST-bit is set to '1'.
 RSTST = 0 no Reset has occurred since the last SOP-Read (with LSEL = 00b).
 This bit is cleared only by a SOP-read with LSEL = 00b at the end of the data transmission.

LSEL is the mirror of the SOP-Read LSEL contents.

¹⁾ The internal manipulation with "Reverse meterpulses" is not indicated by that bit.

SCR1 Configuration Register 1

Configuration register SCR1 defines the basic feeding modes of the SLICOFI and enables/disables test features:

Bit	7	6	5	4	3	2	1	0
	PD	N/BB	LB	ETG1	HI-b	HI-a	DHP-X	COR

Reset value: 00_H

- PD** SLICOFI is set either in Power Down or Power Denial mode together with CIDD-bits CIDD6,7 (see **chapter 6**).
 PD = 0 SLICOFI set to Power Denial mode; line supervision via $V_{LINE1,2}$
 PD = 1 SLICOFI set to Power Down mode
- N/BB** SLICOFI is in normal or Boosted Battery mode (see **chapter 6.5**).
 N/BB = 0 Normal feeding
 N/BB = 1 Changes ternary interface to HV-SLIC which sets the HV-SLIC to Boosted Battery mode
- LB** Handling of Loop Back functions for on chip test loops
 LB = 0 normal function
 LB = 1 the desired Loop Back function (analog or digital) is enabled (selected by SCR6, together with the TM-bit (SCR2-3))
- ETG1** Enables programmable Test Tone Generator 1
 ETG1 = 0 Test Tone Generator 1 is disabled
 ETG1 = 1 Test Tone Generator 1 is enabled
- HI-b** For HV-SLIC test function
 HI-b = 0 normal operation
 HI-b = 1 changes ternary Interface to HV-SLIC which sets the b-leg of the line into high impedance state
- HI-a** For HV-SLIC test function
 HI-a = 0 normal operation
 HI-a = 1 changes ternary Interface to HV-SLIC which sets the a-leg of the line into high impedance state
- DHP-X** Disable Transmit Highpass for test reasons (see **chapter 10.3**)
 DHP-X = 0 Transmit Highpass Filter is enabled
 DHP-X = 1 Transmit Highpass Filter is disabled
- COR** Cut Off Receive Path for test reasons (see **chapter 10.3**)
 COR = 0 Receive Path transmission is available
 COR = 1 Receive Path is disabled

SCR2 Configuration Register 2

Configuration register SCR2 defines some testmode output results, some special SLMA-mode requirements and the possibility to program 2 I/O-ports.

Bit	7	6	5	4	3	2	1	0
	MVA	OKTON	OKTTX	OKRNG	TM	NOSL	IO1	IO2

Reset value: 00_H (then as measured)

- MVA** Internal measurement results shown in the following 3 bits are valid or not valid (read only) (see **chapter 10.3**)
MVA = 0 the following 3 ok-bit results are not valid
MVA = 1 the following 3 ok-bit results are valid
- OKTON** Test Tone measurement information (read only) - programmed via COP-command (Testloop: DLB_4M and TG1 enabled, see **chapter 10.3**)
OKTON = 0 Test tone value out of defined range
OKTON = 1 Test tone value in defined range
- OKTTX** Test teletax metering information (read only) - programmed via COP-command (see **chapter 10.3**)
OKTTX = 0 Test teletax metering value smaller than defined value
OKTTX = 1 Test teletax metering value larger than defined value
- OKRNG** Test Ring tone information (read only) – programmed via COP-command (see **chapter 10.3**)
OKRNG = 0 Ring tone value smaller than defined value
OKRNG = 1 Ring tone value larger than defined value
- TM** enables or disables the SLICOFI Testmodes (see **chapter 10.3**)
TM = 0 resets the assigned tests (normal mode)
TM = 1 sets the assigned tests (selected by SCR6, together with the LB-bit (SCR1-5))
- NOSL** No slope: means that the ramping of teletax (TTX) signal is switched off
NOSL = 0 Slope of TTX-Signal is smooth
NOSL = 1 Hard switch of TTX-Signal
- IO1** Selection for programmable IO - Pin IO1
IO1 = 0 sets the pin IO1 as an input
IO2 = 1 sets the pin IO1 as an output
- IO2** Selection for programmable IO - Pin IO2
IO1 = 0 sets the pin IO2 as an input
IO2 = 1 sets the pin IO2 as an output

SCR3 Configuration Register 3

Configuration register SCR3 defines the meterpulse settings and the Data Upstream Persistency Counter.

Bit	7	6	5	4	3	2	1	0
	TTXNO	TTX12	SOREV	PDADIS	DUP3	DUP2	DUP1	DUP0

Reset value: 8A_H

- TTXNO** Meterpulses are represented by teletax (TTX) with 12 or 16 kHz or with Reverse Polarity
 TTXNO = 0 Meterpulses are represented with 12 kHz or 16 kHz
 TTXNO = 1 Meterpulses are represented with Reverse Polarity
- TTX12** Teletax-signal with 12 kHz or 16 kHz
 TTX12 = 0 16 kHz teletax-signal
 TTX12 = 1 12 kHz teletax-signal
- SOREV** The reversal pulse is either soft or hard
 SOREV = 0 hard reversal
 SOREV = 1 soft reversal

Note: For proper function special coefficients generated by SLICOS should be used.

To realize this function following settings must be done:

1. Enable the testregisters (Configuration Register 5: SCR5-1 (ENTR)=1), (page 32)
2. The testregisterblock must be load with STCR3-0 (SOFTVER) = 1, (see chapter 10.3)

STCR3 Test Configuration Register 3

Bit	7	6	5	4	3	2	1	0
	0	0	0	0	0	0	0	1

3. SCR3-5 (SOREV) = 1

PDADIS The automatic HV-SLIC Power Down - Active switching (see **chapter 6.4**) can be switched off
 PDADIS = 0 use automatic Power Down-Active switching
 PDADIS = 1 disables automatic Power Down-Active switching

DUP To restrict the rate of upstream C/I-bit changes, deglitching (persistence checking) of the status information from the SLICOFI may be applied. New status information will be transmitted upstream, after it has been stable for N milliseconds. N is binary programmable in the range of 1 to 15 ms in steps of 1 ms; with DUP = 0_H the deglitching is disabled. Reset value is 10 ms. The HOOK, SLCX and the I(O)-bits are influenced (different counters but same programming). Detailed info see **chapter 5.4**.

SCR4 Configuration Register 4

Configuration register SCR4 defines the basic SLICOFI settings which enable / disable the programmable digital filters and the second tone generator.

Bit	7	6	5	4	3	2	1	0
	TH	IM	FRX	FRR	AX	AR	ETG2	PTG

Reset value: 00_H

TH	Set transhybrid Balancing Filter – together with the bit FIXC (SCR5-5). For FIXC = 1 the TH-Filter is set to $H_{TH} = \text{for } Z_{BRD}$; for FIXC = 0: TH = 0 TH-filter is disabled TH = 1 TH-filter is enabled (use programmed values)
IM	Set DSP-implemented Impedance Matching Filter - together with the bit FIXC (SCR5-5). For FIXC = 1 the IM-Filter is set to $H_{IM} = \text{for } 900$; for FIXC = 0: IM = 0 IM-filter is disabled IM = 1 IM-filter is enabled (use programmed values)
FRX	Enable FRX- (Frequency Response Transmit) Filter FRX = 0 FRX-filter is disabled ($H_{FRX} = 1$) FRX = 1 FRX-filter is enabled (use programmed values)
FRR	Enable FRR- (Frequency Response Receive) Filter FRR = 0 FRR-filter is disabled ($H_{FRR} = 1$) FRR = 1 FRR-filter is enabled (use programmed values)
AX	Set AX- (Amplification/Attenuation Transmit) Filter AX = 0 AX-filter is set to default value ($H_{AX} = 10 \text{ dB}$) AX = 1 AX-filter is enabled (use programmed values)
AR	Set AR- (Amplification/Attenuation Receive) Filter AR = 0 AR-filter is set to default value ($H_{AR} = -15.11 \text{ dB}$) AR = 1 AR-filter is enabled (use programmed values)
ETG2	Enable programmable Test Tone Generator 2 ETG2 = 0 Test Tone Generator 2 is disabled ETG2 = 1 Test Tone generator 2 is enabled
PTG	User programmable frequency or fixed frequency is selected PTG = 0 fixed frequency for both Test Tone Generators TG1 = 1008 Hz, TG2 = 2 kHz PTG = 1 programmed frequency for both Test Tone Generators

SCR5 Configuration Register 5

Configuration register SCR5 defines various different features.

Bit	7	6	5	4	3	2	1	0
	DHP-R	LAW	FIXC	LIN	IDR	REXTEN	ENTR	0

Reset value: 20_H

- DHP-R** Disable Receive Highpass for test reasons (see **chapter 10.3**)
DHP-R = 0 Receive Highpass Filter is enabled
DHP-R = 1 Receive Highpass Filter is disabled
- LAW** PCM - law selection
LAW = 0 A-Law is selected
LAW = 1 μ -Law (μ 255 PCM) is selected
- FIXC** The SLICOFI uses either fixed coefficients or the programmed ones.
FIXC = 0 programmed coefficients used
FIXC = 1 fixed coefficients used
fixed coefficients: (see **chapter 6.2**)
- LIN** Linear mode selection (16 bit linear information in voice channel A (upper byte) and B (lower byte)).
LIN = 0 PCM-mode is selected
LIN = 1 linear mode is selected
- IDR** Initialize Data RAM
IDR = 0 normal operation is selected
IDR = 1 contents of Data RAM is set to 0 (for test purposes)
- REXTEN** Ringing External
REXTEN = 0 normal operation
REXTEN = 1 used for external (unbalanced) ringing
- ENTR** Enable Test Mode Register
ENTR = 0 normal operation: the contents of the Test Registers are permanently set to the default values
ENTR = 1 the contents of the Test Registers can be changed

SCR6 Configuration Register 6

Configuration register SCR6 defines various test features and test loops.

Bit	7	6	5	4	3	2	1	0
	COT8	COT16	OPIMAN	OPIM4M	TEST LOOPS			

Reset value: 00_H

- COT8** Cut Off Transmit Path at 8 kHz for test reasons (Input of Compression)
 COT8 = 0 transmit path transmission is enabled
 COT8 = 1 transmit path is disabled (output is zero for μ -law and linear mode, + 1 (= LSB) for A-law)

- COT16** Cut Off Transmit Path at 16 kHz for test reasons (Input of TH-Filter)
 COT16 = 0 transmit path transmission is enabled
 COT16 = 1 transmit path is disabled

- OPIMAN** Open analog Impedance Matching Loop (IMAN)
 OPIMAN = 0 normal operation
 OPIMAN = 1 opens analog IM-Loop ($H_{IMAN} = 0$)

- OPIM4M** Open fast digital Impedance Matching Loop (IM4M)
 OPIM4M = 0 normal operation
 OPIM4M = 1 opens fast digital IM-Loop ($H_{IM4M} = 0$)

- TEST LOOPS** 4 bit field for various analog and digital test loops can be set together with LB and TM (see **chapter 10.3**, for detailed information).

SCR7 Configuration Register 7

Configuration register SCR7 is the Mask register. With it each bit of TCR1 (Signalling register) can be masked; that means changes of such a “masked bit” are not causing a change of the SLCX - bit (Data Upstream C/I-channel byte).

Bit	7	6	5	4	3	2	1	0
	HOOKM	GNKM	VB/2M	ICONM	TEMPM	CFAILM	1	1

Reset value: FF_H

HOOKM Mask bit for Offhook information
 HOOKM = 0 each change of the HOOK bit leads to an interrupt (SLCX-bit)
 HOOKM = 1 changes of HOOK bit are neglected

GNKM Mask bit for ground key information
 GNKM = 0 each change of the GNK bit leads to an interrupt (SLCX-bit)
 GNKM = 1 changes of GNK bit are neglected

VB/2M Mask bit for half battery information
 VB/2M = 0 each change of the VB/2 bit leads to an interrupt (SLCX-bit)
 VB/2M = 1 changes of VB/2 bit are neglected

ICONM Mask bit for constant current information
 ICONM = 0 each change of the ICON bit leads to an interrupt (SLCX-bit)
 ICONM = 1 changes of ICON bit are neglected

TEMPM Mask bit for over temperature information
 TEMPM = 0 each change of the TEMP bit leads to an interrupt (SLCX-bit)
 TEMPM = 1 changes of TEMP bit are neglected

CFAILM Mask bit for clock fail information
 CFAILM = 0 each change of the CFAIL bit leads to an interrupt (SLCX-bit)
 CFAILM = 1 changes of CFAIL bit are neglected

Information about changing half battery- and constant current- information will be neglected on both of the Power Denial and the Ringing state, and information about changing ground key information will be neglected in the Power Denial state.

SCR8 Configuration Register 8

Configuration register SCR8 defines some Test Mode Settings and the Ground Key/External Indication Data Upstream Persistency Counter.

Bit	7	6	5	4	3	2	1	0
	DCANAL	CHOPACT	DCHOLD	EXT_MCLK 1	DUPGNK3	DUPGNK2	DUPGNK1	DUPGNK0

Reset value: 05_H

- DCANAL** Test bit to shorten internally the IT with the V_{2W} pin
 DCANAL = 0 normal operation
 DCANAL = 1 the DC Analog Loop is closed
- CHOPACT** Transforms DC-Test values to 500 Hz rectangular values at the PCM interface
 CHOPACT = 0 normal operation
 CHOPACT = 1 chopping function is activated
- DCHOLD** Holds the actual DC-value at the V_{2W} output
 DCHOLD = 0 normal operation
 DCHOLD = 1 hold DC-value at V2W
- EXT_MCLK1** External Masterclock (16 MHz)
 EXT_MCLK1 = 0 internal masterclock is used
 EXT_MCLK1 = 1 external masterclock is used
- To use an external masterclock of 16 MHz following steps must be done:
1. IO1 must be set to input and becomes the input-pin of the masterclock (**page 42**)
 2. Connect the internal clockline to IO1 and disable the PLL by setting the bit EXT_MCLK1 = 1
- DUPGNK** To restrict the rate of upstream C/I-bit changes, deglitching (persistence checking) of the status information from the SLICOFI may be applied. New status information will be transmitted upstream, after it has been stable for N milliseconds. N is binary programmable in the range of 4 to 60 ms in steps of 4 ms, with DUPGNK = 0h the deglitching is disabled. Reset value is 20 ms.
 The HOOK bit (for external Indication) and the GNK bit are influenced. Detailed info see **chapter 5.6**.

5.4 TOP Command

If no status modification of the SLICOFI is required (there is no TOP-write operation) a transfer operation byte TOP may be transferred.

Bit	7	6	5	4	3	2	1	0
	0	RW	0	0	1	1	LSEL1	LSEL0

RW Read Information: Enables reading from the SLICOFI

RW = 0 No operation

RW = 1 Read from SLICOFI

LSEL Length select information (also see programming procedure, **chapter 5.2**). This field identifies the number of subsequent data bytes.

LSEL = 00 Read TCR1 (Signalling Register) only

LSEL = 01 Read 3 bytes of data (TCR1, TCR2, TCR3)

LSEL = 10 Read extended line card design and configuration information only (TCR4, ... TCR18).

Details see **chapter 10.2**

LSEL = 11 future reserved

TCR1 Configuration Register 1

TCR1 is the Signalling register. It indicates status information. If there is any change of one or more bit, it is indicated via the SLCX bit in the C/I-channel. Each bit can be masked by SCR7 Register.

Bit	7	6	5	4	3	2	1	0
	HOOK	GNK	VB/2	ICON	TEMPA	CFAIL	x	x

Reset value: 00_H

HOOK Loop information On/Offhook (same as in C/I-channel)

HOOK = 0 Onhook

HOOK = 1 Offhook

GNK Ground key or Ground start information via IL-pin (same as in C/I-channel)

interrupt masked in Power Denial State

GNK = 0 no longitudinal current detected

GNK = 1 longitudinal current detected

Programming the SLICOFI®

VB/2	Half battery voltage across the HV-SLIC is detected (V_{2W} compared to $V_{BIM}/2$) interrupt masked in Power Denial and Ringing State VB/2 = 0 line voltage smaller than half battery ($ V_{2W} > V_{BIM}/2 $) VB/2 = 1 line voltage larger than half battery ($ V_{2W} < V_{BIM}/2 $)
ICON	Current limitation information interrupt masked in Power Denial and Ringing State ICON = 0 Resistive Feeding ICON = 1 Constant Current Feeding
TEMPA	Temperature alarm of the HV-SLIC which is signalled through the HV-SLIC Interface (see chapter 7). TEMPA = 0 normal temperature TEMPA = 1 Temperature alarm from HV-SLIC detected
CFAIL	Clock Fail: Not the right count of clock cycles between two frame syncs CFAIL = 0 no clock fails detected CFAIL = 1 clock fails detected The CFAIL bit is not influenced by the DUP-counter (each failure is reported).
x	undefined

Any change of these bits is signalled via the interrupt-bit (SLCX) in the C/I-DU-channel. There are two types of generating an interrupt:

- Each toggling of a non-masked TCR1-bit combined with a DUP-counter
- Toggling of the non-masked CFAIL-bit (no filtering by the DUP-counter)

The status information is stored in the TCR1-register by an interrupt or - if there is no interrupt - before reading this register only.

The HOOK- and the GNK-input are directly filtered by an own DUP-/DUPGNK-counter too and they are also directly included in the C/I-DU-channel.

Reading the TCR1-register is possible in two ways:

- Reading only TCR1 (TOP-command with LSEL = 0b)
- Reading TCR1 with other TCR-registers (TOP-command with LSEL = 0b)

The first way gives the actual status of all TCR1-inputs if the internal interrupt is not active and actualizes the TCR1-register.

Is the interrupt active the content of TCR1-register is read and the interrupt is cleared.

The second way gives the content of TCR1-register and nothing will be changed.

The following figure shows the flow diagram of the interrupt logic.

TCR2 and TCR3 Configuration Registers 2 and 3

TCR2 and TCR3 are the checksum of all the Coefficient bytes written into the Coefficient RAM (CRAM) of the SLICOFI by the COP-Command.

TCR2

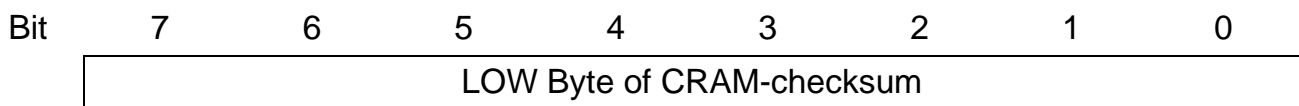

TCR3

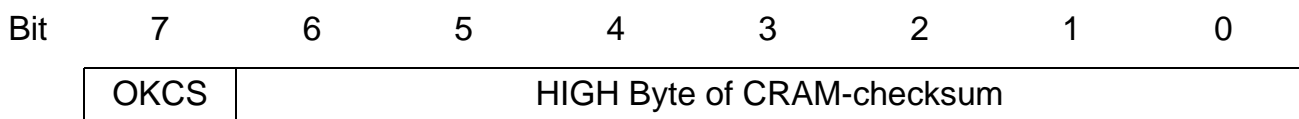

OKCS shows, if the checksum is valid or the internal checksum calculation is not yet finished ¹⁾

OKCS = 0 checksum is not valid

OKCS = 1 checksum is valid

Algorithm of defining the checksum: $x^{16} x^{10} x^7 x 1$

With that algorithm you can reach a fault coverage of: $(1 - 2^{-15})$

¹⁾ After each change of the CRAM contents (COP-write or COP-read) the checksum has to be recalculated. During calculation time OKCS = 0.

TCR4 to TCR18: Configuration Register 4 to 18

These 15 bytes are the possible design information bytes which are described in **chapter 10.2** more detailed for the extended IOM-2 Channel Identification Command using an external ASIC.

TCR4

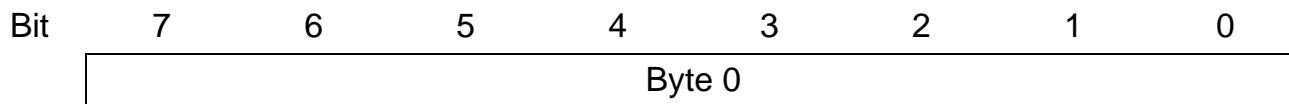

TCR5

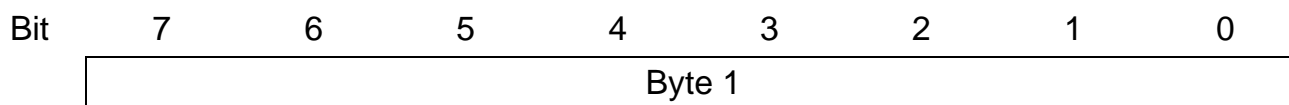

TCR18

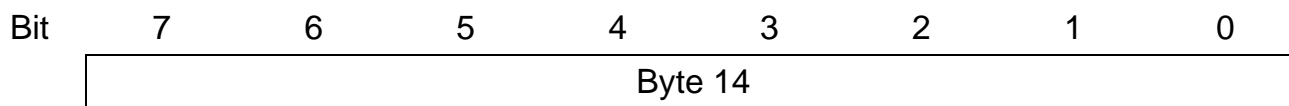

TCR4 - TCR18 show the contents of the serial input of the ASIC via IDH-pin.

5.5 COP Command

With a COP Command coefficients for the programmable filters can be written to the SLICOFI Coefficient RAM or read from the Coefficient RAM via the IOM-2 interface for verification. (Filter optimizing to different applications is supported by the software package SLICOS.)

Bit	7	6	5	4	3	2	1	0
		RW	CODE 4	CODE 3	CODE 2	0	CODE 1	CODE 0

RW Read / Write
 RW = 0 Subsequent data is written to the SLICOFI
 RW = 1 Read data from the SLICOFI

CODE includes number of following bytes and filter-addresses¹⁾

0	0	0	0	0	0	TH-Filter coefficients (part 1)	(followed by 8 bytes of data)
0	0	0	0	0	1	TH-Filter coefficients (part 2)	(followed by 8 bytes of data)
0	0	0	0	1	0	TH-Filter coefficients (part 3)	(followed by 8 bytes of data)
0	0	0	0	1	1	IM-Filter coefficients (part 1)	(followed by 8 bytes of data)
0	0	1	0	0	0	IM-Filter coefficients (part 2)	(followed by 8 bytes of data)
0	0	1	0	0	1	FRX-Filter coefficients	(followed by 8 bytes of data)
0	0	1	0	1	0	FRR-Filter coefficients	(followed by 8 bytes of data)
0	0	1	0	1	1	DC-Loop coefficient (part 1)	(followed by 8 bytes of data)
0	1	0	0	0	0	DC-Loop coefficient (part 2)	(followed by 8 bytes of data)
0	1	0	0	0	1	DC-Loop coefficient (part 3)	(followed by 8 bytes of data)
0	1	0	0	1	0	TTX and DC-Loop coefficient	(followed by 8 bytes of data)
0	1	0	0	1	1	AX-Filter coefficients	(followed by 8 bytes of data)
0	1	1	0	0	0	AR-Filter coefficients	(followed by 8 bytes of data)
0	1	1	0	0	1	TG1-Filter+BP1+LM-BP coefficients	(followed by 8 bytes of data)
0	1	1	0	1	0	TG2-Filter+BP2 coefficients	(followed by 8 bytes of data)
0	1	1	0	1	1	Testing (levelmeter) coefficients	(followed by 8 bytes of data)

¹⁾ For generating a correct checksum all not used bits must be set to '0'.

5.6 IOM®-2 Interface Command / Indication Byte

The Command/Indication (C/I) channel is used to communicate real time status information and for fast controlling of the SLICOFI. Data on the C/I channel is continuously transmitted in each frame until new data is to be sent.

Data Downstream C/I - Channel Byte (receive) - CIDD

Note that there is no address DD direction because there is only one SLICOFI per IOM2-channel. This byte is used for fast controlling of the SLICOFI. Each transfer to the SLICOFI has to last for at least 2 consecutive frames (FSC-cycles) so that it is accepted internally. Changes (spikes) of less than 2 FSC cycles are neglected.

Bit	7	6	5	4	3	2
	RING	CONV	TIM	IO1	IO2	O1

RING see table below (for details see **chapter 6**).

CONV see table below (for details see **chapter 6**).

Table 8

RING	CONV	Description
0	0	Power Denial or Power Down State (depending on PD-bit (SCR1-7))
0	1	Active State
1	0	Power Down or (automatic) Power Down Ring Pause
1	1	(normal) Ringing State

TIM Timing bit to control the timing of ringing or meterpulses (for details see **chapter 6**).

TIM = 0 SLICOFI is in the ringing pause or no meterpulse is on.

TIM = 1 SLICOFI is in the ringing phase or output of a meterpulse is running.

IO1 Value for the programmable Input/Output Pin IO1 (Pin 7) if programmed as an output pin. If the bit REXTEN (SCR5-2) is set to 1 (external ringing) the internally created Ring Burst On Signal (for an external relay driver) is switched to the IO1 pin instead of the IO1-bit (for more details see **chapter 6 , page 51**).

IO1 = 0 The corresponding pin at the digital interface of the SLICOFI is set to a logic 0.

IO1 = 1 The corresponding pin at the digital interface of the SLICOFI is set to a logic 1.

Programming the SLICOFI®

- IO2** Value for the programmable Input/Output Pin IO2 (Pin 8) if programmed as an output pin.
- IO2 = 0 The corresponding pin at the digital interface of the SLICOFI is set to a logic 0.
- IO2 = 1 The corresponding pin at the digital interface of the SLICOFI is set to a logic 1.
- O1** Value for the fixed Output Pin O1 (Pin 39).
- O1 = 0 The corresponding pin at the digital interface of the SLICOFI is set to a logic 0.
- O1 = 1 The corresponding pin at the digital interface of the SLICOFI is set to a logic 1.

Data Upstream C/I - Channel Byte (transmit) - CIDU

Note that there is no address in DU direction too. This byte is used for fast transfer of the most important and time critical informations from the SLICOFI.

Bit	7	6	5	4	3	2
	HOOK	GNK	SLCX	IO1	IO2	I1

- HOOK** Indication of the loop condition (filtered via the DUP-counter or the DUGNK-counter in Power Denial State).
- HOOK = 0 Subscriber is Onhook.
- HOOK = 1 Subscriber is Offhook.
- GNK** Indication if a ground connection is detected (filtered via the DUGNK-counter). The function is disabled in Power Denial State (GNK is set to 0).
- GNK = 0 No ground connection detected.
- GNK = 1 Ground connection detected.
- SLCX** Interrupt bit: Summary output of the whole signalling register (TCR1) if they are not masked - filtered via the DUP counter (see SCR7; the interrupt logic is described in detail in **chapter 5.4, page 36**).
- SLCX = 0 No unmasked bit in the signalling register has toggled.
- SLCX = 1 Any unmasked bit in the signalling register has toggled.
- IO1** Logical state of the programmable Input/Output Pin IO1 (Pin 7) - even if not programmed as an input pin.¹⁾
- IO1 = 0 The corresponding pin at the digital interface of the SLICOFI is receiving a logic 0.
- IO1 = 1 The corresponding pin at the digital interface of the SLICOFI is receiving a logic 1.

Programming the SLICOFI®

- IO2** Logical state of the programmable Input/Output Pin IO2 (Pin 8) - even if not programmed as an input pin.¹⁾
- IO2 = 0 The corresponding pin at the digital interface of the SLICOFI is receiving a logic 0.
- IO2 = 1 The corresponding pin at the digital interface of the SLICOFI is receiving a logic 1.
- I1** Logical state of the programmable Input Pin I1 (Pin 38).
- I1 = 0 The corresponding pin at the digital interface of the SLICOFI is receiving a logic 0.
- I1 = 1 The corresponding pin at the digital interface of the SLICOFI is receiving a logic 1.

The DUP- (DUPGNK) - counters filter the status-information and the input-pin I1 respectively. The counters count down and generate enable-signals for the registers if they are zero. Then they start counting again at the programmed value. If a status-information or an input-signal changes the proper counter is set and continues counting down. There are three different DUP-counters for HOOK, SLCX and the input-pin and one DUPGNK-counter for HOOK in PDen-mode or GNK in all other modes. Changing the mode freezes the actual status of HOOK and sets the actual HOOK-counter.

¹⁾ If the Input/Output Pin is programmed as an output the corresponding bit in the CIDU is '1'

6 Operating Modes

The SLICOFI supports 4 different Operating Modes: Power Denial (PDen), Power Down (PDown), Active and Ringing which are controlled via the upper 3 bits of the Data Downstream C/I channel byte (CIDD).

Table 9

RiING-(CIDD7)	CONV-(CIDD6)	TiIM-(CIDD5)	Mode
0	0	x	PDen: PD (SCR1-7) = 0
0	0	x	PDown: PD (SCR1-7) = 1
1	0	0	PDown (Ring Pause)
0	1	0	Active
0	1	1	Active with Meterpulse on
1	x	1	Ringing: Ring Burst On
1	1	0	Ringing: Ring Pause

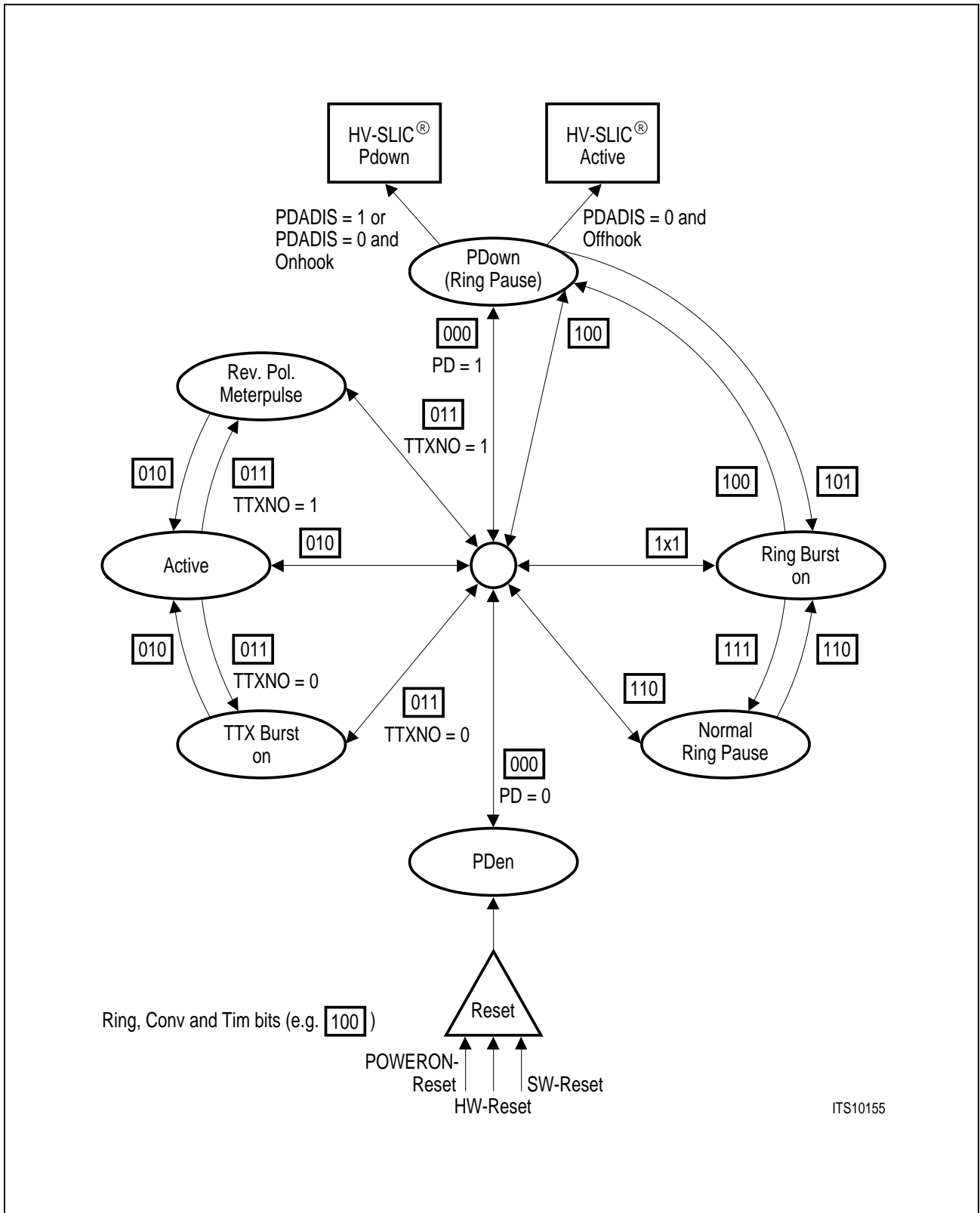

Figure 9

6.1 Reset Behavior

The SLICOFI has 3 different reset sources that are all internally connected.

The Reset pin RES (pin 36), which works totally asynchronous to the external clocks.

The Reset bit (Within SOP - command, bit 4). The reset is valid for SOP-write only.

Power On Reset. If internal V_{DD} gets above 1.5 Volts the SLICOFI is Reset by Power On Reset.

All 3 different sources set the SLICOFI to the basic setting modes (see below).

After a reset caused by any of the sources mentioned above, the reset bit (SCR0-4 = RSTST) in read direction is set to one. This bit is cleared (RSTST = 0) after it has been read by a SOP-read operation with the LSEL bits set to 00b (means: read only SCR0 byte). A SOP-read with other LSEL bits reads the actual RSTST value, but does not clear it.

The Reset pin RES has a Schmitt-Trigger input to reduce the sensitivity for spikes. In addition the pin RES has a spike rejection. All spikes smaller than typ. 70 ns are neglected. The pin RES can be set to 1 for an unlimited time but at least 125 μ s is recommended; during that, the DU pin is set to high impedance.

The SLICOFI leaves this mode automatically with the beginning of the next 8 kHz-frame (or after pin RES is released).

6.2 Basic Setting Modes

After RESET, the SLICOFI automatically is switched to its basic settings in which it uses internal default values for all filters and settings (AC and DC), so that the SLMA still works in a kind of “emergency mode” and can be handled by C/I-Interface commands only.

This means that for an (un-)determined reset (e.g. Power On Reset) the SLICOFI is reset, but can be switched to or return automatically to any operating mode presented to the C/I-channel after 2 FSC cycles. In all modes the SLMA stays stable, supervision and DC-feeding are still working and conversation can go on in a proper way until all filters and settings have been reloaded by SOP and COP-commands.

So what happens internally after reset?

- all configuration registers are set to their default values (note that the Coefficient RAM is **not** reset)
- the RSTST-bit (SCR0-4) is set to 1 to indicate that a reset has taken place
- The IOM-2 interface is reset. Running communication is stopped
- DU is in high impedance state
- AC- and DC-loop use the default values and not the programmed ones (see below)

Operating Modes

Table 10 DC

Parameter	Values	Unit	Test Condition/Result
Const I	26	mA	limit for Constant Current (for Active and Power Down)
RFS	2 × 150		Feeding Resistance (for Active and Power Down - excluding the external Fuse resistors)
V_{drop}	10	V	Overall voltage drop (to reach maximum length and there is no Teletax)
f_{Ring}	25	Hz	Ring Frequency
ARing	1.7	V	Ring rms-value at V_{2W}
PDen	1.45	Vrms	Power Denial Voltage for Offhook
Offhook	8	mA	Offhook Detection (for Power Down, Ringing and Active without hysteresis)
DC-Lowpass	0.3/5	Hz	DC- Lowpass set to 0.3 and 5 Hz respectively
Levelmeter			undefined (parameters stored in CRAM)
DUP	10	ms	Data Upstream Persistency Counter is set to 10 ms
DUPGNK	20	ms	Data Upstream Persistency Counter for GNK is set to 20 ms

Boosted Battery is reset to normal feeding

Reverse Polarity is reset to Normal Polarity

all bits of the Signalling Register are masked and reset to 0

the Data Upstream C/I channel byte is reset to 0 (and IO's are set to Input pins)

C1 and C2 are set to PDNR and PDN is set high

A-Law is chosen

Table 11 AC

Parameter	Values	Unit	Test Condition/Result
IM-Filter	900		Approximately 900 Real Input Impedance
TH-Filter	TH_{BRD}		Approximately BRD-Impedance for Balanced Network
AX	10	dB	Attenuation Transmit (this means about 0 dB for SLMA)
AR	- 15.11	dB	Attenuation Receive (this means about - 7 dB for SLMA)
ATTX	190	mV	Teletax Generator Amplitude at V_{2W} ; but note that the SLICOFI is set to TTXNO = 1 with reset

Table 11 AC (cont'd)

Parameter	Values	Unit	Test Condition/Result
f_{TTX} SOREV	16	kHz	Teletax Generator frequency; but note that the SLICOFI is set to TTXNO = 1 with reset for Metering with Polarity Reversal: Hard Reversal is used.
TG1	1008	Hz	Tone Generator 1 and AC-levelmeter Bandpass
TG2	2000	Hz	Tone Generator 2 (+ 2 dB compared to TG1)

6.3 Power Denial (PDen)

After a Reset (including the Power On Reset) the SLICOFI is set to Power Denial State. In Power Denial all functions that are not necessary are disabled to minimize power consumption. Via the two pins V_{LINE1} and V_{LINE2} the SLICOFI is directly connected to the a - and b - wire, while the PDN-Pin is set high (which turns off the HV-SLIC). While the interface is fully working - including programmability of the registers with SOP- or TOP commands and the Coefficient RAM (COP commands) the rest of the SLICOFI is turned off except the supervision of the line. The change of the line state is reported via the HOOK-bit in the IOM-2 Data upstream channel. To avoid spurious Offhook - informations caused by longitudinal induction the HOOK - bit is low pass filtered (programmable with the DUPGNK - counter in PDen state only). The HV-interface pins C1, C2 are switched off. The voice channel Data Downstream is directly fed into the voice channel Data Upstream. The HOOK-indication in PDen is optimized for longitudinal suppression up to 65 Vrms for the Offhook transition.

6.4 Power Down (PDown)

In Power Down Mode the DC-Loop of the SLICOFI is fully working; the AC-Loop is still turned off. The output voltage at the V2W pin is controlled via the IT input in such a way that it behaves like a programmable constant current source. Current limitation is used for detecting Offhook, too. The change of the line state is reported via the HOOK-bit in the IOM-2 Data upstream channel. To avoid spurious Offhook-informations the HOOK-bit is lowpass filtered (programmable with DUP-counter).

The ternary HV-interface (C1, C2) is set to Power Down mode. If Offhook is detected the HV-interface is set to one of the active modes. This can be avoided by setting PDADIS = 1 (SCR3-4). Then the HV-SLIC interface is set to Power Down anyway.

The longitudinal current supervision via the IL pin is activated in this mode.

The voice channel Data Downstream is directly fed into the voice channel Data Upstream.

Together with the bits Hi-a and Hi-b of the configuration register 1 (SCR1-2 and SCR1-3) simple handling of Ground Start function is possible.

Table 12

	Pin No./Pin Name								
	CIDD7	CIDD6	CIDD5	SCR1-7	SCR1-3	SCRI1-2	PIN 28	PIN 9	PIN 10
	RING	CONV	TIM	PD	HI-b	HI-a	PDN	C1	C2
PDNH - Loop open (I _{ab} < 30 μA)	0	0	1	x	x	x	1	V _{OL}	V _{OL}
PDNR	0	0	0	0	not (11)		1	V _{OZ}	V _{OZ}
PDown	0	0	0	1	0	0	0	V _{OH}	V _{OH}
PDown (with HI-a)	0	0	0	1	0	1	0	V _{OL}	V _{OH}
PDown (with HI-b)	0	0	0	1	1	0	0	V _{OZ}	V _{OH}
b-line high impedance (Ground Start)	0	0	0	x	1	1	0	V _{OZ}	V _{OH}

6.5 Active Mode (Act)

In Active Mode (“Conversation State”) both AC-and DC-Loop are fully working. The output voltage at the V_{2W} pin is controlled via the IT input pin in such way, that it behaves like a constant current source which turns automatically into a programmable resistive feeding source due to the DC-Characteristic values (see **chapter 3.2, page 13** for more details).

The ternary HV-interface is set to one of the active modes.

Polarity

The SLICOFI supports either normal or reverse Polarity which is set by the POLNR-bit (SOP-5). The information is transferred to the HV-Interface and simultaneously a 180 degree phase shift of the AC- and DC-Loop is done. The performance and the functionality is not influenced by that.

Boosted Battery

To feed subscriber lines with enhanced loop resistance the SLICOFI supports the Boosted Battery mode. The HV-Interface pins are set to Boosted Battery (BB) mode and the maximum V_{2W} output voltage is extended to – 3.2 V.

Meterpulses

The SLICOFI supports two different kinds of meterpulses: Meterpulses with 12/16 kHz (Teletax Metering) and with polarity reversal. In the Active Mode the Timing bit (TIM) controls the meterpulse which might be 12/16 kHz **or** reversal. The decision between

these two ways is made by the bit TTXNO (SCR3-7). If bit TTXNO is set to 1, then the meterpulse is reversal. In this case the Timing bit is linked to POLNR (SOP-5) by an EXOR gate. If bit TTXNO is set to 0, then the Timing bit and POLNR are completely independent from another and Teletax Metering is used.

Metering with Polarity Reversal

Hard or Soft (SOREV, SCR 3-5)

As long as the TIM bit of the C/I-channel is set to 1, the SLICOFI is changing the actual polarity of the HV-Interface and performs an immediate 180 degree phase shift of the AC- and DC-Loop.

Teletax Metering Injection

For countries with Teletax Metering, the SLICOFI provides either a 12 or 16 kHz Signal (switchable with the bit TTX12 (SCR3-6))¹⁾ which amplitude is free programmable up to 250 mVrms at V_{2W} . The SLICOFI filters the Teletax pulses in transmit direction, too. The slope of the pulses are internally shaped, so that the noise during switching and transmission is less than 50 mV at V_{2W} and 1 mV at the IOM-2 interface (psophometrically weighted). With the bit NOSL (SCR2-2) the slope can be switched off. In that case the switching noise is not defined (for signalling only).

6.6 Ringing Mode

The SLICOFI generally supports balanced ringing.

If the SLICOFI is set to Ringing Mode, the HV-Interface is set to Ringing Mode, the AC-loop is turned off and the DC-Loop is automatically opened.

The voice channel Data Downstream is directly fed into the voice channel Data Upstream.

Balanced Ringing

The sine wave of the ringing is generated in the SLICOFI. The frequency and the amplitude are free programmable between 16 and 70 Hz and up to 2.125 Vrms at V_{2W} , respectively²⁾. In Ring Pause 0 V is provided at V_{2W} . If the Ring Burst On (RBO) command is sent to the SLICOFI via the C/I-channel (RING and TIM = 1) the begin and end (TIM = 0) of the ring burst is automatically synchronized at the voltage zero crossing. If the DC-current at the IT-pin exceeds the programmed value, Offhook is detected within 2 periods of the ringing frequency and the Ring Burst at V_{2W} is switched off within 3 periods. During Offhook the Ring Burst On command is neglected.

¹⁾ Note, that the right Teletax Coefficient Set (via COP-command) must be provided, too.

²⁾ Note that the DC-value is 0. So DC injection has to be performed by the HV-SLIC.

Unbalanced (external) Ringing

The sine wave for ringing is generated by an external ring generator. To coordinate with the SLICOFI following settings must be done:

1. IO1 set as an output
2. SCR5-2 (REXTEN) = 1
3. RING-(CIDD7) = 1 (PDown: Ring Pause)
4. TIM-(CIDD5) = 1 (Ringing: Ring Burst On)

Pin REXT: a positive puls according to zerocrossing of the ringer voltage

RINGING:

5. signal for relays on IO1
6. HV-SLIC in PDen Mode
7. SLICOFI in PDown Mode, Offhook-detection via $V_{LINE1,2}$

RING PAUSE:

8. TIM-(CIDD5) = 0 (PDown: Ring Pause), Offhook-detection via IT (in the same way as balanced ringing)

7 SLIC Interface

2 Wire Output Voltage (V_{2W})

The V_{2W} output voltage pin (26) represents the sum for AC- and DC-loop together with Teletax info or Ring Burst at the receive path. The buffer is designed for a load of $R_L > 600$ and $C_L < 10$ pF and directly connected to the HV-SLIC in typical applications.

Transversal Current Sense AC - Input (ITAC)

The pin ITAC (21) is the input voltage pin for the AC transversal current information from the HV-SLIC in the transmit path. AC/DC separation is done by an external highpass filter (capacitor range between 680 nF - 1 μ F). The input resistance is larger than 20 k. Current/voltage conversion is done via an external resistor (same for pin IT).

Transversal Current Sense DC - Input (IT)

The pin IT (19) is the input voltage pin for the DC transversal current information from the HV-SLIC in the transmit path. The signal is internally filtered via a 0.3 Hz lowpass. The input resistance is larger than 20 k. Current/voltage conversion is done via an external resistor (same for pin ITAC).

Longitudinal Current Sense - Input (IL)

The scaled longitudinal current information transferred from the HV-SLIC – the current-voltage conversion is done by an external resistor – is lowpass filtered (time programmable using DUPGNK-counter) and is reported via the Data Upstream C/I-channel (CIDU-6). In Power Denial, the GNK-bit is set to '0' and the setting of the Interrupt bit (CIDU-5) caused by GNK is prohibited. Changing from PDen to any other mode, the DUPGNK-counter is set to the programmed value; so the change of the GNK information (CIDU-6) is lowpass filtered anyway.

Battery Image Input (V_{BIM})

The information about the actually used battery voltage (V_{BAT}) of the SLMA is transferred from the HV-SLIC via the V_{BIM} pin to the SLICOFI. In order to give some information about the operating point of the SLMA there is a comparison of the actual battery voltage and the output voltage V_{2W} of the SLICOFI. This information is transferred via the Signalling register (TCR1-5: VB/2).

If $|V_{2W}| < |V_{BIM} / 2|$ the VB/2-bit is set to 1, else to 0.

Ternary Interface (C1, C2) and HV-SLIC Switch Off Output (PDN)

In order to set the HV-SLIC to the different operating states, the information of the SLMA-controller is passed through from the IOM-2-channel to the ternary HV-SLIC-Interface pins C1 and C2.

Table 13

		C2 (PIN 10)		
		VOL	VOZ	VOH
C1 (PIN 9)	VOL	RING RP/PDNH	RING NP	HI-a
	VOZ	BB RP	BB NP/PDNR	HI-b
	VOH	Active RP	Active NP	PDown

- BB - Boosted battery
- RP - Reverse Polarity
- NP - Normal Polarity
- HI-b - High Impedance b-leg
- HI-a - High Impedance a-leg
- PDNH - Power Denial High Impedance
- PDNR - Power Denial Resistive

For signalling “Over temperature” the HV-SLIC drains a current (I_{OT}) from pin 9. The message is transferred via the Signalling register (TCR1-3). This is possible in any operating states of the HV-Interface except for Power Denial.

The HV-SLIC (PEB 4065) has two different Power Denial Modes:

1. PDNR, the resistive mode which provides a connection of 15 kΩ from TIP and RING to BGND and V_{BAT} , respectively
2. PDNH, offers high impedance at TIP and RING

In this mode (PDN = 1) the HV-SLIC is completely turned off. Line supervision is done via the $V_{LINE1,2}$ pins. In all other modes, PDN is set to GND ($R_{ON} < 250 \Omega$).

Line Sense Pins ($V_{LINE1,2}$)

In Power Denial state the line supervision is done via the $V_{LINE1,2}$ pins. If the voltage V_{LINE} between the two pins exceeds the programmed value, Offhook is reported via the Data Upstream C/I-channel (CIDU-7)¹⁾. To reach the longitudinal voltage suppression, the incoming signal is low pass filtered using the values that are programmed by the DUPGNK counter (no longitudinal current information present in PDen, but the same interferences).

¹⁾ Note: $V_{LINE} = V_{LINE1} - V_{LINE2}$; so the voltage of V_{LINE1} has to be higher than V_{LINE2} for correct external indication

8 Transmission Characteristics

The target figures in this specification are based on the subscriber-line board requirements. The proper adjustment of the programmable filters (transhybrid balancing, impedance matching, frequency-response correction) needs a complete knowledge of the SLICOFI's analog environment. Unless otherwise stated, the transmission characteristics are guaranteed within the test conditions.

Test Conditions

$T_A = 0\text{ }^{\circ}\text{C}$ to $70\text{ }^{\circ}\text{C}$;

$V_{DDD} = V_{DDA} = 5\text{ V} \pm 5\%$; $V_{SS} = -5\text{ V} \pm 5\%$; $GNDA = GNDD = 0\text{ V}$

$R_L > 600\text{ }\Omega$; $C_L < 10\text{ pF}$ (at V_{2W}); $H_{IM} = H_{TH} = 0$; $H_{FRX} = H_{FRR} = 1$

AR = 0 dB

AX = 0 dB

$f = 1004\text{ Hz}$; 0 dBm0; A-Law or μ -Law;

In Transmit direction for μ -law an additional gain of 1.94 dB is implemented.

The 0 dBm0 definitions for Receive and Transmit are different.

A 0 dBm0 signal in Transmit direction is equivalent to 206 mVrms [165 mVrms].

(A -Law, [μ -Law]).

A 0 dBm0 signal in Receive direction is equivalent to 118 mVrms.

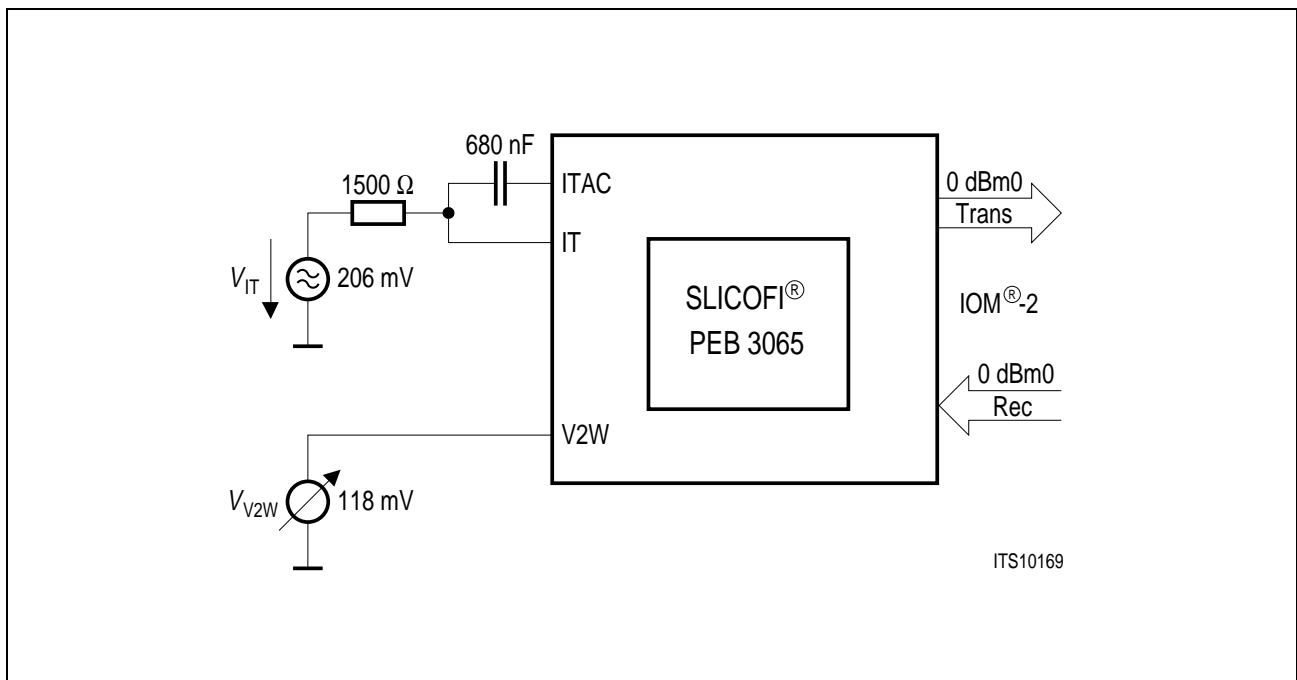

Figure 10

With $V_{IT} = 0\text{ dBm0}|_{\text{SLICOFI}} = -11.51\text{ dBm0}|_{600} = 206\text{ mV}$ for transmit

With $V_{V2W} = 0\text{ dBm0}|_{\text{SLICOFI}} = -16.34\text{ dBm0}|_{600} = 118\text{ mV}$ for receive

Transmission Characteristics

Table 14

Parameter	Symbol	Limit Values			Unit	Test Condition
		min.	typ.	max.		
Gain absolute						
transmit	G_X	- 0.20	± 0.05	0.20	dB	
receive	G_R	- 0.20	± 0.05	0.20	dB	
IMAN-Loop	G_{IMAN}	- 0.5	± 0.1	0.5	dB	adding to - 7.2 dB Loop gain
TTX-injection	G_{TTX}	- 0.7	± 0.3	0.7	dB	
Total Harmonic distortion						
transmit	THD_T		- 56	- 48	dB	at 0 dBm0; $f = 1$ kHz; 2 nd , 3 rd order
receive	THD_R		- 56	- 48	dB	at 0 dBm0; $f = 1$ kHz; 2 nd , 3 rd order
Ringing injection	THD_{Rng}		- 35	- 34	dB	$f = 16.3-70$ Hz
TTX injection	THD_{TTX}		- 60	- 40	dB	$f = 12$ kHz and 16 kHz
Idle channel noise						
transmit	N_{TP}		- 69	- 67	dBm0p	Teletax countries, burst off A-law, psophometric: $V_{IN} = 0$ V
	N_{TTX_TP}		- 65	- 60	dBm0p	Teletax burst on A-law, psophometric: $V_{IN} = 0$ V
	N_{G_TP}		- 58	- 53	dBm0p	AX = 30 dB Teletax countries, burst off A-law, psophometric: $V_{IN} = 0$ V
receive	N_{RP}		- 88	- 81	dBm0p	Teletax countries, burst off A-law, psophometric idle code +0
	N_{TTX_RP}		- 87	- 80	dBm0p	Teletax burst on A-law, psophometric idle code +0

Transmission Characteristics

8.1 Frequency Response

Receive: reference frequency 1 kHz, signal level 0 dBm0, $H_{FRR} = 1$

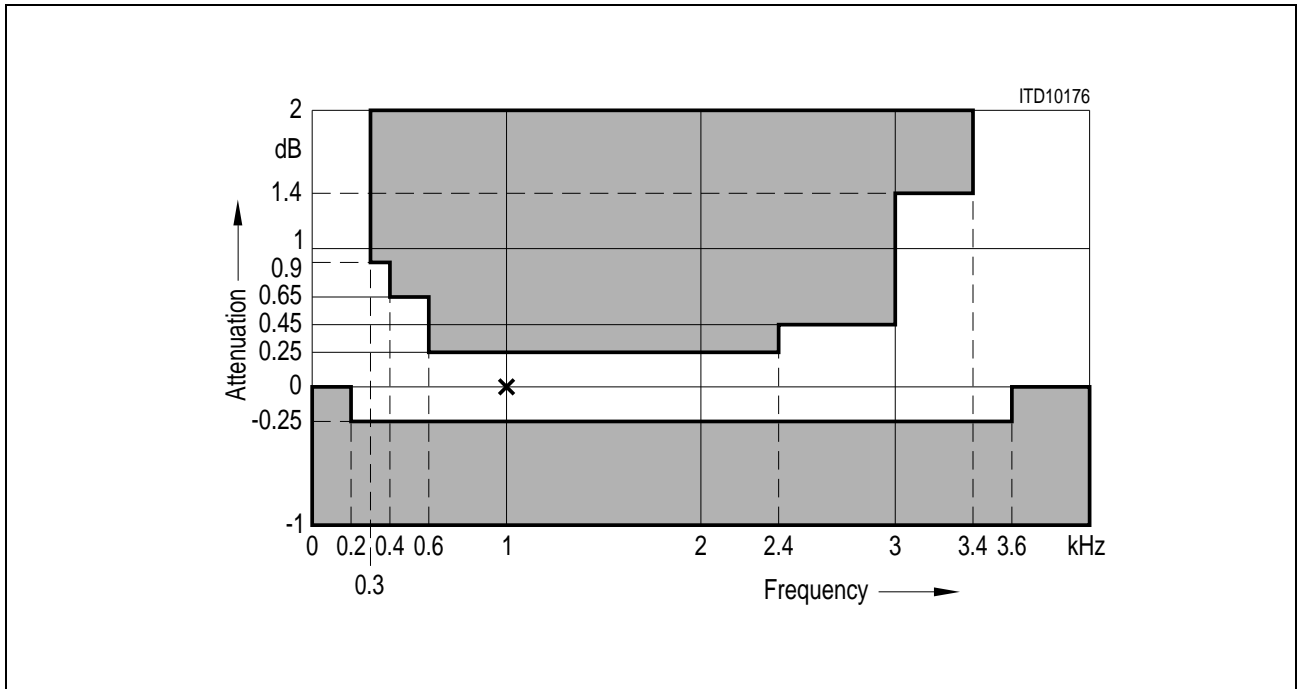

Figure 11

Transmit: reference frequency 1 kHz, signal level 0 dBm0, $H_{FRX} = 1$

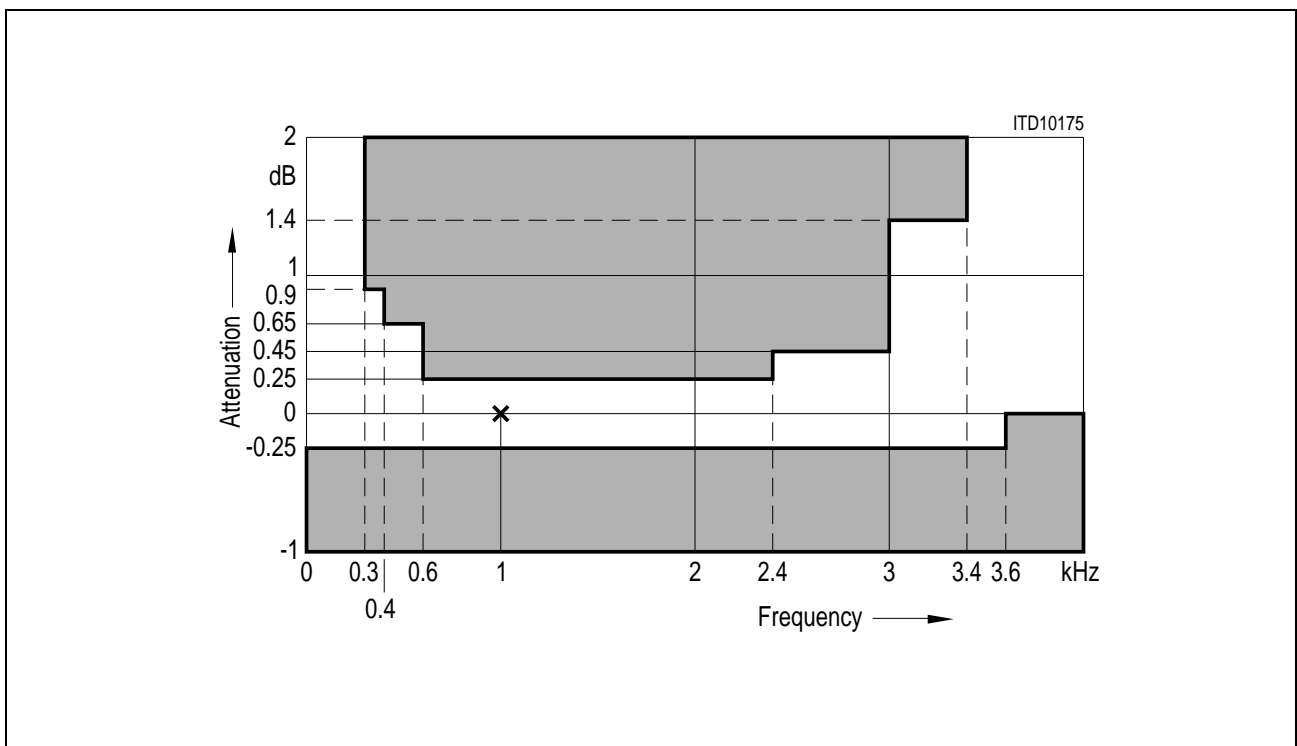

Figure 12

Transmission Characteristics

8.2 Group Delay

Maximum delays when the SLICOFI is operating with $H_{TH} = H_{IM} = 0$ and $H_{FRR} = H_{FRX} = 1$ including delay through A/D- and D/A converters. Specific filter programming may cause additional group delays.

Group Delay deviations stay within the limits in the figures below.

Group Delay absolute values: Signal level 0 dBm0

Table 15

Parameter	Symbol	Limit Values			Unit	Test Condition
		min.	typ.	max.		
Transmit delay	D_{XA}	250	312	375	μs	$f_{\text{Test}} @ T_{\text{Gmin}}$
Receive delay	D_{RA}	250	312	375	μs	$f_{\text{Test}} @ T_{\text{Gmin}}$
Digital loop back	D_{RX}			630	μs	$f_{\text{Test}} @ T_{\text{Gmin}}$

Group Delay Distortion receive and transmit: Signal level 0 dBm0, $f_{\text{Test}} @ T_{\text{Gmin}}$

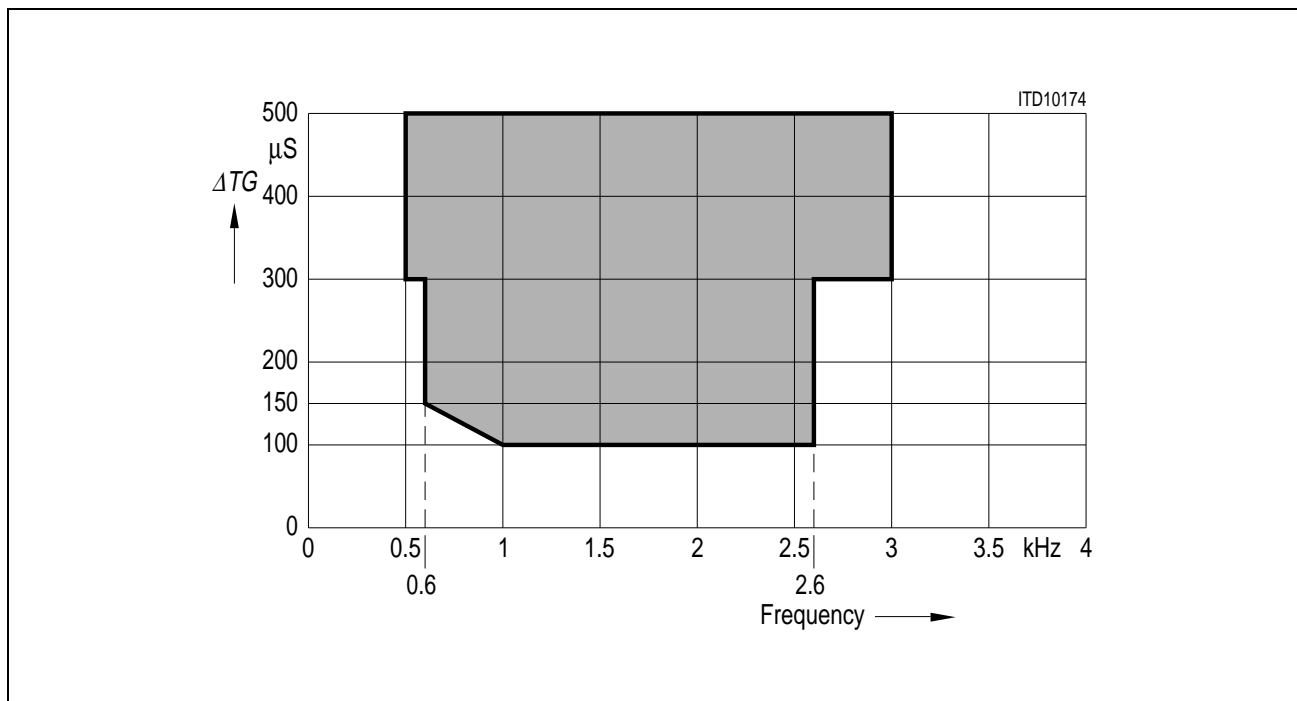

8.3 Out-of-Band Signals at Analog Output (receive)

With a 0 dBm0 sine wave with frequency f (300 Hz to 3.4 kHz) applied to the digital input, the level of any resulting out-of-band signal at the analog output will stay at least X dB below a 0 dBm0, 1 kHz sine wave reference signal at the analog output

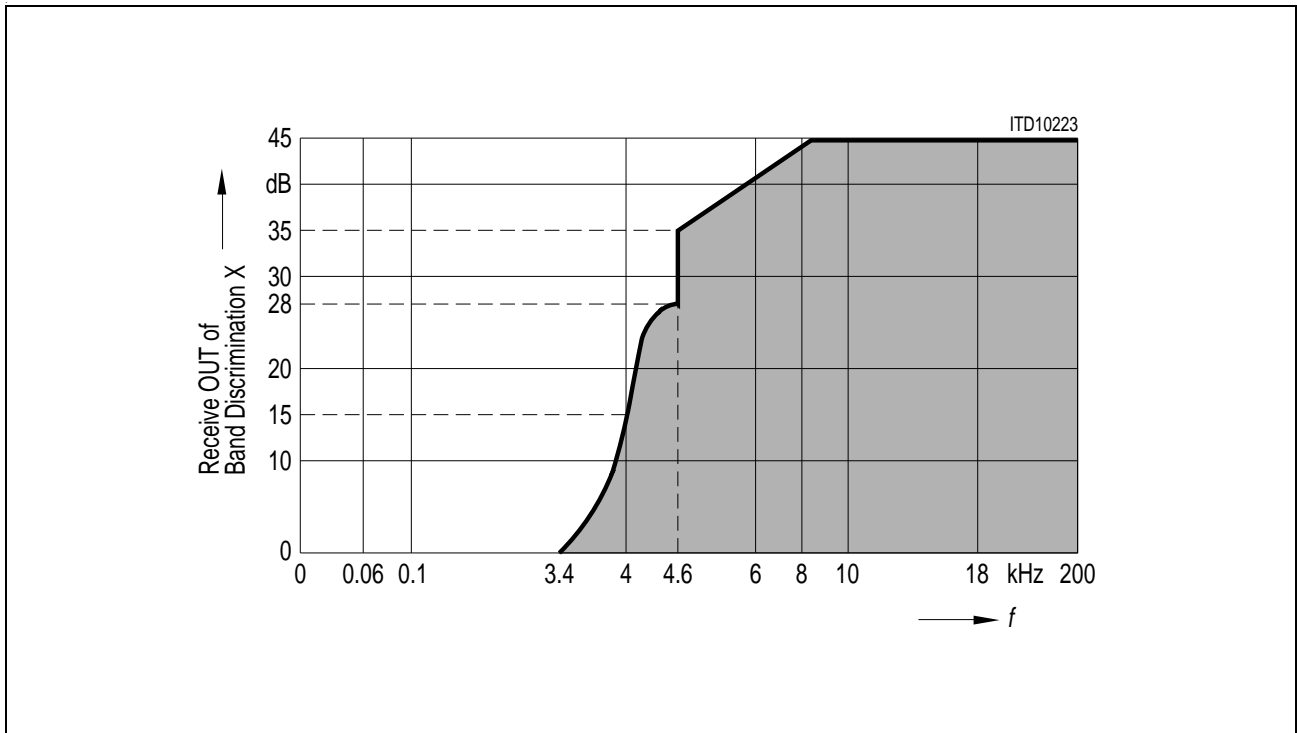

Figure 13

$$3.4 \dots 4.6 \text{ kHz: } X = -14 \left(\sin \left(\left(\pi \frac{4000 - f}{1200} \right) - 1 \right) \right)$$

8.4 Out-of-Band Signals at Analog Input (transmit)

With a 0 dBm0 out-of-band sine wave signal with frequency f (< 100 Hz or 3.4 kHz to 100 kHz) applied to the analog input, the level of any resulting frequency component at the digital output will stay at least X dB below a 0 dBm0, 1 kHz sine wave reference signal at the analog input.¹⁾

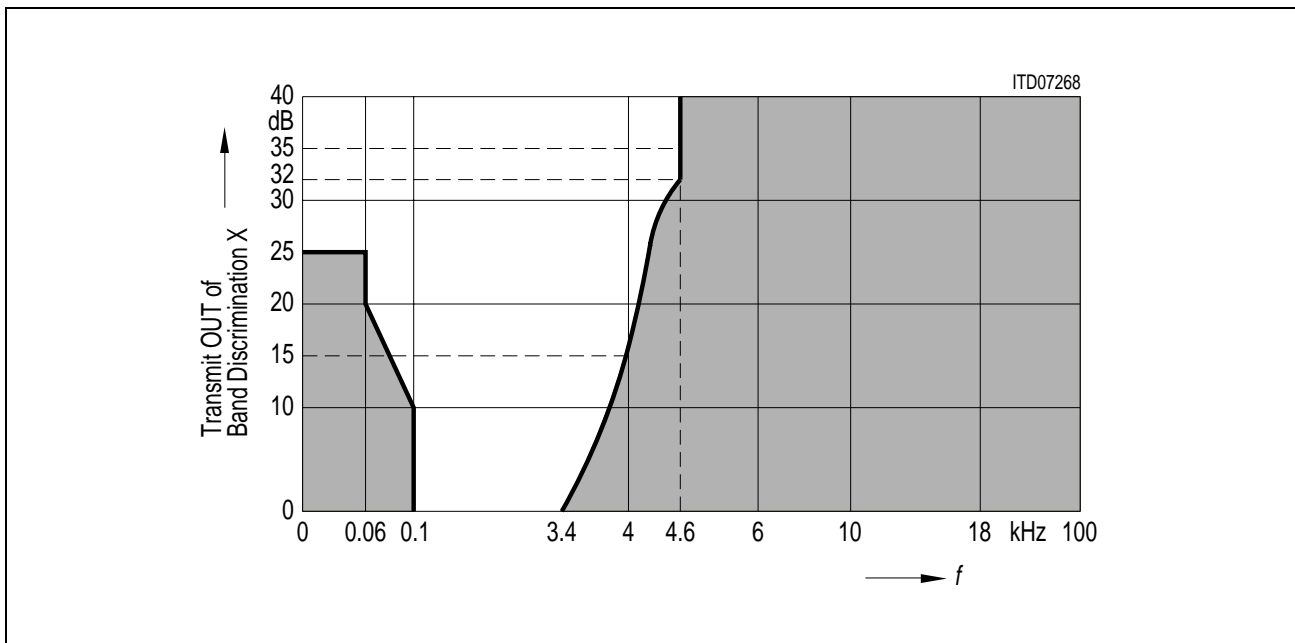

Figure 14

$$3.4 \dots 4.0 \text{ kHz: } X = -14 \left(\sin \left(\pi \frac{4000 - f}{1200} \right) - 1 \right)$$

$$4.0 \dots 4.6 \text{ kHz: } X = -18 \left(\sin \left(\pi \frac{4000 - f}{1200} \right) - \frac{7}{9} \right)$$

¹⁾ Poles at $12 \text{ kHz} \pm 150 \text{ Hz}$ respectively $16 \text{ kHz} \pm 150 \text{ Hz}$ and harmonics will be provided.

8.5 Overload Compression

Transmit: measured with sine wave $f = 1004$ Hz.

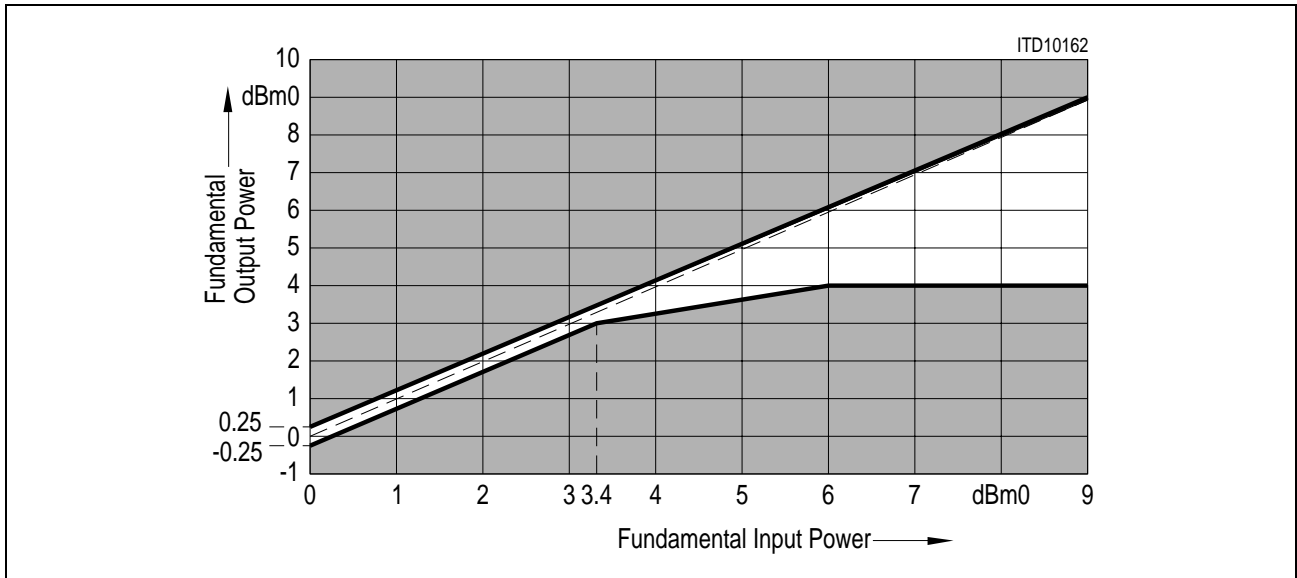

Figure 15

Transmission Characteristics

8.6 Gain Tracking (receive or transmit)

The gain deviations stay within the limits in the figures below.

Receive: measured with sine wave $f = 1004$ Hz
reference level is -10 dBm0.
 $A_R = 6$ dB

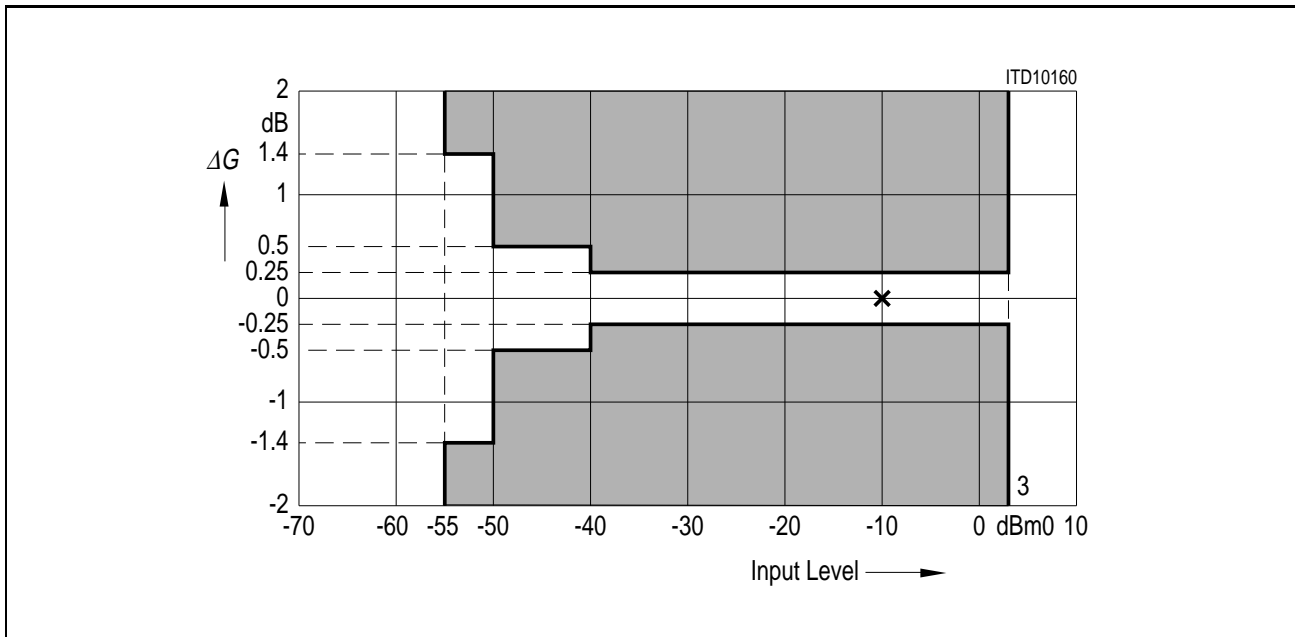

Figure 16

Transmit: measured with sine wave $f = 1004$ Hz
reference level is -10 dBm0.
 $A_X = 0$ dB

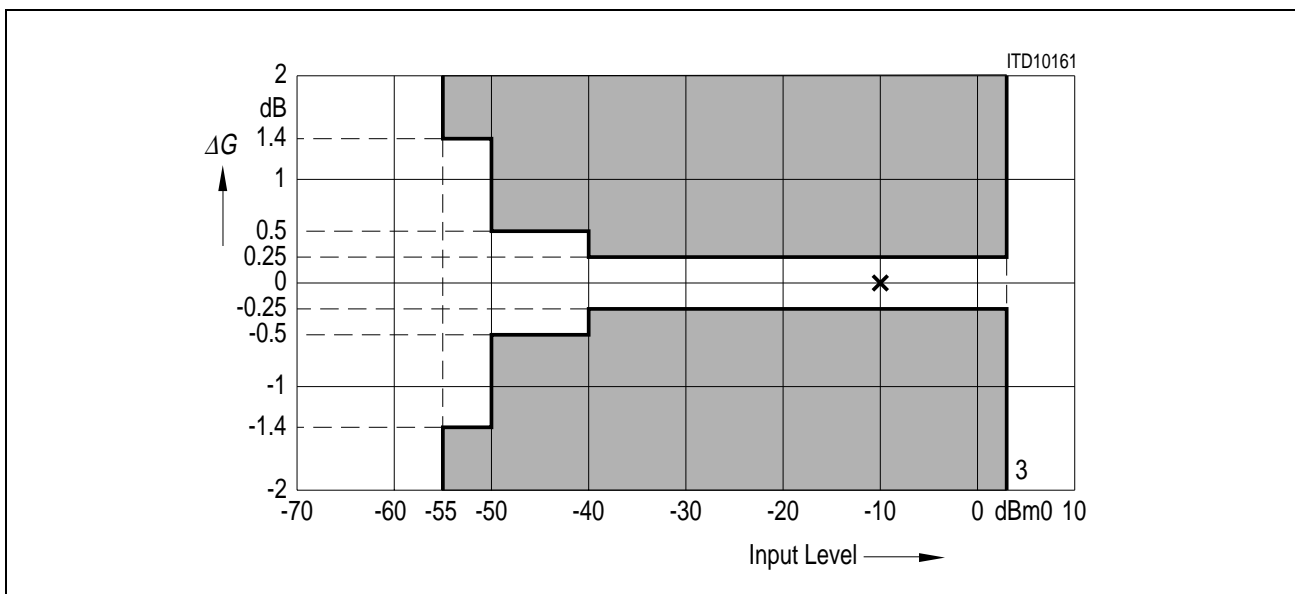

Figure 17

Transmission Characteristics

8.7 Total Distortion

The signal to distortion ratio exceeds the limits in the following figure:

Receive: measured with sine wave $f = 1004$ Hz (C-message weighted for μ -law, psophometrically weighted for A-law).

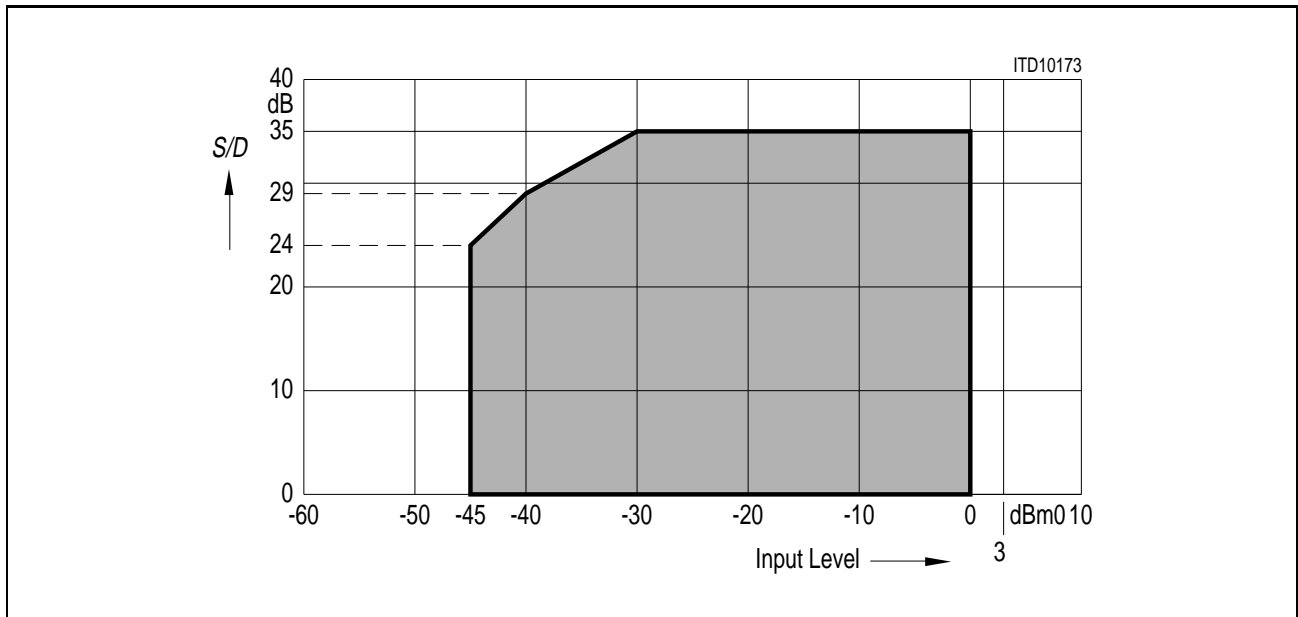

Figure 18

$$\Sigma(A_{R1} + A_{R2}) = 7 \text{ dB}$$

Table 16

Parameter	Symbol	Limit Values			Unit	Test Condition
		min.	typ.	max.		
Signal to Distortion at full attenuation	SD_{att_R}		- 13	- 7	dB	Signal S = - 40 dB $A_R = 30$ dB

Transmit: measured with sine wave $f = 1004$ Hz (C-message weighted for μ -law, psophometrically weighted for A-law).

Transmission Characteristics

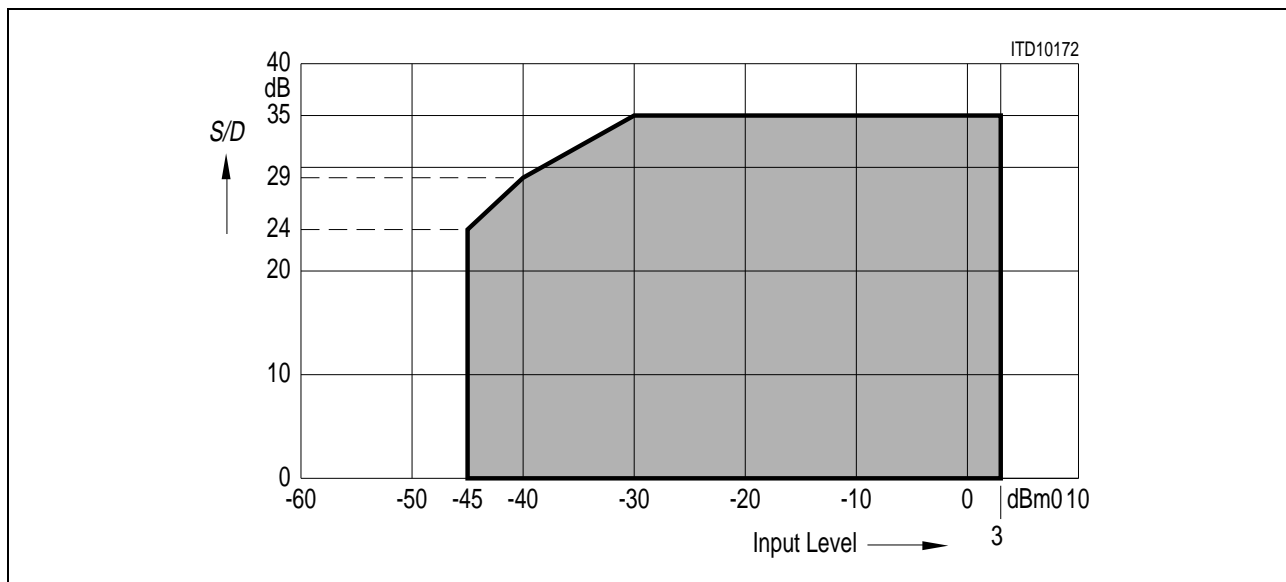

Figure 19

$A_x = -7 \text{ dB}$

Table 17

Parameter	Symbol	Limit Values			Unit	Test Condition
		min.	typ.	max.		
Signal to Distortion at full gain	SD_{att_T}		- 17	- 12	dB	Signal S = - 40 dB $A_x = - 30 \text{ dB}$
Signal to Distortion in IMAN Loop	SD_{IMAN}		- 39	- 30	dB	Signal S = - 45 dB

8.8 Transhybrid Loss

The quality of Transhybrid-Balancing is very sensitive to deviations in gain and group delay – deviations inherent to the SLICOFI A/D- and D/A-converters as well as to all external components used on a line card (HV-SLIC).

Measurement of SLICOFI Transhybrid-Loss: A 0 dBm0 sine wave signal with a frequency in the range between 300-3400 Hz is applied to the digital input. The resulting analog output signal at pin V_{2W} is connected to the pin ITAC via a 1 le filters FRR, A_R , FRX, A_X and IM are disabled, the balancing filter TH is enabled with coefficients optimized for this configuration ($V_{2W} = ITAC$).

The resulting echo measured at the digital output is at least X dB below the level of the digital input signal as shown in the table below

Table 18

	COP-write	Coefficients								
TH-Filter Part 1	00 _H	00	80	80	18	00	08	00	88	
TH-Filter Part 2	01 _H	08	00	AF	84	04	AC	2B	90	
TH-Filter Part 3	02 _H	DA	AB	B3	22	DB	37	88	00	

Table 19

Parameter	Symbol	Limit Values		Unit	Test Condition
		min.	typ.		
Transhybrid Loss at 500 Hz	THL ₅₀₀	33	50	dB	
Transhybrid Loss at 2500 Hz	THL ₂₅₀₀	29	44	dB	
Transhybrid Loss at 3000 Hz	THL ₃₀₀₀	27	42	dB	

9 Electrical Characteristics

9.1 Absolute Maximum Ratings

Table 20

Parameter	Symbol	Limit Values		Unit	Test Condition
		min.	max.		
V_{DDA} referred to GNDA		-0.3	7.0	V	
V_{DDD} referred to GNDD		-0.3	7.0	V	
V_{SS} referred to GNDA		-5.5	0.3	V	
GNDA with respect to GNDD		-0.3	0.3	V	
V_{DDA} with respect to V_{DDD}		-0.3	0.3	V	
$V_{LINE1,2}$ referred to GND		-75	75	V	
Analog input and output voltage referred to $V_{DDA} = 5\text{ V}$; ($V_{SS} = -5\text{ V}$)		-10.3	0.3	V	
referred to $V_{SS} = -5\text{ V}$; ($V_{DDA} = 5\text{ V}$)		-0.3	10.3	V	
All digital input voltages referred to GNDD = 0 V; ($V_{DDD} = 5\text{ V}$)		-0.3	5.3	V	
referred to $V_{DDD} = 5\text{ V}$; (GNDD = 0 V)		-5.3	0.3	V	
DC input and output current at any input or output pin (free from latch -up)			100	mA	
Storage temperature	T_{STG}	-65	125	°C	
Ambient temperature under bias	T_A	-10	80	°C	
Power dissipation	P_D		1	W	
ESD-integrity (according MIL-Std 883D, method 3015.7) ¹⁾	V_{ESD}	1000		V	

¹⁾ All Pins except V_{LINE1} and V_{LINE2} (11, 12); for these Pins $V_{ESD} < 500\text{ V}$ due to process limitation

Note: Stresses above those listed under Absolute Maximum Ratings may cause permanent damage to the device.

Functional operation under these conditions is not implied.

Exposure to conditions beyond those indicated in the recommended operational conditions of this specification may effect device reliability.

Electrical Characteristics

9.1.1 Operating Range

$T_A = -40$ to 85 °C; $V_{DD} = V_{DDD} = V_{DDA} = 5$ V \pm 5%;
 $V_{SS} = -5$ V \pm 5%; $GNDD = GNDA = 0$ V

Table 21

Parameter	Symbol	Limit Values			Unit	Test Condition
		min.	typ.	max.		
V_{DD} supply current ¹⁾						
Power Denial	IDD_{PDen}		4	6	mA	
Power Down	IDD_{PDown}		11	15	mA	
Active	IDD_{Act}		21	30	mA	
Active with TTX	IDD_{TTX}		25	34	mA	
Ringing	IDD_{Rng}		11	15	mA	
V_{SS} supply current ¹⁾						
Power Denial	ISS_{PDen}		1	2	mA	
Power Down	ISS_{PDown}		3,5	6	mA	
Active	ISS_{Act}		4,5	7	mA	
Active with TTX	ISS_{TTX}		7	10	mA	
Ringing	ISS_{Rng}		3.5	6	mA	
Power supply rejection-ratio	PSRR					ripple: 1 kHz, 70 mVrms
receive V_{DD}		56	70		dB	at V_{2W}
receive V_{SS}		56	65		dB	at V_{2W}
transmit V_{DD}		40	70		dB	at IOM-2
transmit V_{SS}		40	50		dB	at IOM-2
Power dissipation ¹⁾						
Power Denial	PDen		25	42	mW	
Power Down	PDown		73	110	mW	
Active	Act		128	195	mW	
Active with TTX	TTX		160	231	mW	
Ringing	Rng		73	110	mW	

¹⁾ Power dissipation and supply currents are target values.

Electrical Characteristics

9.2 Digital Interface

$T_A = -40$ to 85 °C; $V_{DD} = V_{DDD} = V_{DDA} = 5$ V \pm 5%;
 $V_{SS} = -5$ V \pm 5%; $GNDD = GNDA = 0$ V

Table 22

Parameter	Symbol	Limit Values		Unit	Test condition
		min	max.		
For all input pins (including IO-Pins):					
Low-input pos.-going	V_{T+}	- 0,3	3.15	V	see figure below
Low-input neg.-going	V_{T-}	1.35	V_{DD} + 0,3	V	see figure below
Low-input Hysteresis	V_H	0.5		V	$V_H = V_{T+} - V_{T-}$
Input leakage current	I_{IL}	- 1	1	μ A	$- 0.3 \leq V_{in} \leq V_{DD}$
Spike rejection for RESET (pin 36)	t_{rej}	50	200	ns	
Ternary Inputs: ID-L, ID-M (pins 31, 32)					
High level	V_{IHID}	2.0		V	
Zero level	V_{IMID}	- 0.8	0.8	V	
Low level	V_{ILID}		- 2.0	V	
For all output pins except DU (Pin 6; including IO-Pins):					
Low-output voltage	V_{OL}		0.45	V	$I_O = - 2$ mA (typ. at $I_O = - 3.5$ mA)
High-output voltage for DU-pin (Pin 6)	V_{OH}	3.5		V	$I_O = 400$ μ A
Low-output voltage	V_{OLDU}		0.45	V	$I_O = - 4$ mA (typ. at $I_O = - 7$ mA)
High-output voltage	V_{OHDU}	3.5		V	$I_O = 400$ μ A

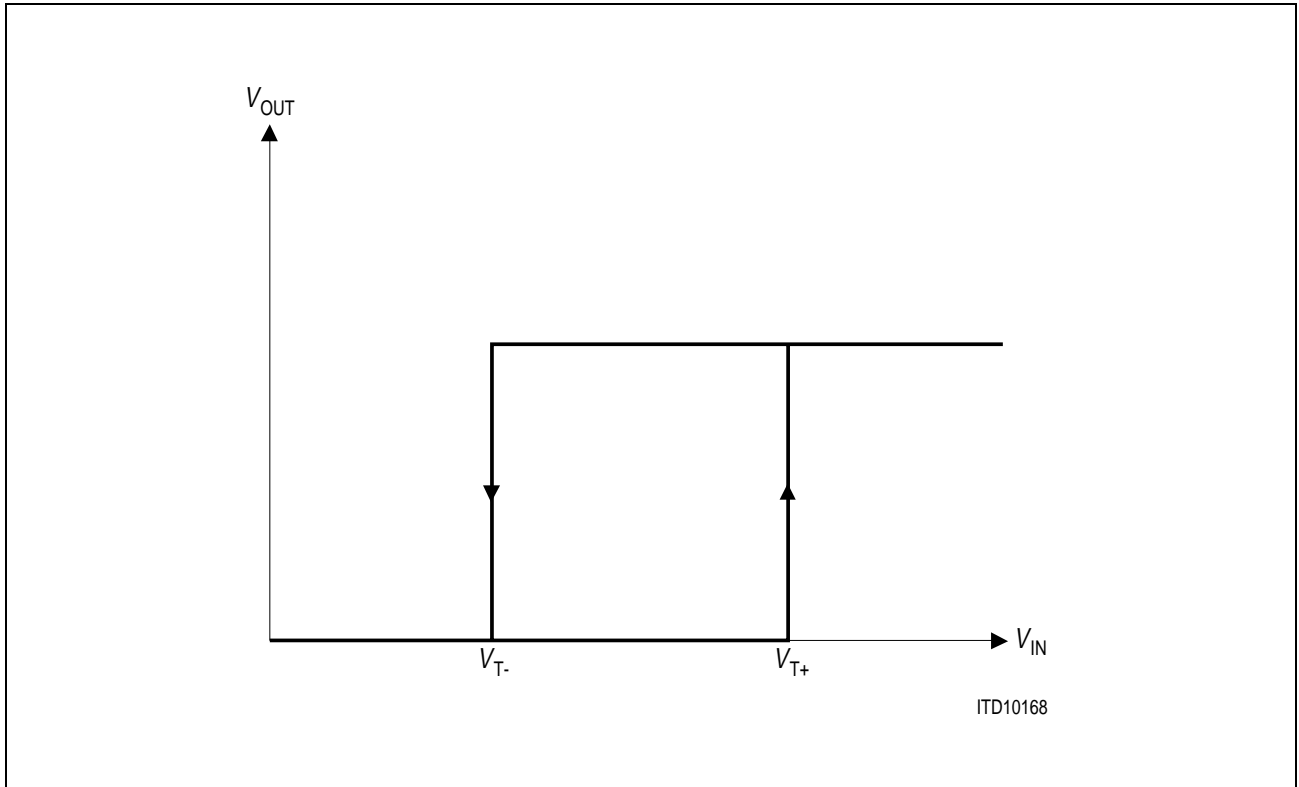

Figure 20

Electrical Characteristics

9.3 DC-Feeding

9.3.1 DC-Feeding ($T_A = 0$ to 70 °C)

$T_A = -0$ to 70 °C; $V_{DD} = V_{DDD} = V_{DDA} = 5$ V \pm 5%;
 $V_{SS} = -5$ V \pm 5%; $GNDD = GNDA = 0$ V

Table 23

Parameter	Symbol	Limit Values			Unit	Test condition
		min.	typ.	max.		
"Line Current" Measurement: Transmit	$V_{IT\ offset}$	- 25		25	mV	direct/reverse polarity
	$V_{IT\ gain}$	0.94		1.06		$f < 50$ Hz, direct polarity
	$V_{IT\ gain}$	- 1.06		- 0.94		$f < 50$ Hz, reverse polarity
	$V_{IT\ THD^-}$	40	50		dB	direct/reverse polarity
"Line Voltage" Feeding: Receive	$V_{2W\ offset}$	- 25		25	mV	normal battery, $f = 300$ Hz
	$V_{2W\ gain}$	0.94		1.06		normal battery, $f = 300$ Hz
	$V_{2W\ THD}$	40	50		dB	normal battery
Receive Boosted	$V_{2W\ offset}$	- 40		40	mV	boosted battery, $f = 300$ Hz
	$V_{2W\ gain}$	1.5	1.6	1.7		boosted battery, $f = 300$ Hz
	$V_{2W\ THD}$	40	50		dB	boosted battery

9.3.2 DC-Feeding ($T_A = -40$ to 85 °C)

$T_A = -40$ to 85 °C; $V_{DD} = V_{DDD} = V_{DDA} = 5$ V \pm 5%;
 $V_{SS} = -5$ V \pm 5%; $GNDD = GNDA = 0$ V

Table 24

Parameter	Symbol	Limit Values			Unit	Test Condition
		min.	typ.	max.		
"Line Current" Measurement: Transmit	$V_{IT\ offset}$	- 30		30	mV	direct/reverse polarity
	$V_{IT\ gain}$	0.94		1.06		$f < 50$ Hz, direct polarity
	$V_{IT\ gain}$	- 1.06		- 0.94		$f < 50$ Hz, reverse polarity
	$V_{IT\ THD^-}$	40	50		dB	direct/reverse polarity

Electrical Characteristics

Table 24 (cont'd)

Parameter	Symbol	Limit Values			Unit	Test Condition
		min.	typ.	max.		
"Line Voltage" Feeding: Receive	$V_{2W\ offset}$	-30		30	mV	normal battery, $f = 300\text{ Hz}$
	$V_{2W\ gain}$	0.927		1.073		normal battery, $f = 300\text{ Hz}$
	$V_{2W\ THD}$	40	50		dB	normal battery
Receive Boosted	$V_{2W\ offset}$	-48		48	mV	boosted battery, $f = 300\text{ Hz}$
	$V_{2W\ gain}$	1.48	1.6	1.72		boosted battery, $f = 300\text{ Hz}$
	$V_{2W\ THD}$	40	50		dB	boosted battery

9.4 HV-SLIC Interface

$T_A = -40\text{ to }85\text{ }^\circ\text{C}$; $V_{DD} = V_{DDD} = V_{DDA} = 5\text{ V} \pm 5\%$;
 $V_{SS} = -5\text{ V} \pm 5\%$; $GNDD = GNDA = 0\text{ V}$

Table 25

Parameter	Symbol	Limit Values			Unit	Test Condition/Result
		min.	typ.	max.		
Ground Key Detection at Pin IL	V_{ILLo}	-217		217	mV	GNK = 0
	V_{ILHi}	293		-293	mV	GNK = 1
Half Battery Information at Pin V_{2W}	V_{V2WLo}			-1.65	V	$V_{BIM} = -3\text{ V}$ VB/2 = 0
	V_{V2WHi}	-1.35			V	VB/2 = 1
PDN-Pin max. R_{on}	R_{on}		90	250		in Active-Mode to GND

Electrical Characteristics

Table 25 (cont'd)

Parameter	Symbol	Limit Values			Unit	Test Condition/Result
		min.	typ.	max.		
Output voltage: HV-SLIC-Interface Pins 9, 10 (C1, C2)						
High level	V_{OHV}	2.5			V	$I_{out} < 10$
Zero level	V_{OMHV}	- 0.8		0.8	V	$I_{out} < 10$
Low level	V_{OLHV}			- 2.5	V	$I_{out} < 10$
Current drained from pin 9 (C1) in all 3 states	I_{OTLo}			320	μA	TEMPA = 0
	I_{OTHi}	480			μA	TEMPA = 1
External Indication						measured at IOM-2 without DC $V_{LINE} = 0 V$ without DC $V_{LINE} = 6 V$ with DC = 30 V $V_{LINE}^{1)} = 6 V$
	V_{EXT_off}	- 200		200	mV	
	V_{EXT_0}	0.5		1.3	V	
	V_{EXT_6}	0.3		1.5	V	

1) $V_{LINE} = V_{LINE1} - V_{LINE2}$

9.5 IOM[®]-2 Interface Timing

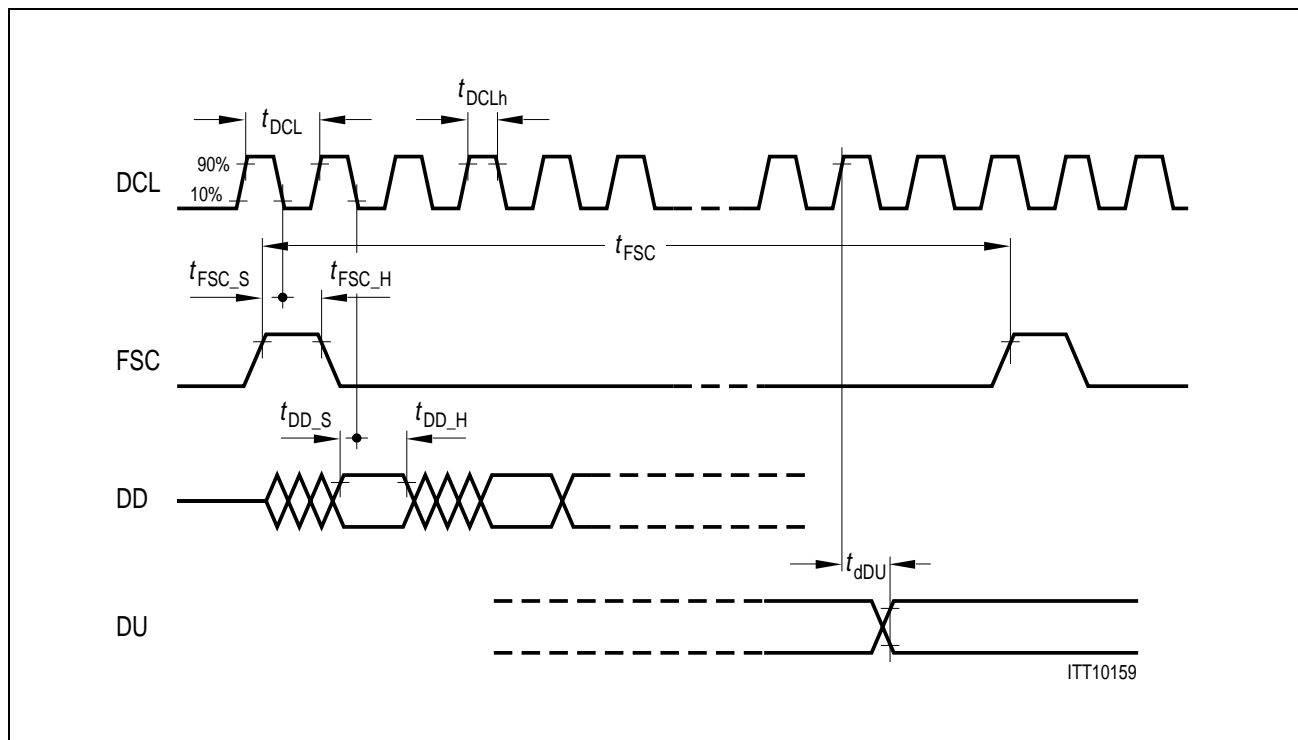

Figure 21

Electrical Characteristics

Table 26 Switching Characteristics

Parameter	Symbol	Limit Values			Unit
		min.	typ.	max.	
Period DCL "slow" mode ¹⁾	t_{DCL}		1/2048		kHz
Period DCL "fast" mode ²⁾	t_{DCL}		1/4096		kHz
DCL Duty Cycle	t_{DCLh}	40		60	%
Period FSC	t_{FSC}		125		μ s
FSC set-up time	t_{FSC_S}	70	t_{DCLh}		ns
FSC hold time	t_{FSC_H}	40			ns
DD data in set-up time	t_{DD_S}	20			ns
DD data in hold time	t_{DD_H}	50			ns
DU data out delay (intrinsic)	$t_{dDUintr.}$		40	70	ns
DU data out delay	t_{dDU}		150 ³⁾	250	ns

1) DCL = 2048 kHz: $t_{FSC} = 256 \times t_{DCL}$

2) DCL = 4096 kHz: $t_{FSC} = 512 \times t_{DCL}$

3) Depending on Pull up resistor (typical 1...10 k)

9.6 IOM[®]-2 Command/Indication Interface Timing (DCL = 4096 kHz)

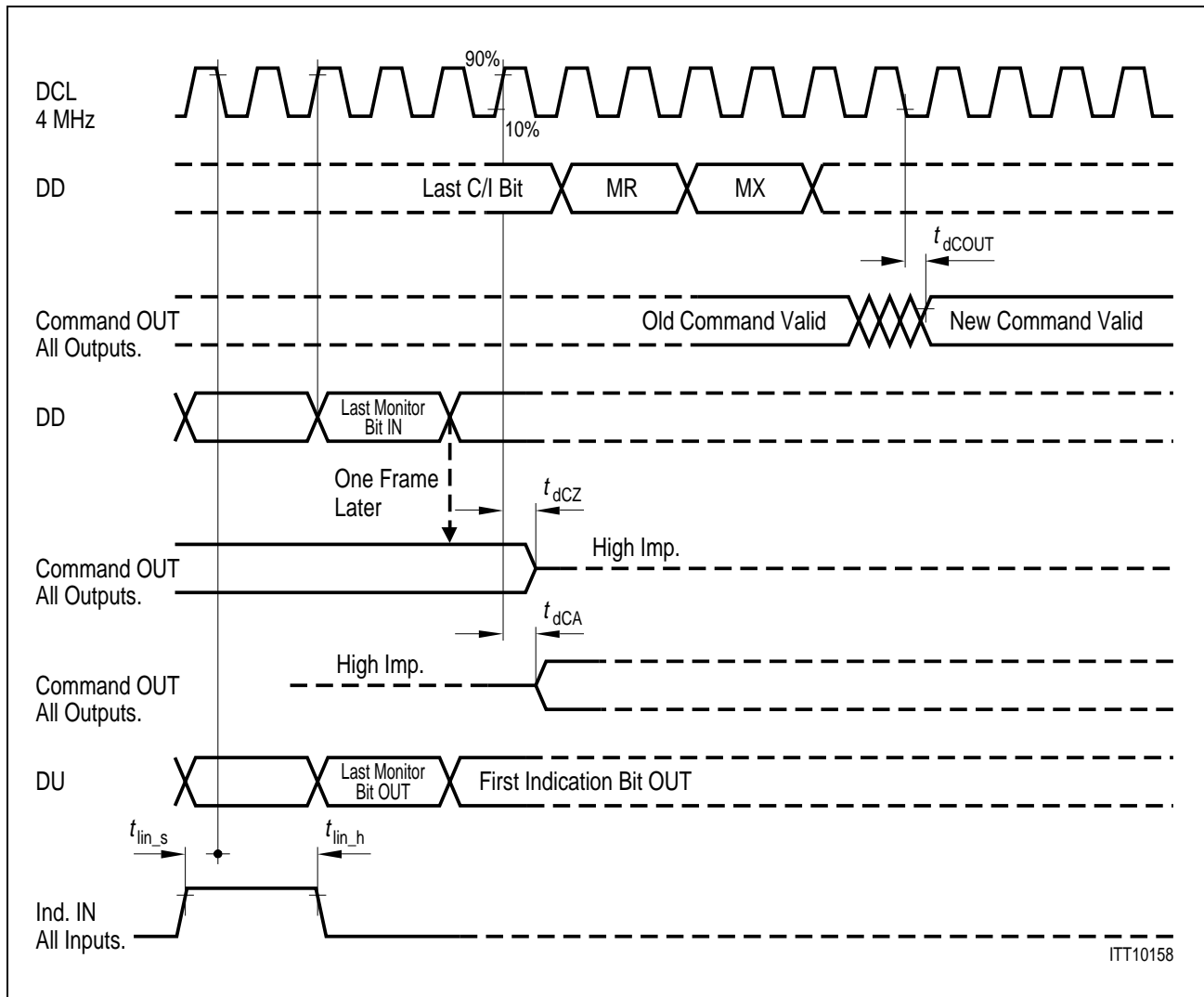

ITT10158

Figure 22

Table 27 Switching Characteristics

Parameter	Symbol	Limit Values			Unit
		min.	typ.	max.	
Command out delay	t_{dCout}			0	ns
Command out high impedance	t_{dCZ}		150	200	ns
Command out active	t_{dCA}		150	200	ns
Indication in set-up time	t_{lin_s}	50			ns
Indication in hold time	t_{lin_h}	200			ns

9.7 IOM[®]-2 Command/Indication Interface Timing (DCL = 2048 kHz)

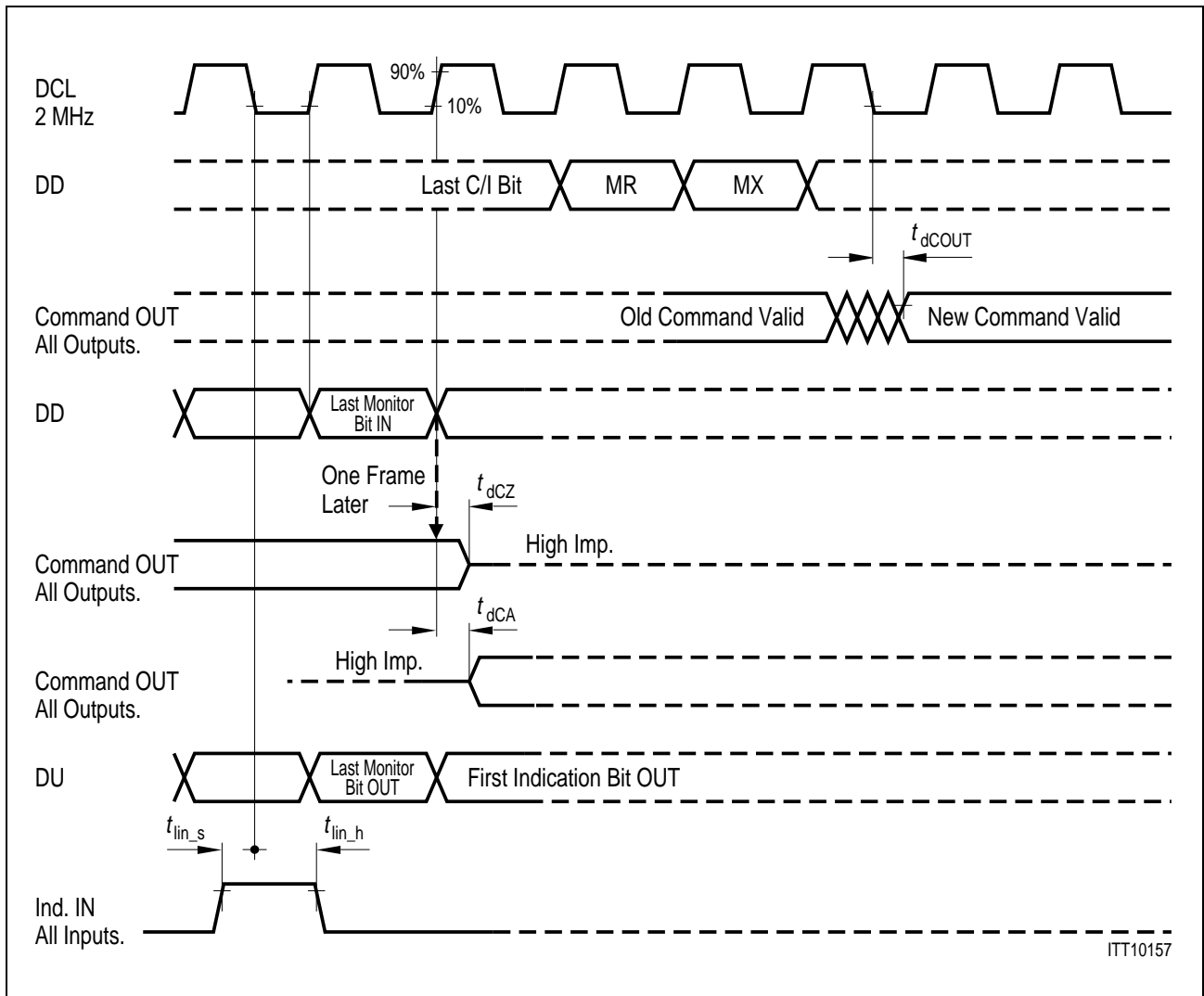

ITT10157

Figure 23

Table 28 Switching Characteristics

Parameter	Symbol	Limit Values			Unit
		min.	typ.	max.	
Command out delay	t_{dCout}			0	ns
Command out high impedance	t_{dCZ}		150	200	ns
Command out active	t_{dCA}		150	200	ns
Indication in set-up time	t_{lin_s}	50			ns
Indication in hold time	t_{lin_h}	200			ns

9.8 External Masterclock

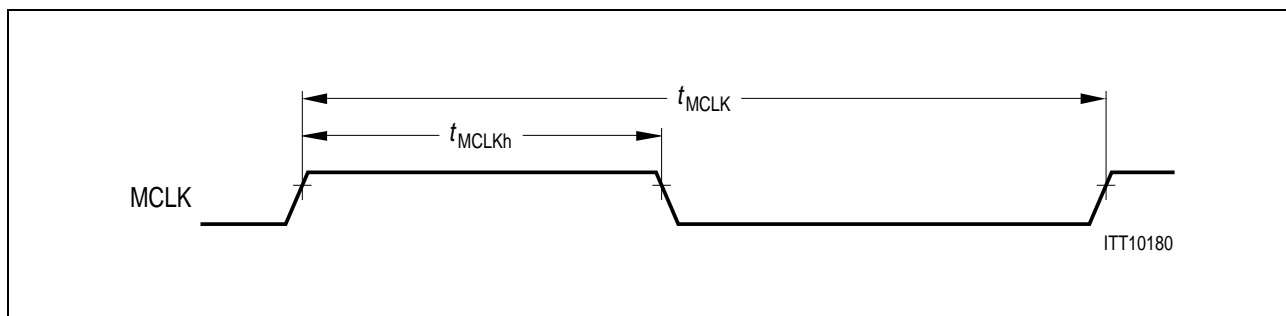

Figure 24

Table 29 Switching Characteristics

Parameter	Symbol	Limit Values			Unit
		min.	typ.	max.	
Period MCLK	t_{MCLK}	40	1/16.384	60	MHz
MCLK Duty Cycle	t_{MCLKh}	40		60	%

10 Appendix

10.1 IOM[®]-2 Interface Monitor Transfer Protocol

Monitor Channel Operation

The monitor channel is used for the transfer of maintenance information between two functional blocks. Using two monitor control bits (MR and MX) per direction, the data are transferred in a complete handshake procedure. The MR and MX bits in the fourth octet (C/I channel) of the IOM2 frame are used for the handshake procedure of the monitor channel

The monitor channel transmission operates on a pseudo-asynchronous basis:

- Data transfer (bits) on the bus is synchronized to Frame Sync FSC
- Data flow (bytes) are asynchronously controlled by the handshake procedure.

For example: Data is placed onto the DD-Monitor-Channel by the Monitor-transmitter of the master device (DD-MX-Bit is activated i.e. set to '0'). This data transfer will be repeated within each frame (125 μs rate) until it is acknowledged by the SLICOFI Monitor-receiver by setting the DU-MR-bit to '0', which is checked by the Monitor-transmitter of the master device. Thus, the data rate is not 8-Kbytes/s.

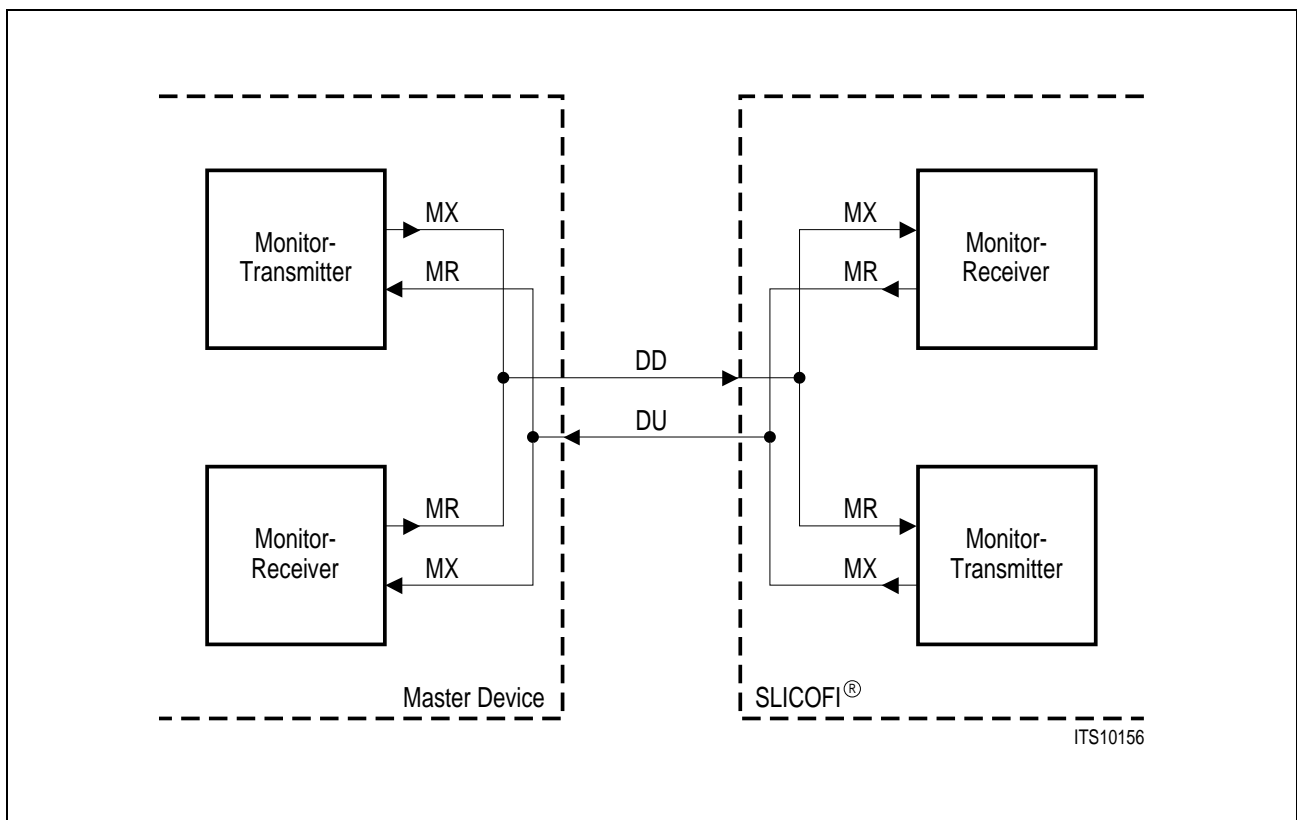

Figure 25

Monitor Handshake Procedure

The monitor channel works in 3 states

- Idle state** A pair of inactive (set to '1') MR- and MX-bits during two or more consecutive frames: End of Message (EOM)
- Sending state** MX-bit is activated (set to '0') by the Monitor-transmitter, together with data-bytes (can be changed) on the Monitor-channel
- Acknowledging** MR-bit is set to active (set to '0') by the Monitor-receiver, together with a data-byte remaining in the Monitor-channel.

A start of transmission is initiated by a Monitor-transmitter in sending out an active MX-bit together with the first byte of data (the address of the receiver) to be transmitted in the Monitor-channel.

This state remains until the addressed Monitor-Receiver acknowledges the received data by sending out an active MR-bit, which means that the data-transmission is repeated each 125 μ s frame (minimum is one repetition). During this time the Monitor-transmitter evaluates the MR-bit.

Flow control, means in the form of transmission delay, can only take place when the transmitters MX and the receivers MR bit are in active state.

Since the receiver is able to receive the monitor data at least twice (in two consecutive frames), it is able to check for data errors. If two different bytes are received the receiver will wait for the receipt of two identical successive bytes (last look function)

A collision resolution mechanism (check if another device is trying to send data during the same time) is implemented in the transmitter. This is done by looking for the inactive ('1') phase of the MX-bit and making a per bit collision check on the transmitted monitor data (check if transmitted '1's are on DU/DD-line; DU/DD-line are open-drain lines).

Any abort leads to a reset of the SLICOFI command stack, the device is ready to receive new commands.

To obtain a maximum speed data transfer, the transmitter anticipates the falling edge of the receivers acknowledgment.

Due to the inherent programming structure, duplex operation is not possible. It is not **allowed** to send any data to the SLICOFI, while transmission is active.

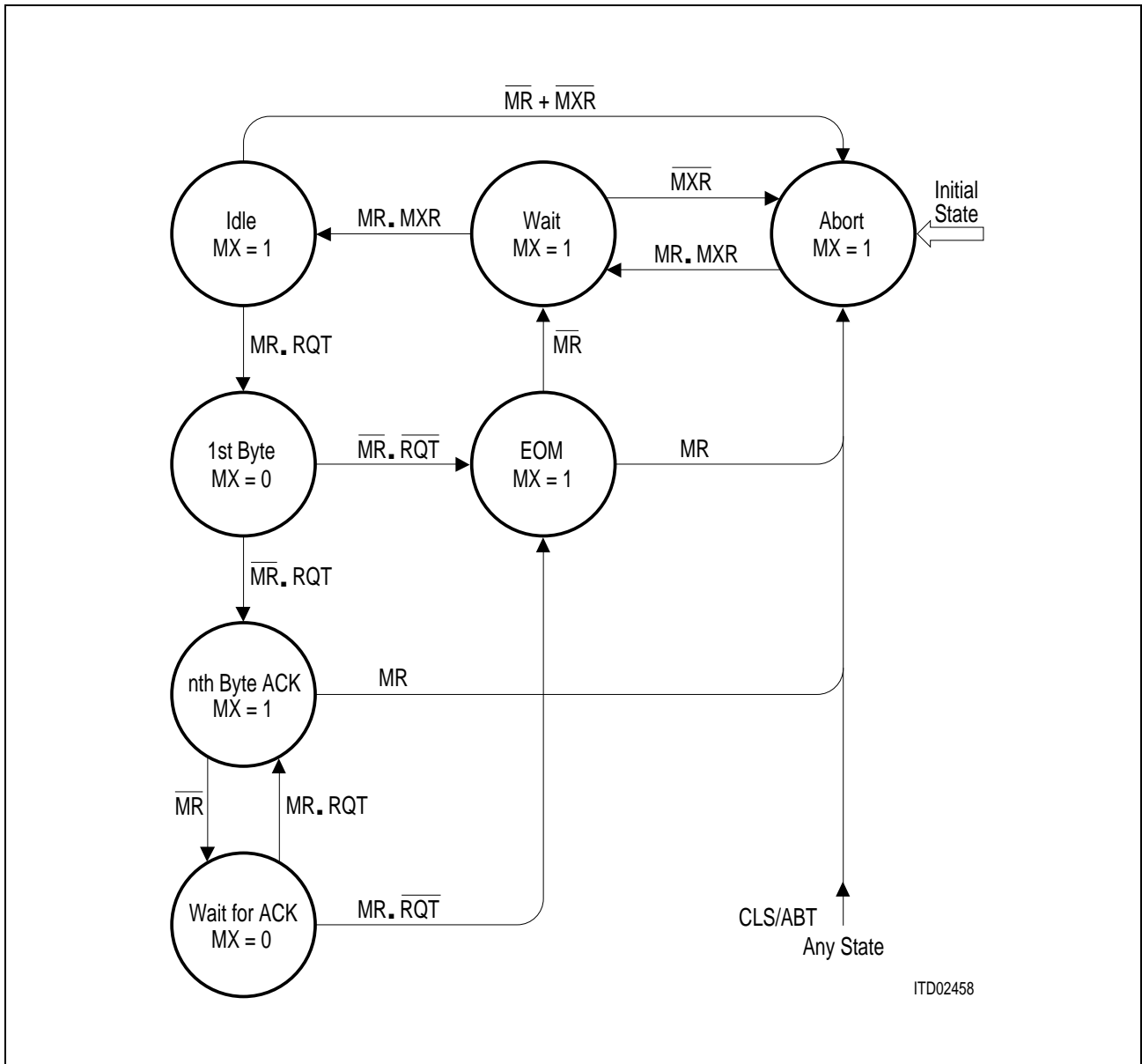

ITD02458

Figure 26 State Diagram of the SLICOFI Monitor Transmitter

- MR ... MR - bit received on DD - line
- MX ... MX - bit calculated and expected on DU - line
- MXR ... MX - bit sampled on DU - line
- CLS ... Collision within the monitor data byte on DU - line
- RQT ... Request for transmission form internal source
- ABT ... Abort request/indication

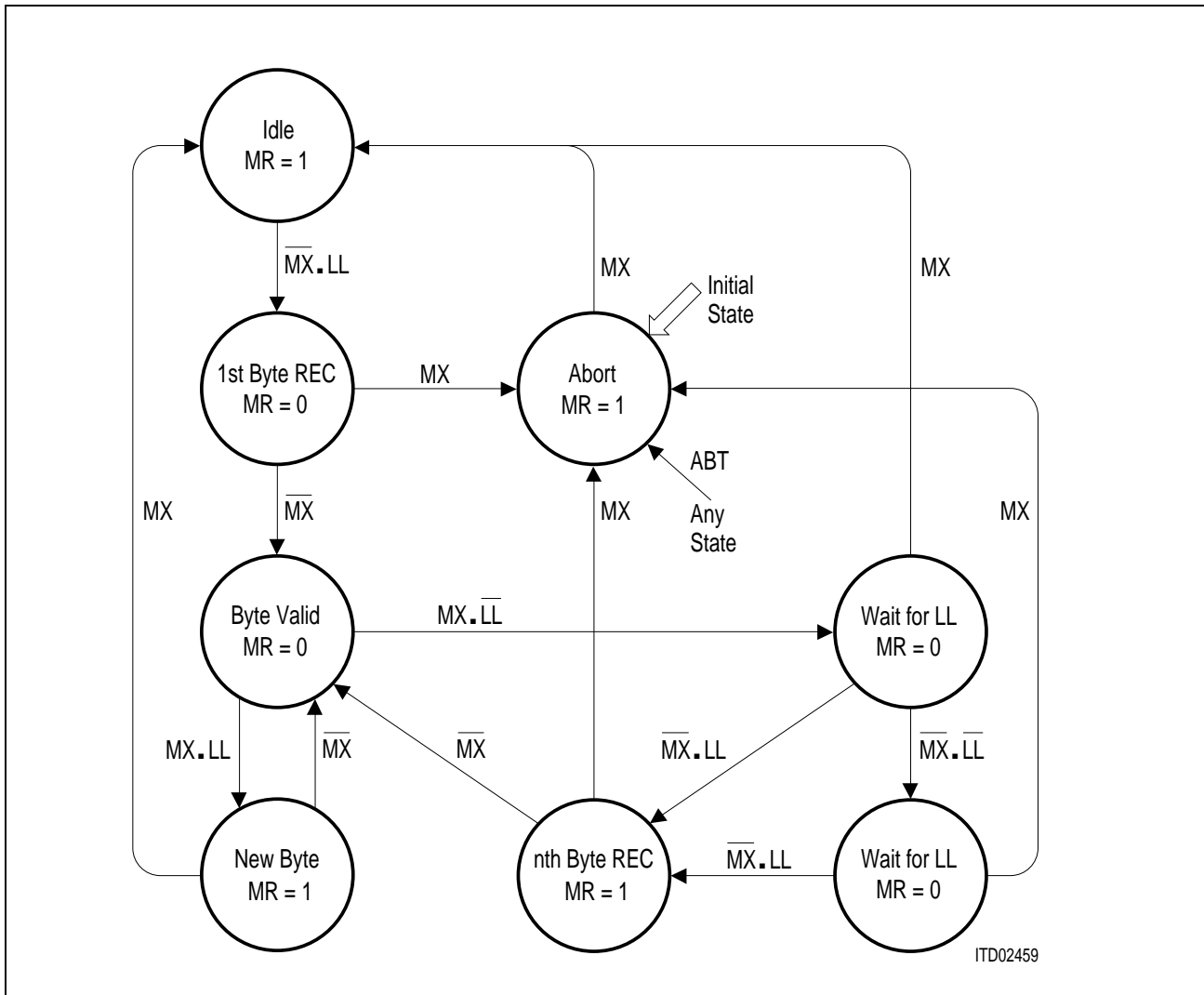

Figure 27 State Diagram of the SLICOFI Monitor Receiver

- MR ... MR - bit calculated and transmitted on DU - line
- MX ... MX - bit received data downstream (DD - line)
- LL ... Last lock of monitor byte received on DD - line
- ABT ... Abort indication to internal source

Monitor Channel Data Structure

The monitor channel is used for the transfer of maintenance information between two functional blocks. By use of two monitor control bits (MR and MX) per direction, the data are transferred in a complete handshake procedure.

Address Byte

Messages to and from the SLICOFI are started with the following byte:

Bit	7	6	5	4	3	2	1	0
	1	0	0	0	0	0	0	1

Thus providing information for only one analog line, the SLICOFI is one device on one IOM-2 time slot. Monitor data for the analog channel is selected by the SLICOFI specific command (SOP, TOP or COP) following.

10.2 Channel Identification Command (CIC)

In order to unambiguously identify different devices by software, a two Byte identification command is defined for analog lines IOM-2 devices. A device requesting the identification of the SLICOFI will send the following 2 byte code:

1	0	0	0	0	0	0	0
0	0	0	0	0	0	0	0

Each device will then respond with its specific identification code. For the SLICOFI this two byte identification code is:

1	0	0	0	CONF			
1	0	0	0	0	0	0	0

CONF an optional 4-bit code indicating the specific hardware environment. A typical application of the CONF code is the differentiation of various types of line circuits that use the same SLICOFI/SLIC hardware within the same system.

For the realization of the Channel Identification Commands on the line card, it needs 3 pins at the SLICOFI. There are two inputs that can handle a ternary code (ID-L and ID-M). One pin is a binary input (ID-H) which is switchable as a digital serial interface of a shift register, to transfer special line card design informations up to 15 bytes into the monitor channel of the IOM-2 interface.

There are two different solutions of the CIC for the SLICOFI to identify the version of the line card.

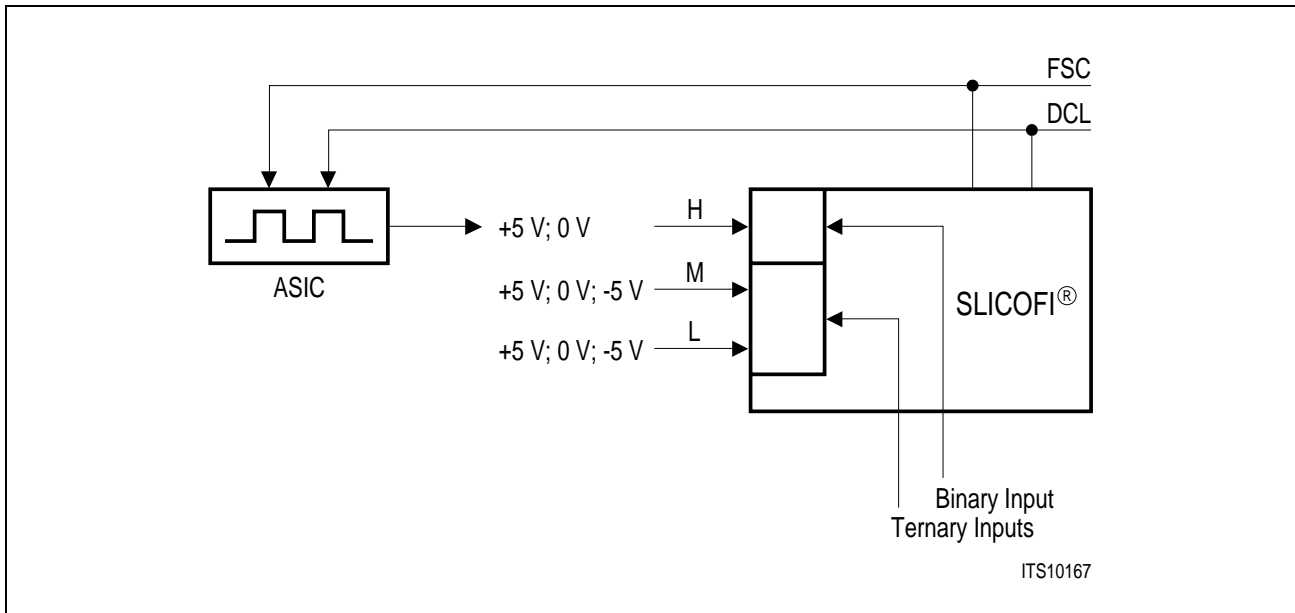

Figure 28

Solution 1 (“Normal” Channel Identification Command):

The input of the 3 pin interface (ID-H, ID-L, ID-M) is transferred to the 4 bit CONF information using the following truth-table:

Table 30

SLICOFI Ports			CONF-inf.
ID-H	ID-M	ID-L	(4 bits)
+5 V	-5 V	-5 V	0 0 0 0
+5 V	-5 V	0 V	0 0 0 1
+5 V	-5 V	+5 V	0 0 1 0
+5 V	0 V	-5 V	0 0 1 1
+5 V	0 V	0 V	0 1 0 0
+5 V	0 V	+5 V	0 1 0 1
+5 V	+5 V	-5 V	0 1 1 0
+5 V	+5 V	0 V	0 1 1 1
0 V	+5 V	0 V	1 0 0 0
0 V	+5 V	-5 V	1 0 0 1
0 V	0 V	+5 V	1 0 1 0
0 V	0 V	0 V	1 0 1 1
0 V	0 V	-5 V	1 1 0 0
0 V	-5 V	+5 V	1 1 0 1
0 V	-5 V	0 V	1 1 1 0
0 V	-5 V	-5 V	1 1 1 1

This is a 16 possible individual line card design information or an address pointer for the system to get more basic information.

The information is read through the IOM-2 monitor channel with the CIC command.

Solution 2 (Extended Channel Identification Command):

The second realization step is that the combination of ports $(M + L) = +5\text{ V}$ changes the input port ID-H to a shift register input.

Table 31

SLICOFI Ports			CONF-inf.
ID-H	ID-M	ID-L	(4 bits)
X	+ 5 V	+ 5 V	1 1 1 1

An external shift register on the line card transmits up to 15 bytes of special HW + FW line card design information (TCR4 - TCR18).

The information is read through the IOM2 monitor channel with the TOP Command. The LSEL bits TOP Command's register must be '10' - code for reading extended line card design and configuration information from TCR4 - TCR18 registers, which are sequential reading using two shift register. The CONF code is '1111' by this extended identification.

The first schematic gives an overview of the different timings for the extended channel identification.

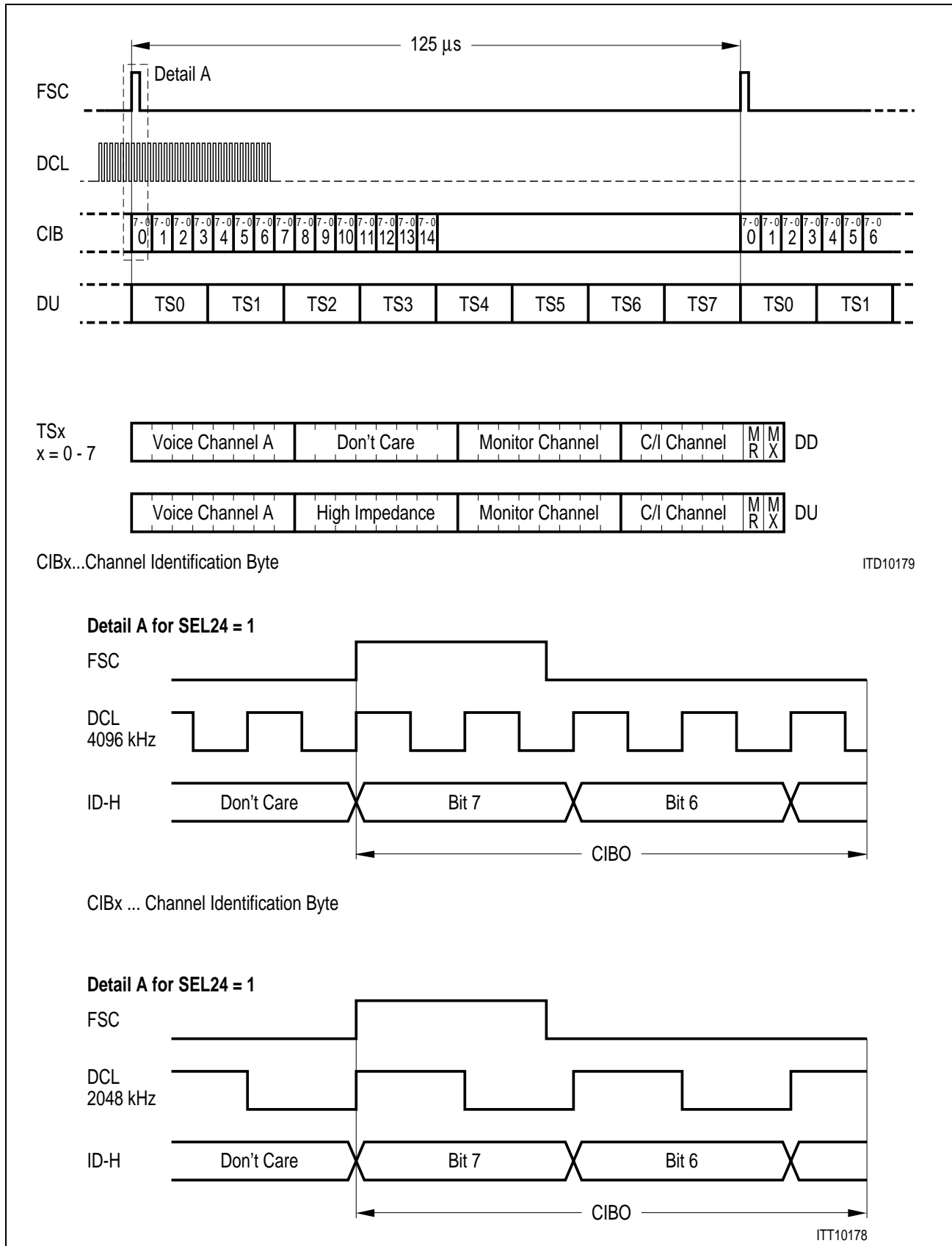

Figure 29 General Timing

Expected Input of the ASIC (via ID - H; ID - L = ID - M 0 = + 5 V)

If - for example - the SLICOFI has the time slot 6 (TSx = 110, see **chapter 4, page 16**, too), the Monitor Channel of TS6 looks like the following (for all other time slots equivalent).

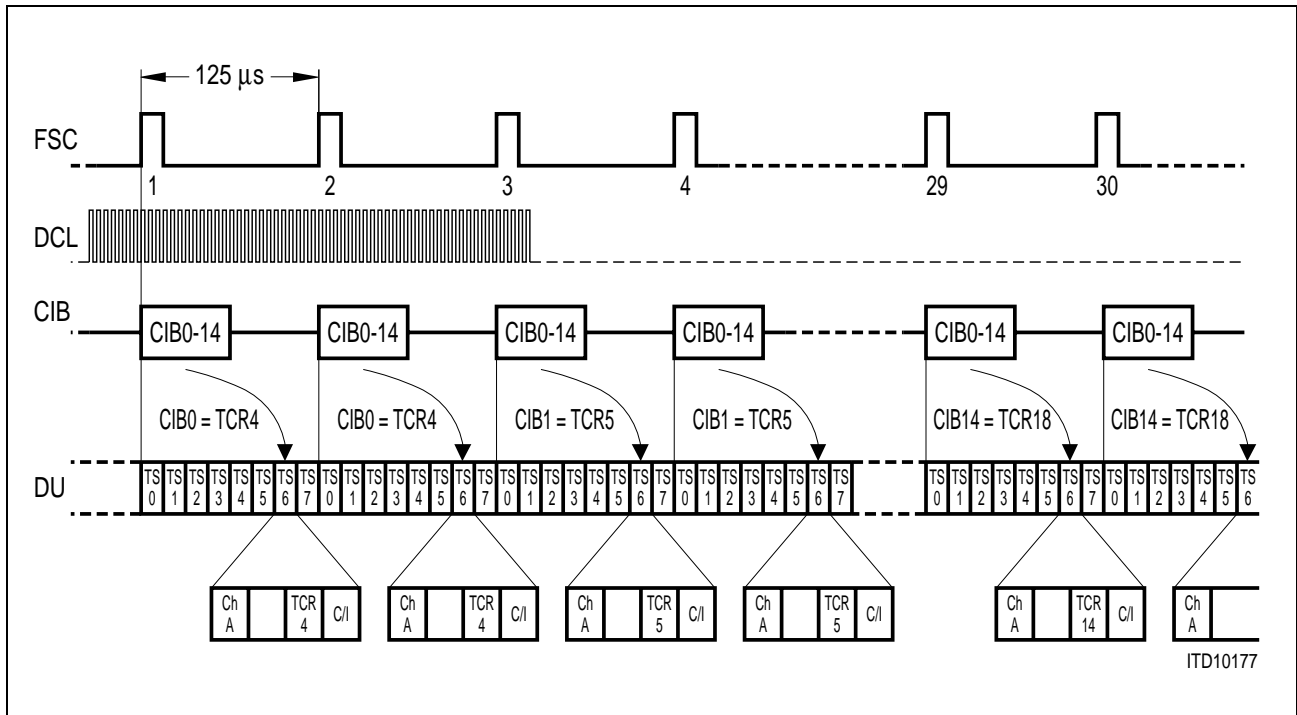

Figure 30

Expected Input Timing and IOM-2 Interface Timing and Switching characteristic: To be defined.

10.3 Test Modes

Various loops and tests (to cut off at different points or disable some filters) for testing either the chip or the board and the line are implemented in the SLICOFI.

Table 32

LB	TM	T3	T2	T1	T0	Testloop
SCR1-5	SCR2-3	SCR6-3	SCR6-2	SCR6-1	SCR6-0	
1	0	0	0	0	1	ALB_ADC
1	0	0	1	0	1	DLB_4M
1	0	1	0	0	0	DLB_PCM
1	0	1	1	0	0	DC_ALB
1	0	all other combinations of T3: T0				don't use
1	1	0	0	0	1	RVP
1	1	0	0	1	0	TVP

Table 32 (cont'd)

LB	TM	T3	T2	T1	T0	Testloop
SCR1-5	SCR2-3	SCR6-3	SCR6-2	SCR6-1	SCR6-0	
1	1	0	0	1	1	LC
1	1	0	1	0	0	RC
1	1	0	1	0	1	ILT
1	1	0	1	1	0	DC-THRU
1	1	all other combinations of T3: T0				don't use
0	X	X	X	X	X	all loops off

Testregister (STCR1 to 8) - Summary

The Testregisters (accessed by the SOP-command with LSEL = 11b) are for internal use only. The 8 Testregisters can only be read or written en bloc. They are enabled/disabled by the Enable Testregister bit ENTR (SCR5-1). For ENTR = 0 the STCRs are set to the basic settings - so no refresh is necessary.

But note there are complex internal connections; so do use only the following two commands: ACDACDIS and EXT_MCLK. All other bits MUST be set as described below.

STCR1 Test Configuration Register 1

Bit	7	6	5	4	3	2	1	0
	0	0	0	0	0	0	0	0

Reset value: 00_H

STCR2 Test Configuration Register 2

Bit	7	6	5	4	3	2	1	0
	0	0	EXT_MCLK	0	0	ACDACDIS	0	0

Reset value: 00_H

general remark All bits of STCR1 are set if necessary automatically by regular testloops. So setting STCR1-bits to '1', together with a testloop, the certain action is inverted.

EXT_MCLK Possibility to provide the SLICOFI with external clock (see also **page 35**, EXT_MCLK, SCR8-4; There are no functional differences between these two settings!)

EXT_MCLK = 0 Internal masterclock is used

EXT_MCLK = 1 External masterclock is used

To use an external masterclock of 16 MHz following steps must be done:

- 1) IO1 must be set to input and becomes the input-pin of the masterclock
- 2) Enable the testregisters (Configuration Register 5: SCR5-1 (ENTR) =1)
- 3) The testregisterblock must be programmed (Test Configuration Register 2: STCR2-5 (EXT_MCLK) = 1)

ACDACDIS Disables AC-DAC
 ACDACDIS = 0 normal operation
 ACDACDIS = 1 disables AC-DAC

STCR3 Test Configuration Register 3

Bit	7	6	5	4	3	2	1	0
	0	0	0	0	0	0	0	0

Reset value: 00_H

STCR4 Test Configuration Register 4

Bit	7	6	5	4	3	2	1	0
	0	1	0	1	1	1	1	1

Reset value: 5F_H

STCR5 Test Configuration Register 5

Bit	7	6	5	4	3	2	1	0
	0	0	0	0	0	0	0	0

Reset value: 00_H

STCR6 to STCR8 Test Configuration Register 6 to 8

Bit	7	6	5	4	3	2	1	0
	0	0	0	0	0	0	0	0

Reset value: 00_H

ALB_ADC

(Analog loop with ADC and DAC)

This testloop feasible the test of AC analog parts including ADC and DAC.

Initializing the testloop:

Reset

Active Mode

Disable Impedance matching filter

(OPIMAN (SCR6_5) = 1, OPIM4M (SCR6_4) = 1, IM (SCR4_6) = 0)

Testloop

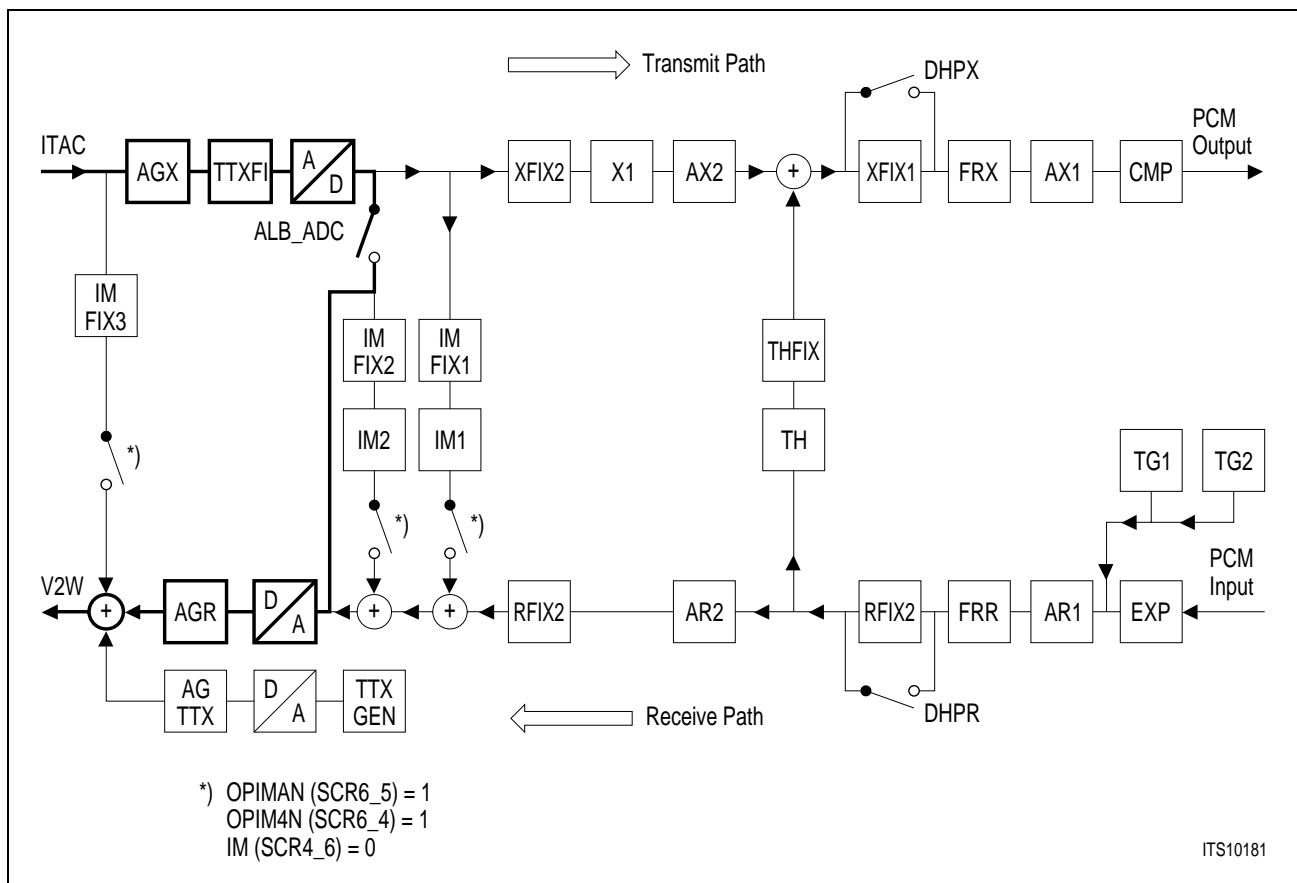

Figure 31

DLB_4M

(Digital loop up to 4 MHz)

This testloop feasible the test of AC digital parts including DSP.

Initializing the testloop:

Reset

Store owns coefficients (generated by SLICOS)

Active Mode

Select programmed coefficients (FIXC (SCR5_5) = 0)

Open Impedance matching and Transhybrid loop

(OPIM4M (SCR6_4) = 1, IM (SCR4_6) = 0, TH (SCR4_7) = 0)

Testloop

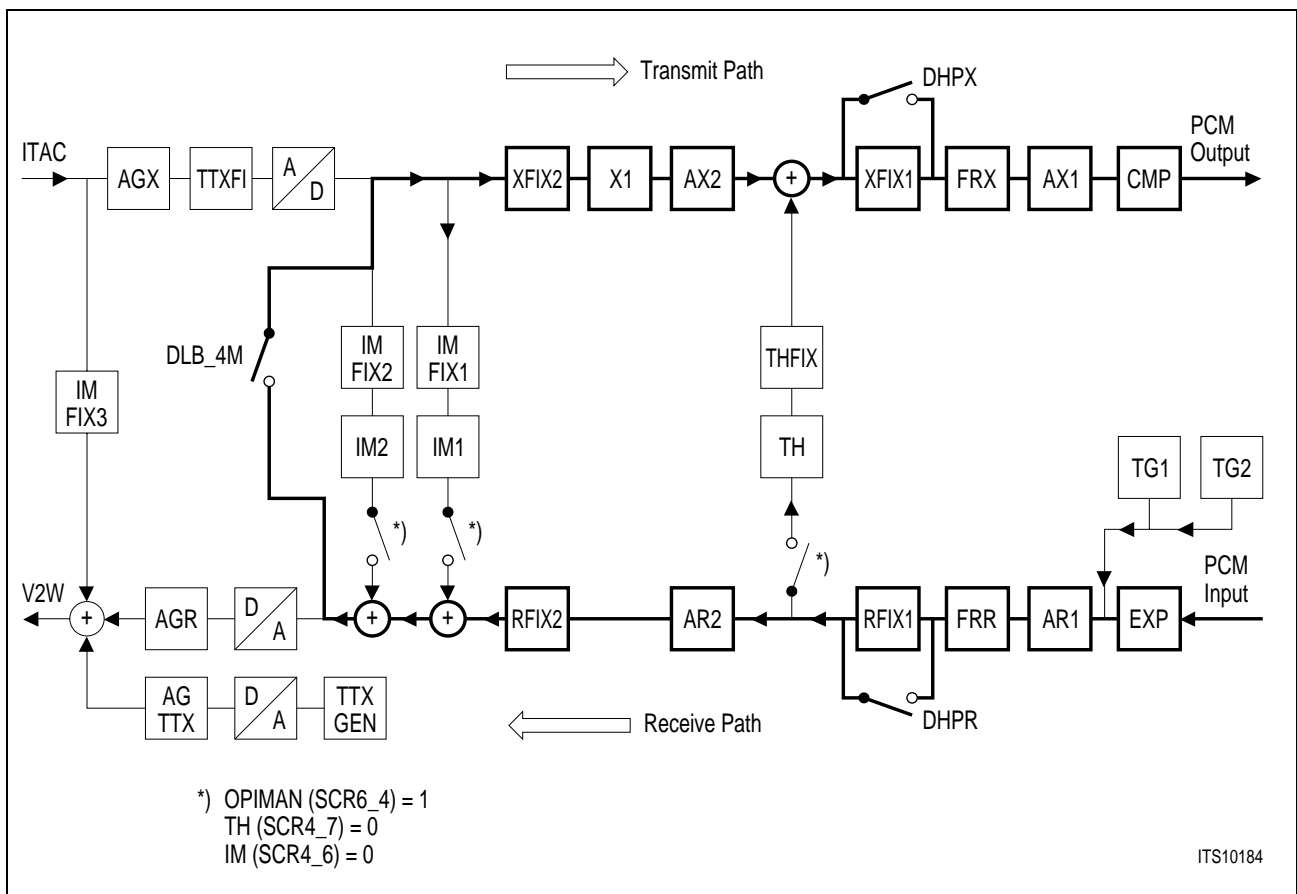

Figure 32

DLB_PCM

(Digital loop only PCM-interface)

This testloop is the basic setting after Reset and the NOT Active Mode.

It releases a shortcut between DD and DU. In Active Mode this loop can be programmed.

Initializing the testloop:

Reset

or in Active Mode:

Testloop

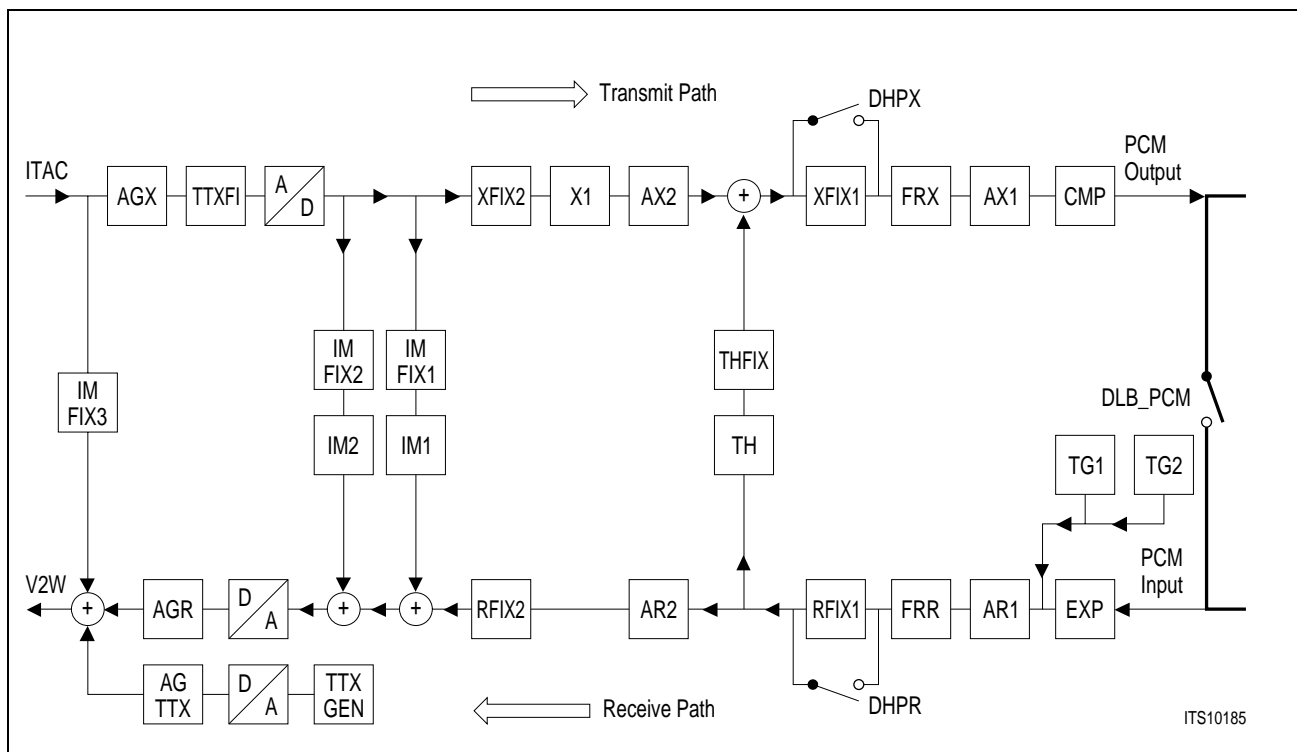

Figure 33

DC_ALB

(DC analog loop)

This testloop feasible the test of the analog DC parts (max. frequency of the testsignal 4 kHz).

Initializing the testloop:

Reset

Active Mode

Open analog loop (OPIMAN (SCR6_5) = 1, ACDACDIS (STCR2_2) = 1)

Testloop

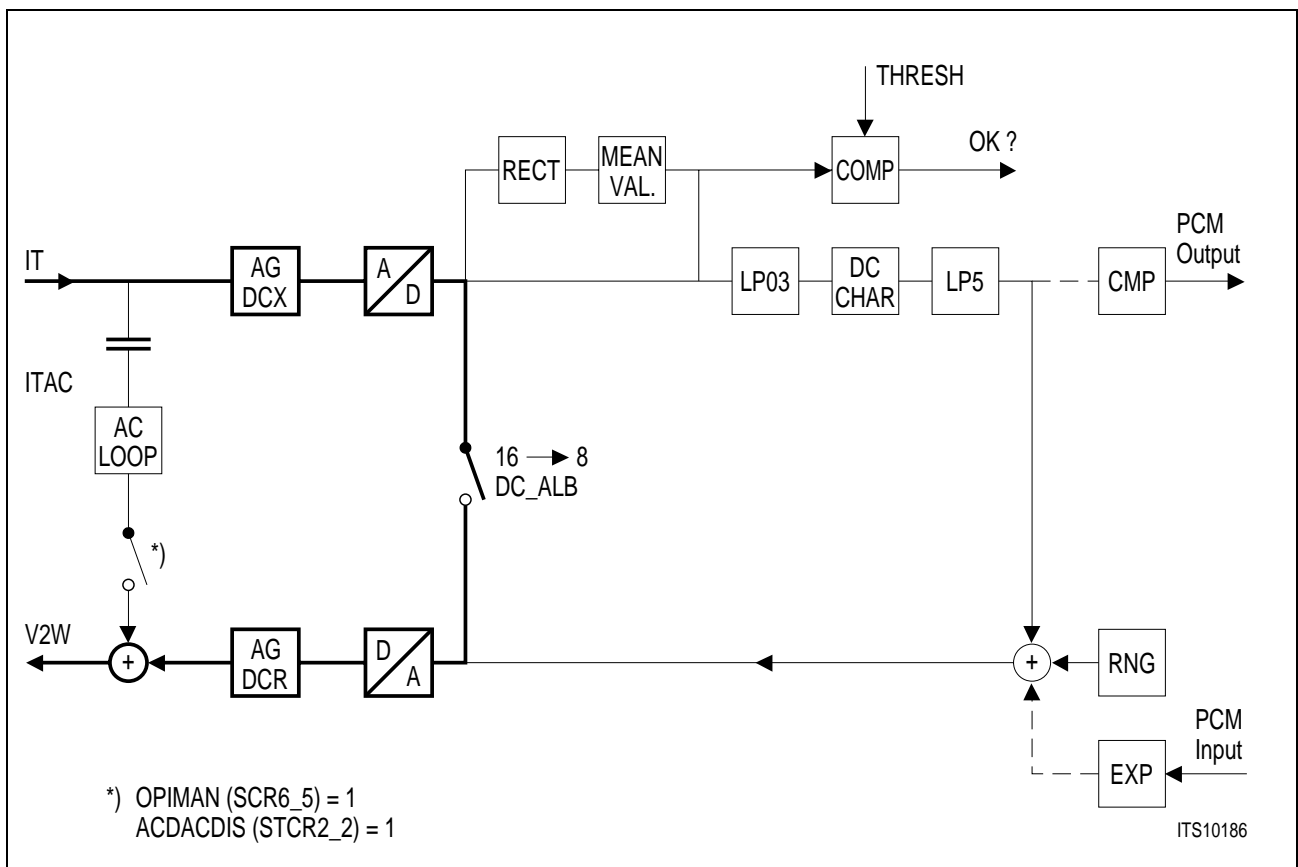

Figure 34

RVP

(Ringer voltage present)

This testloop feasible the test of the ringer burst level.

Initializing the testloop:

Reset

Store own's coefficients and voltage level for measurement

(generated by SLICOS)

Select programmed coefficients (FIXC (SCR5_5) = 0)

Open analog loop (OPIMAN (SCR6_5) = 1, ACDACDIS (STCR2_2) = 1)

Ringing Mode, Ring Burst On (RBO) command

Testloop

Test condition is indicated in MVA (SCR2_7) and result of the comparison is stored in OKRNG (SCR2_4). The mean value can get at PCM Output, too.

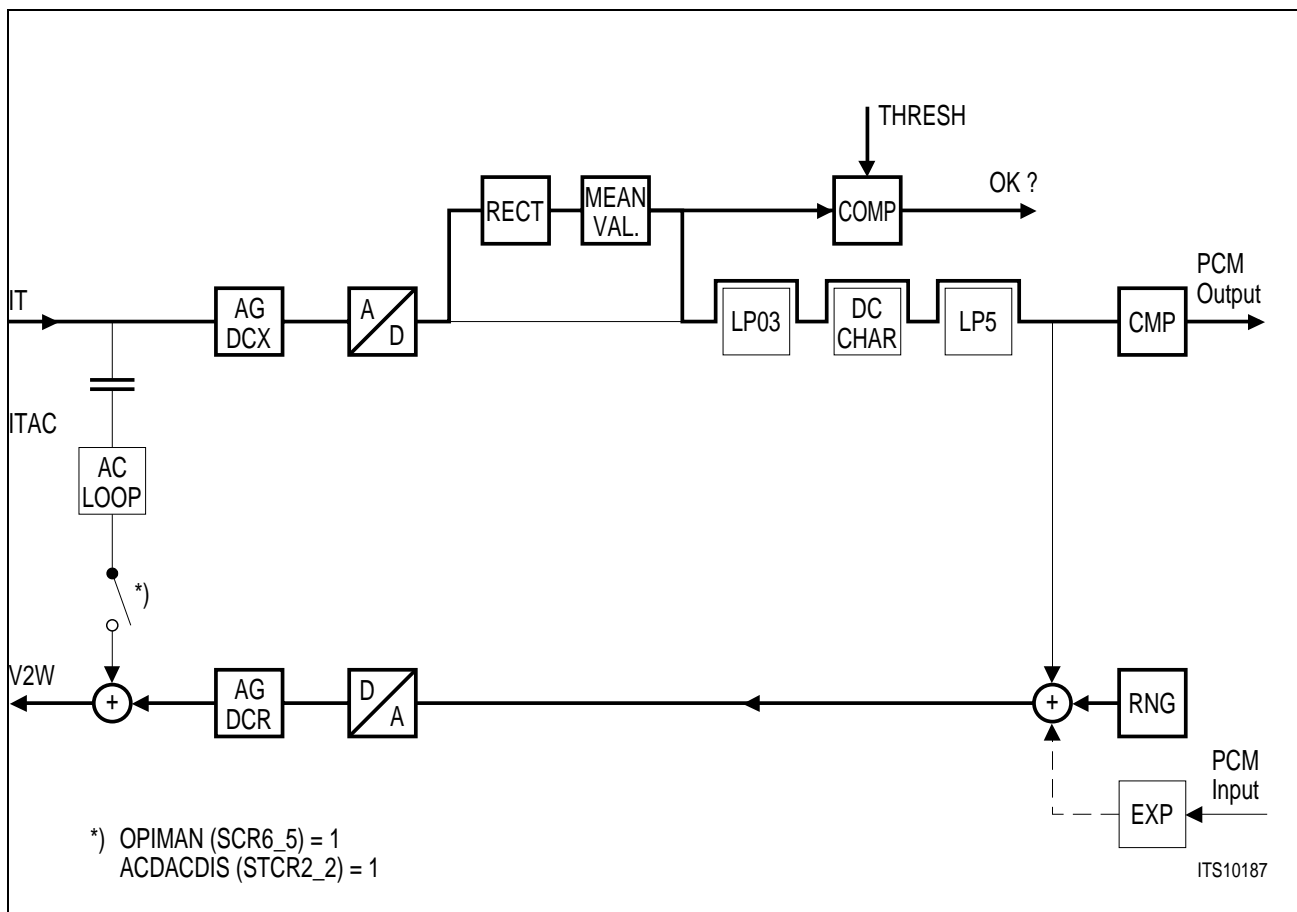

Figure 35

TVP

(Teletax voltage present)

This testloop feasible the test of the teletax burst level which includes the test of TTX adaptation and basic functions of HV-SLIC.

Initializing the testloop:

Reset

Store own's coefficients and voltage level for measurement (generated by SLICOS)

Select programmed coefficients (FIXC (SCR5_5) = 0)

Active Mode, Teletax Burst On: TTXNO (SCR3_7) = 0

Testloop

Test condition is indicated in MVA (SCR2_7) and result of the comparison is stored in OKTTX (SCR2_5). The rectified value can get at PCM Output, too. (During the testloop the last DC value is hold.)

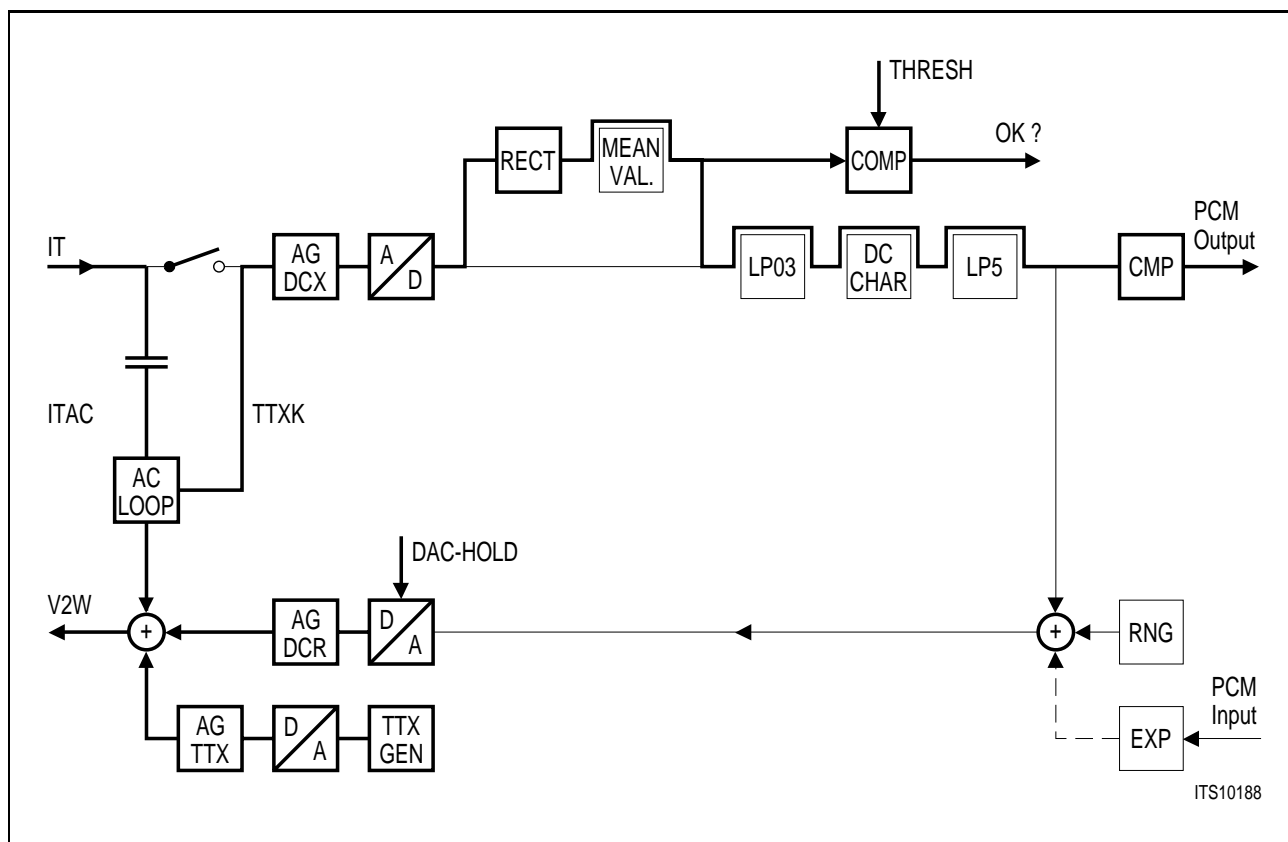

Figure 36

LC

(Loop current measurement)

This testloop feasible a DC test of the line (shortcut, resistance, operating point) and basic function of the HV-SLIC.

Initializing the testloop:

Reset

Store own coefficients (generated by SLICOS)

Select programmed coefficients (FIXC (SCR5_5) = 0)

Open analog loop (OPIMAN (SCR6_5) = 1, ACDACDIS (STCR2_2) = 1)

Active Mode

Testloop

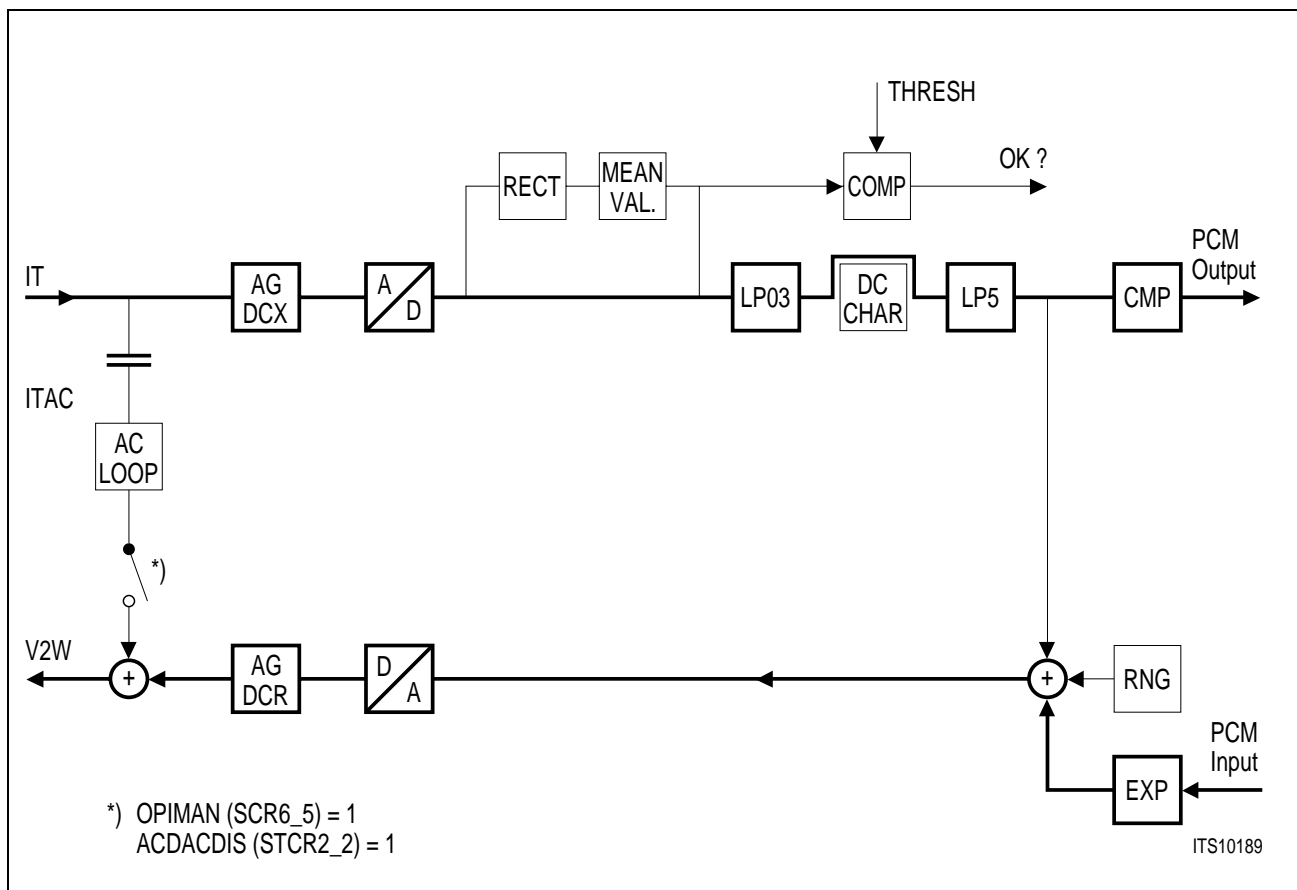

Figure 37

RC

(Ringer capacitance measurement)

This testloop feasible the test of the line concerning the ringer.

Initializing the testloop:

Reset

Store own's coefficients (generated by SLICOS)

Select programmed coefficients (FIXC (SCR5_5) = 0)

Open analog loop (OPIMAN (SCR6_5) = 1, ACDACDIS (STCR2_2) = 1)

Ringing Mode, Ring Burst On (RBO) command

Testloop

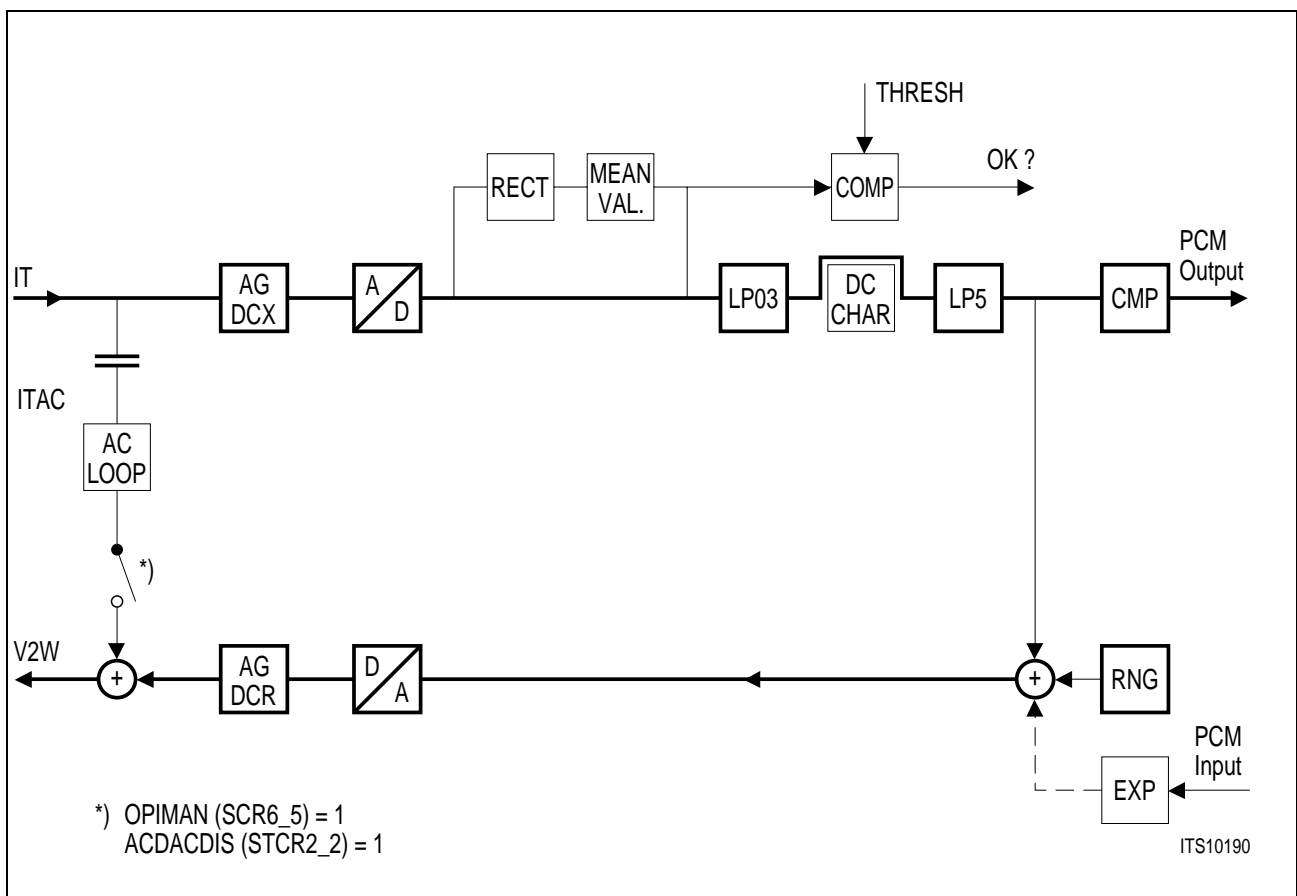

Figure 38

ILT

(Longitudinal current measurement)

This testloop feasible the test of the line.

Initializing the testloop:

Reset

Store own coefficients (generated by SLICOS)

Select programmed coefficients (FIXC (SCR5_5) = 0)

Open analog loop (OPIMAN (SCR6_5) = 1, ACDACDIS (STCR2_2) = 1)

Active Mode

Testloop

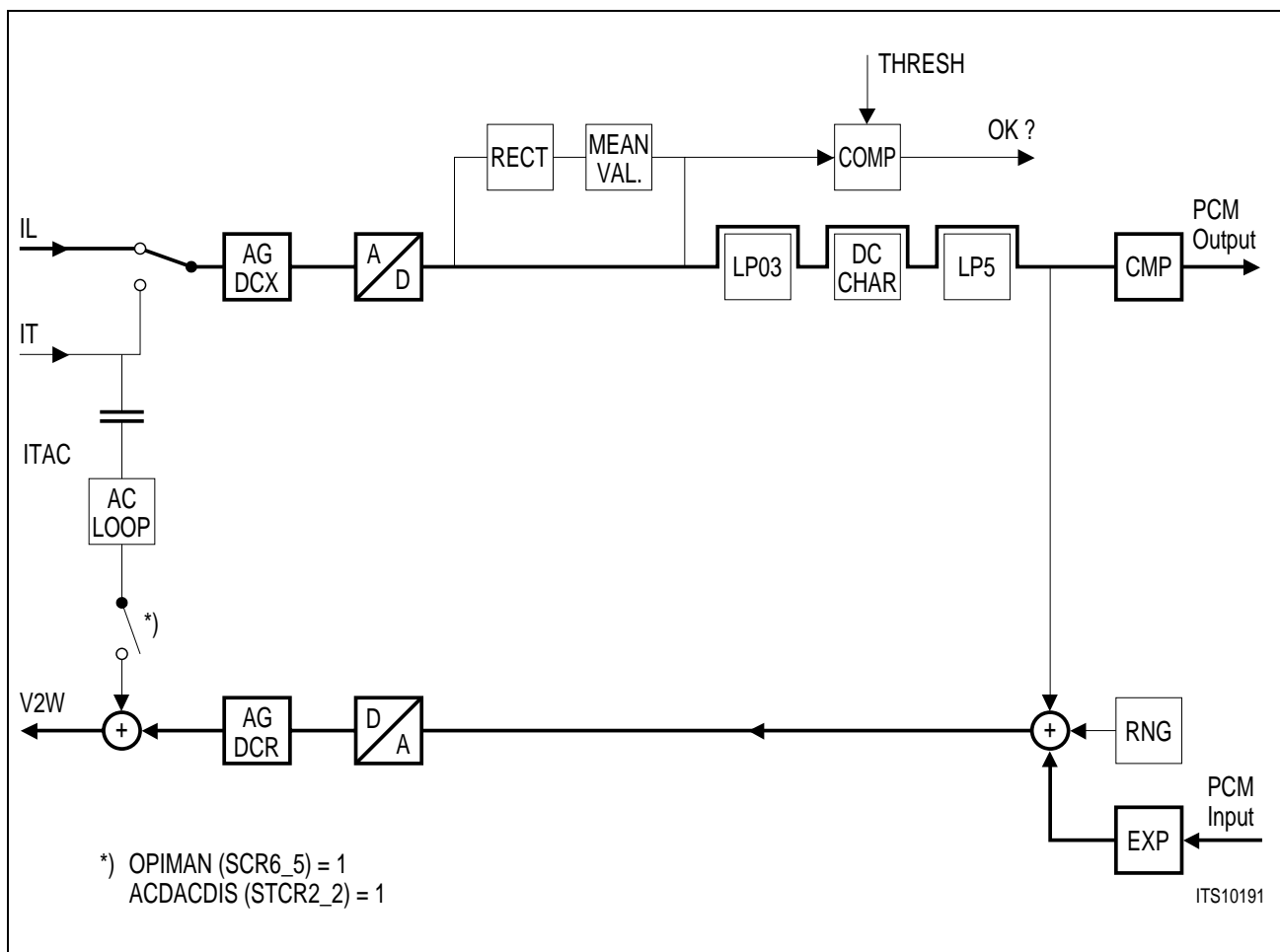

Figure 39

DC_THRU (DC loop)

This testloop feasible the test of the DC parts.

Initializing the testloop:

- Reset
- PDown Mode (AC-Loop disactivated)
- Testloop

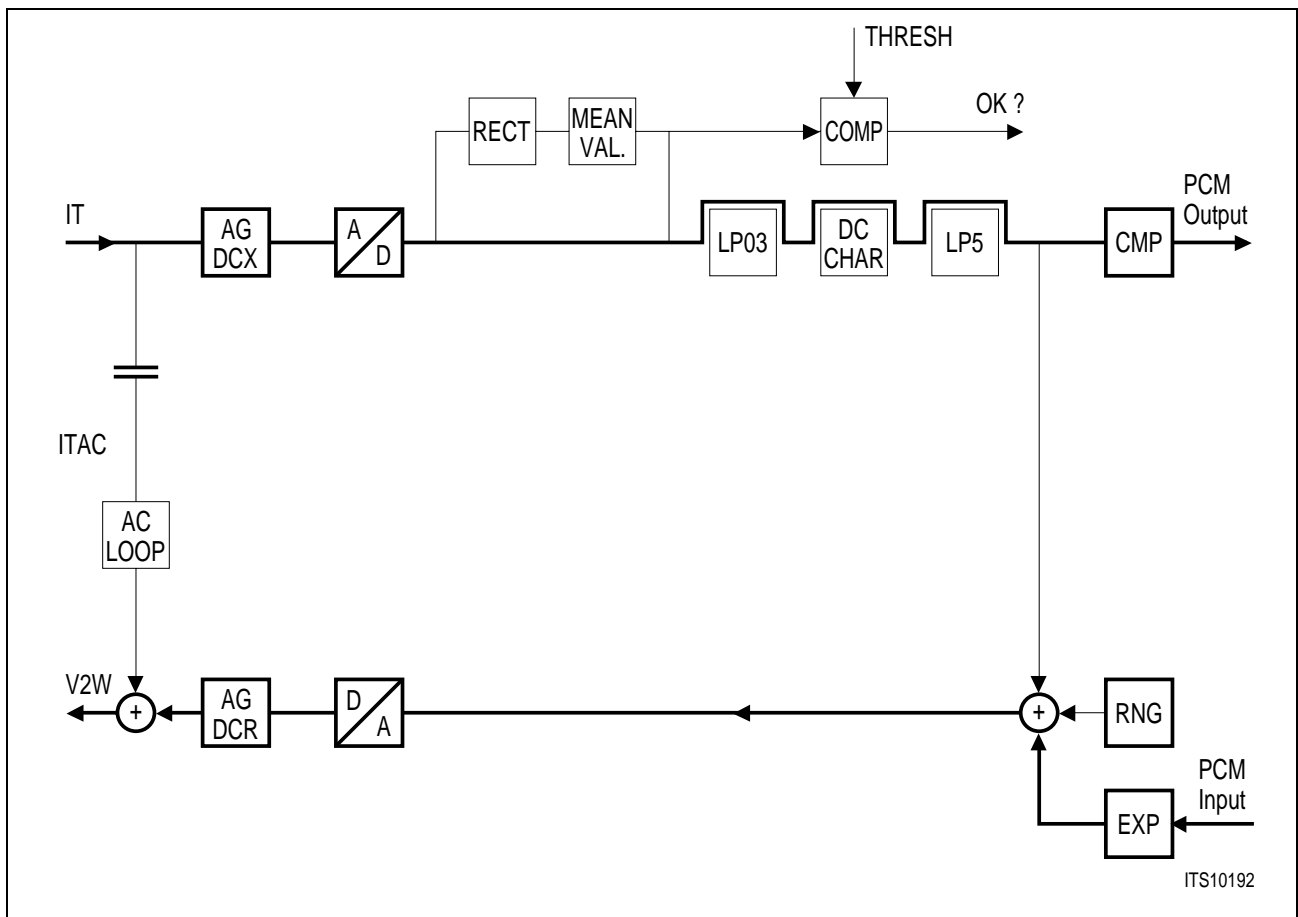

Figure 40

10.4 List of Abbreviations

Act	Active Mode
ADC	Analog Digital Converter
AGDCR	Attenuation DC Receive
AGDCX	Attenuation DC Transmit
AGR	Attenuation Receive
AGX	Attenuation Transmit
AGTTX	Attenuation Teletax
AR	Attenuation Receive
ASIC	Application Specific Integrated Circuit
AX	Attenuation Transmit
BB	Boosted Battery
BiCMOS	Bipolar Complementary Metal Oxid Semiconductor
BP	Band Pass
C/I-DD	Channel Identification-Data Downstream
C/I-DU	Channel Identification-Data Upstream
C1, 2	Digital Interface to HV-SLIC
CAP	External Capacitor to GNDA
CCITT	Comité Consultatif International de Telephone et Telegraph
CHOP	Chopper (see SCR8_6)
CMP	Compander
CODEC	Coder Decoder
COMP	Comparator (Testloops, Levelmetering)
COP	Coefficient Operation
CRAM	Coefficient RAM
DAC	Digital Analog Converter
DAC-HOLD	DC DAC Hold (Testloop TVP)
DBP	Deutsche Bundes Post
DCCHAR	DC Characteristic block
DCL	Data Clock
DD	Data Downstream

DHP_R	Disable Receive Highpass (SCR5_7)
DHP_X	Disable Transmit Highpass (SCR1_1)
DSP	Digital Signal Processor
DU	Data Upstream
DUP	Data Upstream Persistency Counter
DUPGNK	Data Upstream Persistency Counter for GNK
EXP	Expander
FRR	Frequency Response Receive Filter
FRX	Frequency Response Transmit Filter
FSC	Frame Sync.
GNDIT	Analog Ground
GNK	Ground Key
HV-SLIC	High Voltage Subscriber Line Interface Circuit
I1	Fixed Input Pin
ID-L	External Identification
ID-M	External Identification
IH-H	External Identification
IL	Longitudinal Current Input
IM	Impedance Matching Filter (programmable)
IMFIX	Impedance Matching Filter (fixed)
IO	User Programmable I/O Pin
IOM-2-Interface	ISDN Oriented Modular Interface
ISDN	Integrated Service Digital Network
IT	Transversal Current Input (for AC and DC)
ITAC	Transversal Current Input (for AC)

LP03	Low Pass 0.3 Hz
LP5	Low Pass 5 Hz
LSSGR	Local area transport access Switching System Generic Requirements
MEAN VAL.	Mean Value (Testloops, Levelmetering)
MR	Monitor Receive
MX	Monitor Transmit
O1	Fixed Output Pin
PCM	Pulse Code Modulation
PDen	Power Denial
PDN	Power Down
PDN	PDN Pin (Sets the HV SLIC to Power Denial)
POFI	Post Filter
PREFI	Antialiasing Pre Filter
RB	Ring Burst
RECT	Rectifier (Testloops, Levelmetering)
RES	Reset
REXT	External Ring Sync. Input
RFIX	Receive Filter (fixed)
RNG	Ring Generator
RREF	External Resistor to GNDA
SCR	Status Configuration Register
SEL24	Select Data Clock 2 or 4 MHz
SLIC	Subscriber Line Interface Circuit
SLICOS	SLICOFI Oriented Software
SLMA	Subscriber Loop Marging
SLXC	Summary Line Card Outputs
SOP	Status Operation
STCR	Status Test Configuration Register

TCR	Transfer Configuration Register
TE 1-3	Test Pin
TG	Tone Generator
TH	Transhybrid Balancing
THFIX	Transhybrid Balancing Filter (fixed)
THRESH	Threshold (Testloops, Levelmetering)
TOP	Transfer Operation
TS	Time Slot
TS 0-2	Time Slot selection Pin
TTX	Teletax
TTXFI	Teletax Adaptation
TTXGEN	Teletax Generator
V_{2W}	Two Wire Output Voltage
V_{BIM}	Battery Image Input
$V_{LINE1, 2}$	Offhook-Detection in Power Denial Mode
X	Transmit Filter (programmable)
XFIX	Transmit Filter (fixed)

11 Package Outlines

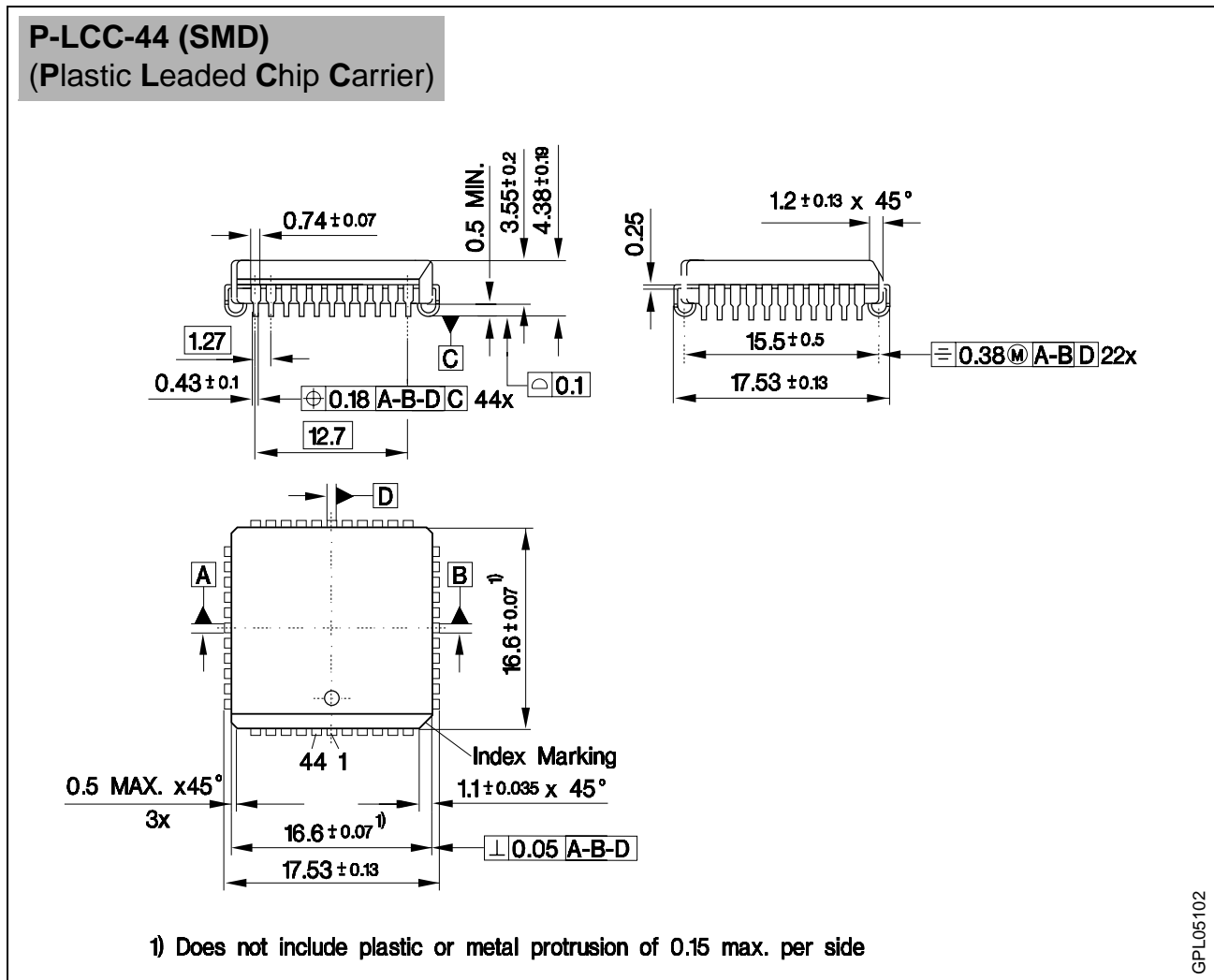

Figure 41

Sorts of Packing

Package outlines for tubes, trays etc. are contained in our Data Book "Package Information"

SMD = Surface Mounted Device

Dimensions in mm