

High Speed Multifrequency PLL Clock Buffer

Features

- 12–100 MHz (CY7B9930V), or 24–200 MHz (CY7B9940V) input/output operation
- Matched pair output skew < 200 ps
- Zero input-to-output delay
- 10 LVTTTL 50% duty-cycle outputs capable of driving 50Ω terminated lines
- Commercial temperature range with eight outputs at 200 MHz
- Industrial temperature range with eight outputs at 200 MHz
- 3.3V LVTTTL/LV differential (LVPECL), fault-tolerant and hot insertable reference inputs
- Multiply ratios of (1–6, 8, 10, 12)
- Operation up to 12x input frequency
- Individual output bank disable for aggressive power management and EMI reduction
- Output high impedance option for testing purposes
- Fully integrated PLL with lock indicator
- Low cycle-to-cycle jitter (<100 ps peak-peak)
- Single 3.3V ± 10% supply
- 44-pin TQFP package

Functional Description

The CY7B9930V and CY7B9940V High-Speed Multifrequency PLL Clock Buffers offer user-selectable control over system clock functions. This multiple output clock driver provides the system integrator with functions necessary to optimize the timing of high performance computer or communication systems.

Ten configurable outputs can each drive terminated transmission lines with impedances as low as 50Ω while delivering minimal and specified output skews at LVTTTL levels. The outputs are arranged in three banks. The FB feedback bank consists of two outputs, which allows divide-by functionality from 1 to 12. Any one of these ten outputs can be connected to the feedback input as well as driving other inputs.

Selectable reference input is a fault tolerance feature that allows smooth change over to secondary clock source, when the primary clock source is not in operation. The reference inputs are configurable to accommodate both LVTTTL or differential (LVPECL) inputs. The completely integrated PLL reduces jitter and simplifies board layout.

Logic Block Diagram

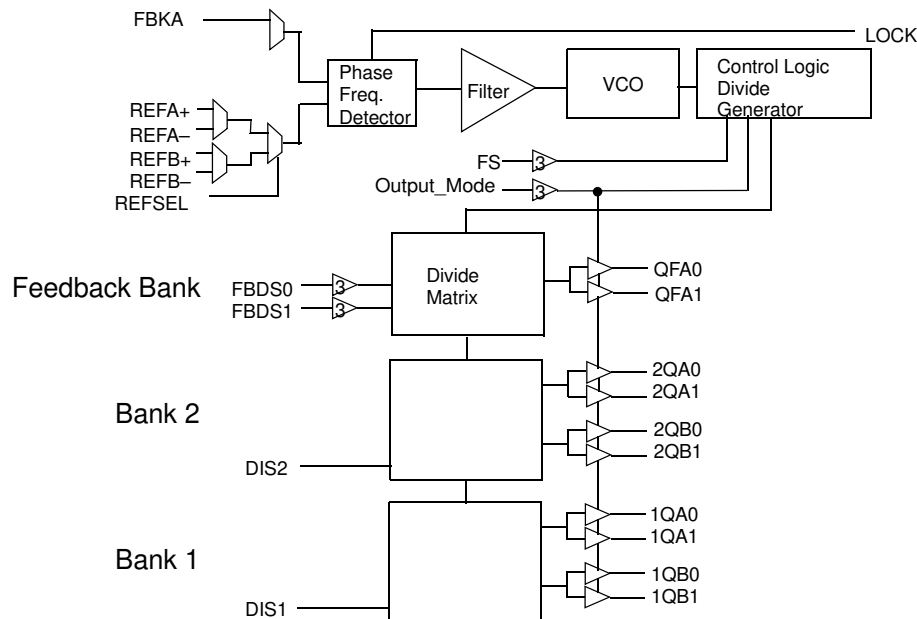

Contents

Features	1	Operating Range	6
Functional Description	1	Electrical Characteristics Over the Operating Range	6
Logic Block Diagram	1	Capacitance	7
Contents	2	Switching Characteristics	7
Logic Block Diagram Description	3	AC Timing Diagrams	9
Phase Frequency Detector and Filter	3	Ordering Information	10
VCO, Control Logic, and Divide Generator	3	Package Diagram	10
Divide Matrix	3	Document History Page	11
Output Disable Description	3	Sales, Solutions, and Legal Information	12
Lock Detect Output Description	4	Worldwide Sales and Design Support	12
Factory Test Mode Description	4	Products	12
Pin Definitions	5	PSoC Solutions	12
Absolute Maximum Conditions	6		

Logic Block Diagram Description

Phase Frequency Detector and Filter

These two blocks accept signals from the REF inputs (REFA+, REFA-, REFB+ or REFB-) and the FB input (FBKA). Correction information is then generated to control the frequency of the Voltage Controlled Oscillator (VCO). These two blocks, along with the VCO, form a Phase-Locked Loop (PLL) that tracks the incoming REF signal.

The RoboClockII™ Junior has a flexible REF input scheme. These inputs allow the use of either differential LVPECL or single ended LVTTTL inputs. To configure as single ended LVTTTL inputs, leave the complementary pin to 1.5V, then use the other input pin as an LVTTTL input. The REF inputs are also tolerant to hot insertion.

The REF inputs can be changed dynamically. When changing from one reference input to the other reference input of the same frequency, the PLL is optimized to ensure that the clock outputs period is not less than the calculated system budget ($t_{MIN} = t_{REF}$ (nominal reference clock period) - t_{CCJ} (cycle-to-cycle jitter) - t_{PDEV} (max. period deviation)) while reacquiring lock.

VCO, Control Logic, and Divide Generator

The VCO accepts analog control inputs from the PLL filter block. The FS control pin setting determines the nominal operational frequency range of the divide by one output (f_{NOM}) of the device. f_{NOM} is directly related to the VCO frequency. There are two versions of the RoboClockII Junior, a low speed device (CY7B9930V) where f_{NOM} ranges from 12 MHz to 100 MHz, and a high speed device (CY7B9940V), which ranges from 24 MHz to 200 MHz. The FS setting for each device is shown in Table 1. The f_{NOM} frequency is seen on “divide-by-one” outputs.

Table 1. Frequency Range Select

FS ^[1]	CY7B9930V		CY7B9940V	
	f_{NOM} (MHz)		f_{NOM} (MHz)	
	Min.	Max.	Min.	Max.
LOW	12	26	24	52
MID	24	52	48	100
HIGH	48	100	96	200 ^[2]

Notes

1. The level to be set on FS is determined by the “nominal” operating frequency (f_{NOM}) of the VCO. f_{NOM} always appears on an output when the output is operating in the undivided mode. The REF and FB are at f_{NOM} when the output connected to FB is undivided.
2. The maximum output frequency is 200 MHz.

Divide Matrix

The Divide Matrix is comprised of three independent banks: two banks of clock outputs and one bank for feedback. Each clock output bank has two pairs of low-skew, high fanout output buffers ([1:2]Q[A:B][0:1]), and an output disable (DIS[1:2]).

The feedback bank has one pair of low-skew, high fanout output buffers (QFA[0:1]). One of these outputs may connect to the selected feedback input (FBKA+). This feedback bank also has two divider function selects FBDS[0:1].

The divide capabilities for each bank are shown in Table 2.

Table 2. Output Divider Function

Function Selects		Output Divider Function		
FBDS1	FBDS0	Bank 1	Bank 2	Feedback Bank
LOW	LOW	/1	/1	/1
LOW	MID	/1	/1	/2
LOW	HIGH	/1	/1	/3
MID	LOW	/1	/1	/4
MID	MID	/1	/1	/5
MID	HIGH	/1	/1	/6
HIGH	LOW	/1	/1	/8
HIGH	MID	/1	/1	/10
HIGH	HIGH	/1	/1	/12

Output Disable Description

The outputs of Bank 1 and Bank 2 can be independently put into a HOLD OFF or high impedance state. The combination of the Output_Mode and DIS[1:2] inputs determines the clock outputs' state for each bank. When the DIS[1:2] is LOW, the outputs of the corresponding bank are enabled. When the DIS[1:2] is HIGH, the outputs for that bank are disabled to a high impedance (HI-Z) or HOLD OFF state depending on the Output_Mode input. Table 3 defines the disabled output functions.

The HOLD OFF state is designed as a power saving feature. An output bank is disabled to the HOLD OFF state in a maximum of six output clock cycles from the time when the disable input (DIS[1:2]) is HIGH. When disabled to the HOLD OFF state, outputs are driven to a logic LOW state on its falling edge. This ensures the output clocks are stopped without glitch. When a bank of outputs is disabled to HI-Z state, the respective bank of outputs go HI-Z immediately.

Table 3. DIS[1:2] Pin Functionality

OUTPUT_MODE	DIS[1:2]/FBDIS	Output Mode
HIGH/LOW	LOW	ENABLED
HIGH	HIGH	HI-Z
LOW	HIGH	HOLD-OFF
MID	X	FACTORY TEST

Lock Detect Output Description

The LOCK detect output indicates the lock condition of the integrated PLL. Lock detection is accomplished by comparing the phase difference between the reference and feedback inputs. Phase error is declared when the phase difference between the two inputs is greater than the specified device propagation delay limit (t_{PD}).

When in the locked state, after four or more consecutive feedback clock cycles with phase errors, the LOCK output is forced LOW to indicate out-of-lock state.

When in the out-of-lock state, 32 consecutive phase errorless feedback clock cycles are required to allow the LOCK output to indicate lock condition (LOCK = HIGH).

If the feedback clock is removed after LOCK has gone HIGH, a Watchdog circuit is implemented to indicate the out-of-lock

condition after a timeout period by deasserting LOCK LOW. This timeout period is based upon a divided down reference clock.

This assumes that there is activity on the selected REF input. If there is no activity on the selected REF input then the LOCK detect pin may not accurately reflect the state of the internal PLL.

Factory Test Mode Description

The device enters factory test mode when the OUTPUT_MODE is driven to MID. In factory test mode, the device operates with its internal PLL disconnected; the input level supplied to the reference input is used in place of the PLL output. In TEST mode the selected FB input must be tied LOW. All functions of the device remain operational in factory test mode except the internal PLL and output bank disables. The OUTPUT_MODE input is designed as a static input. Dynamically toggling this input from LOW to HIGH may temporarily cause the device to go into factory test mode (when passing through the MID state).

Factory Test Reset

When in factory test mode (OUTPUT_MODE = MID), the device is reset to a deterministic state by driving the DIS2 input HIGH. When the DIS2 input is driven HIGH in factory test mode, all clock outputs go to HI-Z; after the selected reference clock pin has five positive transitions, all the internal finite state machines (FSM) are set to a deterministic state. The deterministic state of the state machines depends on the configurations of the divide selects and frequency select input. All clock outputs stay in high impedance mode and all FSMs stay in the deterministic state until DIS2 is deasserted. When DIS2 is deasserted (with OUTPUT_MODE still at MID), the device reenters factory test mode.

Pin Definitions

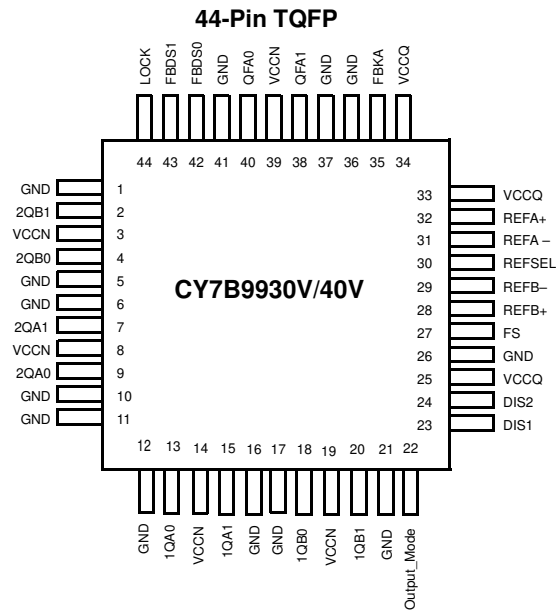

Name	I/O	Type	Description
FBKA	Input	LVTTTL	Feedback Input.
REFA+, REFA-, REFB+, REFB-	Input	LVTTTL/ LVDIFF	Reference Inputs: These inputs operate as either differential PECL or single ended TTL reference inputs to the PLL. When operating as a single ended LVTTTL input, leave the complementary input must be left open.
REFSEL	Input	LVTTTL	Reference Select Input: The REFSEL input controls reference input configuration. When LOW, it uses the REFA pair as the reference input. When HIGH, it uses the REFB pair as the reference input. This input has an internal pull down.
FS ^[3]	Input	3 Level Input	Frequency Select: Set this input according to the nominal frequency (f_{NOM}). See Table 1 .
FBDS[0:1] ^[3]	Input	3 Level Input	Feedback Divider Function Select. These inputs determine the function of the QFA0 and QFA1 outputs. See Table 2 .
DIS[1:2]	Input	LVTTTL	Output Disable: Each input controls the state of the respective output bank. When HIGH, the output bank is disabled to the “HOLD OFF” or “HI-Z” state; the disable state is determined by OUTPUT_MODE. When LOW, the [1:4]Q[A:B][0:1] is enabled. See Table 3 . These inputs each have an internal pull down.
LOCK	Output	LVTTTL	PLL Lock Indicator: When HIGH, this output indicates that the internal PLL is locked to the reference signal. When LOW, the PLL is attempting to acquire lock.
Output_Mode ^[3]	Input	3 Level Input	Output Mode: This pin determines the clock outputs’ disable state. When this input is HIGH, the clock outputs disable to high impedance (HI-Z). When this input is LOW, the clock outputs disables to “HOLD OFF” mode. When in MID, the device enters factory test mode.
QFA[0:1]	Output	LVTTTL	Clock Feedback Output: This pair of clock outputs connects to the FB input. These outputs have numerous divide options. The function is determined by the setting of the FBDS[0:1] pins.
[1:2]Q[A:B][0:1]	Output	LVTTTL	Clock Output.
VCCN		PWR	Output Buffer Power: Power supply for each output pair.
VCCQ		PWR	Internal Power: Power supply for the internal circuitry.
GND		PWR	Device Ground.

Note

3. For all tri-state inputs, HIGH indicates a connection to V_{CC} , LOW indicates a connection to GND, and MID indicates an open connection. Internal termination circuitry holds an unconnected input to $V_{CC}/2$.

Absolute Maximum Conditions

Exceeding the maximum ratings may impair the useful life of the device. These user guidelines are not tested.

Storage temperature -40°C to +125°C
 Ambient Temperature with power applied -40°C to +125°C
 Supply voltage to ground potential -0.5V to +4.6V
 DC input voltage -0.3V to $V_{CC}+0.5V$
 Output current into outputs (LOW) 40 mA

Static discharge voltage..... >2000V
 MIL-STD-883, Method 3015)

Latch up current..... >±200 mA

Operating Range

Range	Ambient Temperature	V_{CC}
Commercial	0°C to +70°C	3.3V ±10%
Industrial	-40°C to +85°C	3.3V ±10%

Electrical Characteristics Over the Operating Range

Parameter	Description	Test Conditions	Min.	Max.	Unit	
LVTTTL Compatible Output Pins (QFA[0:1], [1:4]Q[A:B][0:1], LOCK)						
V_{OH}	LVTTTL HIGH voltage	QFA[0:1], [1:2]Q[A:B][0:1]	$V_{CC} = \text{Min.}, I_{OH} = -30 \text{ mA}$	2.4	–	V
		LOCK	$I_{OH} = -2 \text{ mA}, V_{CC} = \text{Min.}$	2.4	–	V
V_{OL}	LVTTTL LOW voltage	QFA[0:1], [1:2]Q[A:B][0:1]	$V_{CC} = \text{Min.}, I_{OL} = 30 \text{ mA}$	–	0.5	V
		LOCK	$I_{OL} = 2 \text{ mA}, V_{CC} = \text{Min.}$	–	0.5	V
I_{OZ}	High impedance state leakage current		-100	100	μA	
LVTTTL Compatible Input Pins (FBKA, REFA±, REFB±, REFSEL, DIS[1:2])						
V_{IH}	LVTTTL Input HIGH	FBKA+, REF[A:B]±	$\text{Min.} \leq V_{CC} \leq \text{Max.}$	2.0	$V_{CC}+0.3$	V
		REFSEL, DIS[1:2]		2.0	$V_{CC}+0.3$	V
V_{IL}	LVTTTL Input LOW	FBKA+, REF[A:B]±	$\text{Min.} \leq V_{CC} \leq \text{Max.}$	-0.3	0.8	V
		REFSEL, DIS[1:2]		-0.3	0.8	V
I_I	LVTTTL $V_{IN} > V_{CC}$	FBKA+, REF[A:B]±	$V_{CC} = \text{GND}, V_{IN} = 3.63V$	–	100	μA
I_{IH}	LVTTTL Input HIGH Current	FBKA+, REF[A:B]±	$V_{CC} = \text{Max.}, V_{IN} = V_{CC}$	–	500	μA
		REFSEL, DIS[1:2]	$V_{IN} = V_{CC}$	–	500	μA
I_{IL}	LVTTTL Input LOW Current	FBKA+, REF[A:B]±	$V_{CC} = \text{Max.}, V_{IN} = \text{GND}$	-500	–	μA
		REFSEL, DIS[1:2]		-500	–	μA
3-Level Input Pins (FBDS[0:1], FS, Output_Mode)						
V_{IHH}	Three level input HIGH ^[4]		$\text{Min.} \leq V_{CC} \leq \text{Max.}$	$0.87 \cdot V_{CC}$	–	V
V_{IMM}	Three level input MID ^[4]		$\text{Min.} \leq V_{CC} \leq \text{Max.}$	$0.47 \cdot V_{CC}$	$0.53 \cdot V_{CC}$	V
V_{ILL}	Three level input LOW ^[4]		$\text{Min.} \leq V_{CC} \leq \text{Max.}$		$0.13 \cdot V_{CC}$	V
I_{IHH}	Three level input HIGH current	Three level input pins	$V_{IN} = V_{CC}$	–	200	μA
I_{IMM}	Three level input MID current	Three level input pins	$V_{IN} = V_{CC}/2$	-50	50	μA
I_{ILL}	Three level input LOW current	Three level input pins	$V_{IN} = \text{GND}$	-200	–	μA
LVDIFF Input Pins (REF[A:B]±)						
V_{DIFF}	Input differential voltage			400	V_{CC}	mV
V_{IHHP}	Highest input HIGH voltage			1.0	V_{CC}	V
V_{ILLP}	Lowest input LOW voltage			GND	$V_{CC} - 0.4$	V
V_{COM}	Common mode range (crossing voltage)			0.8	V_{CC}	V

Note

4. These inputs are normally wired to V_{CC} , GND, or left unconnected (actual threshold voltages vary as a percentage of V_{CC}). Internal termination resistors hold the unconnected inputs at $V_{CC}/2$. If these inputs are switched, the function and timing of the outputs may glitch and the PLL may require an additional t_{LOCK} time before all data sheet limits are achieved.

Electrical Characteristics Over the Operating Range (continued)

Parameter	Description		Test Conditions	Min.	Max.	Unit
Operating Current						
I _{CCI}	Internal operating current	CY7B9930V	V _{CC} = Max., f _{MAX} ^[5]	–	200	mA
		CY7B9940V		–	200	mA
I _{CCN}	Output current dissipation/pair ^[6]	CY7B9930V	V _{CC} = Max., C _{LOAD} = 25 pF, R _{LOAD} = 50Ω at V _{CC} /2, f _{MAX}	–	40	mA
		CY7B9940V		–	50	mA

Capacitance

Parameter	Description	Test Conditions	Min.	Max.	Unit
C _{IN}	Input capacitance	T _A = 25°C, f = 1 MHz, V _{CC} = 3.3V	–	5	pF

Switching Characteristics

Over the Operating Range^[7, 8, 9, 10, 11]

Parameter	Description		CY7B9930/40V-2		CY7B9930/40V-5		Unit
			Min.	Max.	Min.	Max.	
f _{in}	Clock input frequency	CY7B9930V	12	100	12	100	MHz
		CY7B9940V	24	200	24	200	MHz
f _{out}	Clock output frequency	CY7B9930V	12	100	12	100	MHz
		CY7B9940V	24	200	24	200	MHz
t _{SKEWPR}	Matched pair skew ^[12, 13]		–	185	–	185	ps
t _{SKEWBK}	Intrabank skew ^[12, 13]		–	200	–	250	ps
t _{SKEW0}	Output-Output skew (same frequency and phase, rise to rise, fall to fall) ^[12, 13]		–	250	–	550	ps
t _{SKEW1}	Output-Output skew (same frequency and phase, other banks at different frequency, rise to rise, fall to fall) ^[12, 13]		–	250	–	650	ps
t _{CCJ1-3}	Cycle-to-cycle jitter (divide by 1 output frequency, FB = divide by 1, 2, 3)		–	150	–	150	ps Peak-Peak
t _{CCJ4-12}	Cycle-to-cycle jitter (divide by 1 output frequency, FB = divide by 4, 5, 6, 8, 10, 12)		–	100	–	100	ps Peak-Peak
t _{PD}	Propagation delay, REF to FB Rise		–250	250	–500	500	ps
t _{PDELTA}	Propagation delay difference between two devices ^[14]		–	200		200	ps
t _{REFpwh}	REF input (pulse width HIGH) ^[15]		2.0	–	2.0	–	ns
t _{REFpwl}	REF input (pulse width LOW) ^[15]		2.0	–	2.0	–	ns
t _r /t _f	Output rise/fall time ^[16]		0.15	2.0	0.15	2.0	ns

Notes

5. I_{CCI} measurement is performed with Bank1 and FB Bank configured to run at maximum frequency (f_{NOM} = 100 MHz for CY7B9930V, f_{NOM} = 200 MHz for CY7B9940V), and all other clock output banks to run at half the maximum frequency. FS and OUTPUT_MODE are asserted to the HIGH state.
6. This is dependent upon frequency and number of outputs of a bank being loaded. The value indicates maximum I_{CCN} at maximum frequency and maximum load of 25 pF terminated to 50Ω at V_{CC}/2.
7. This is for non-three level inputs.
8. Assumes 25 pF Max. Load Capacitance up to 185 Mhz. At 200 MHz the max load is 10 pF.
9. Both outputs of pair must be terminated, even if only one is being used.
10. Each package must be properly decoupled.
11. AC parameters are measured at 1.5V, unless otherwise indicated.
12. Test Load C_L = 25 pF, terminated to V_{CC}/2 with 50Ω.
13. SKEW is defined as the time between the earliest and the latest output transition among all outputs for which the same phase delay has been selected when all outputs are loaded with 25 pF and properly terminated up to 185 MHz. At 200 MHz the max load is 10 pF.
14. Guaranteed by statistical correlation. Tested initially and after any design or process changes that may affect these parameters.
15. Tested initially and after any design or process changes that may affect these parameters.
16. Rise and fall times are measured between 2.0V and 0.8V.

Switching Characteristics

Over the Operating Range^[7, 8, 9, 10, 11] (continued)

Parameter	Description	CY7B9930/40V-2		CY7B9930/40V-5		Unit
		Min.	Max.	Min.	Max.	
t_{LOCK}	PLL lock time from power up	–	10	–	10	ms
$t_{RELOCK1}$	PLL relock time (from same frequency, different phase) with stable power supply	–	500	–	500	μ s
$t_{RELOCK2}$	PLL Relock Time (from different frequency, different phase) with Stable Power Supply ^[17]	–	1000	–	1000	μ s
t_{ODCV}	Output duty cycle deviation from 50% ^[11]	–1.0	1.0	–1.0	1.0	ns
t_{PWH}	Output HIGH time deviation from 50% ^[18]	–	1.5	–	1.5	ns
t_{PWL}	Output LOW time deviation from 50% ^[18]	–	2.0	–	2.0	ns
t_{PDEV}	Period deviation when changing from reference to reference ^[19]	–	0.025	–	0.025	UI
t_{OAZ}	DIS[1:2] HIGH to output high impedance from ACTIVE ^[12, 20]	1.0	10	1.0	10	ns
t_{OZA}	DIS[1:2] LOW to output ACTIVE from output is high impedance ^[20, 21]	0.5	14	0.5	14	ns

Figure 1. AC Test Loads and Waveform ^[22]

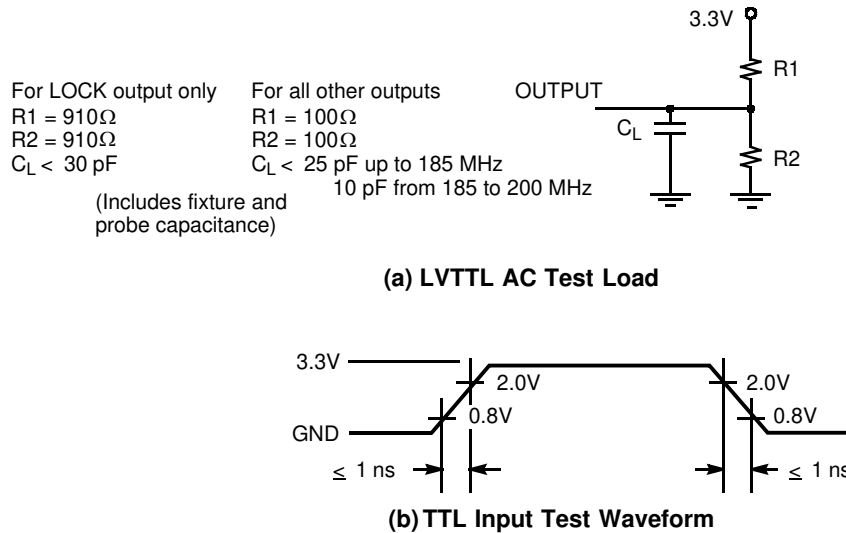

Notes

17. f_{NOM} must be within the frequency range defined by the same FS state.
18. t_{PWH} is measured at 2.0V. t_{PWL} is measured at 0.8V.
19. UI = Unit Interval. Examples: 1 UI is a full period. 0.1 UI is 10% of period.
20. Measured at 0.5V deviation from starting voltage.
21. For t_{OZA} minimum, C_L = 0 pF. For t_{OZA} maximum, C_L = 25 pF to 18 MHz, 10 pF from 185 to 200 MHz.
22. These figures are for illustration only. The actual ATE loads may vary.

AC Timing Diagrams

See note. [11]

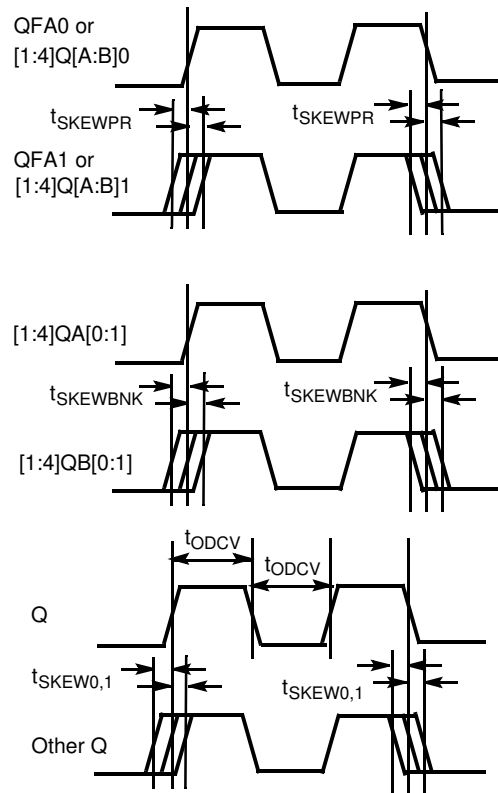
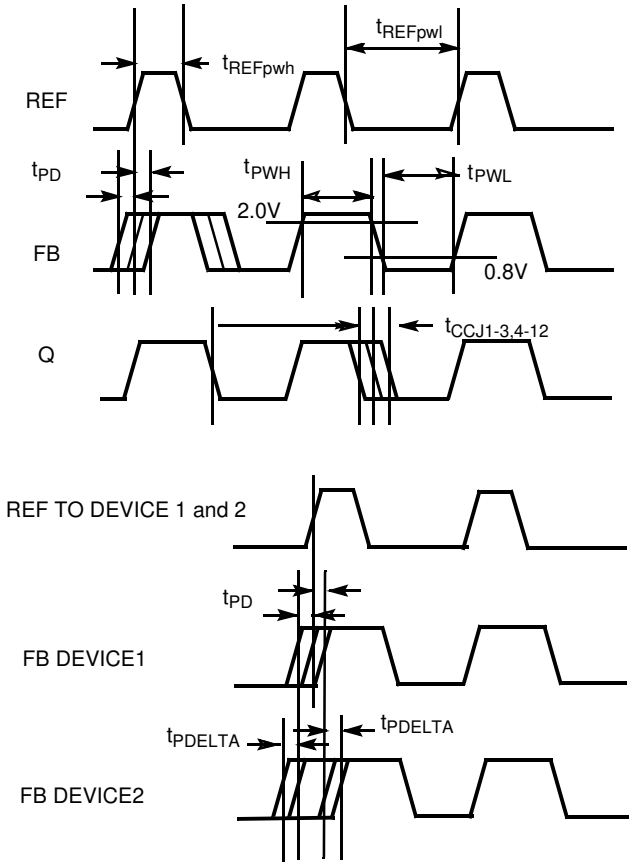

Ordering Information

Propagation Delay (ps)	Max Speed (MHz)	Ordering Code	Package Type	Operating Range
Pb-free				
500	100	CY7B9930V-5AXC	44-Lead Thin Quad Flat Pack	Commercial
500	100	CY7B9930V-5AXCT	44-Lead Thin Quad Flat Pack–Tape and Reel	Commercial
500	200	CY7B9940V-5AXC	44-Lead Thin Quad Flat Pack	Commercial
500	200	CY7B9940V-5AXCT	44-Lead Thin Quad Flat Pack–Tape and Reel	
500	200	CY7B9940V-5AXI	44-Lead Thin Quad Flat Pack	Industrial
500	200	CY7B9940V-5AXIT	44-Lead Thin Quad Flat Pack–Tape and Reel	
250	200	CY7B9940V-2AXC	44-Lead Thin Quad Flat Pack	Commercial
250	200	CY7B9940V-2AXCT	44-Lead Thin Quad Flat Pack–Tape and Reel	
250	200	CY7B9940V-2AXI	44-Lead Thin Quad Flat Pack	Industrial
250	200	CY7B9940V-2AXIT	44-Lead Thin Quad Flat Pack–Tape and Reel	

Package Diagram

Figure 2. 44-Pin TQFP Package Outline

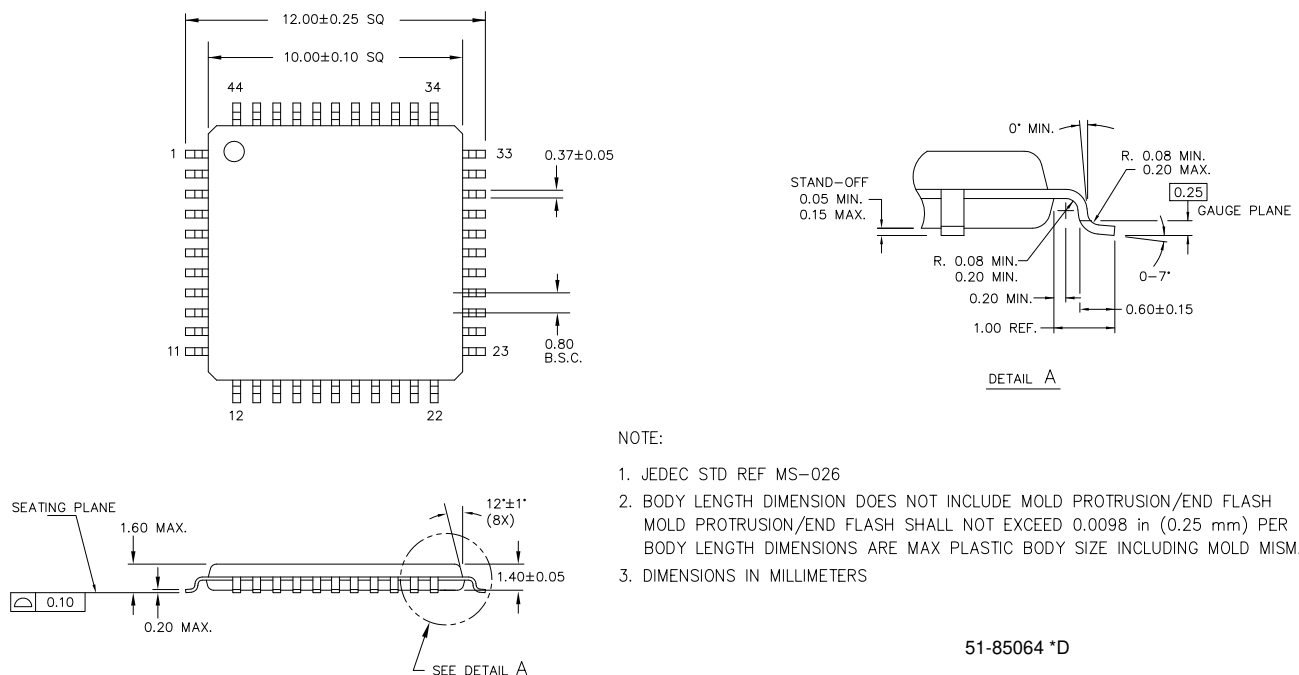

Document History Page

Document Title: RoboClockII™ Junior, CY7B9930V, CY7B9940V High Speed Multifrequency PLL Clock Buffer Document Number: 38-07271				
Rev.	ECN No.	Submission Date	Orig. of Change	Description of Change
**	110536	12/02/01	SZV	Change from Spec number: 38-01141
*A	115109	7/03/02	HWT	Add 44TQFP package for both CY7B9930/40V – Industrial Operating Range
*B	128463	7/29/03	RGL	Added clock input frequency (f_{in}) specifications in the switching characteristics table. Added Min. values for the clock output frequency (f_{out}) in the switching characteristics table.
*C	1346903	8/8/07	WWZ/VED/ ARI	Update the ordering info to reflect the current status and Pb-free part numbers. Implemented new template. Updated the package diagram.
*D	2894960	03/18/2010	KVM	Added Table of Contents Removed part numbers CY7B9930V-5AC, CY7B9930V-5AI, CY7B9940V-5AC, CY7B9940V-5AI, CY7B9930V-2AC, CY7B9930V-2AI and CY7B9940V-2AI in ordering information table. Updated package diagram Added Sales, Solutions, and Legal Information
*E	2906750	04/07/2010	KVM	Removed inactive part from Ordering Information table.

Sales, Solutions, and Legal Information

Worldwide Sales and Design Support

Cypress maintains a worldwide network of offices, solution centers, manufacturer's representatives, and distributors. To find the office closest to you, visit us at [Cypress Locations](#).

Products

Automotive	cypress.com/go/automotive
Clocks & Buffers	cypress.com/go/clocks
Interface	cypress.com/go/interface
Lighting & Power Control	cypress.com/go/powerpsoc cypress.com/go/plc
Memory	cypress.com/go/memory
Optical & Image Sensing	cypress.com/go/image
PSoC	cypress.com/go/psoc
Touch Sensing	cypress.com/go/touch
USB Controllers	cypress.com/go/USB
Wireless/RF	cypress.com/go/wireless

PSoC Solutions

psoc.cypress.com/solutions
PSoC 1 | PSoC 3 | PSoC 5

© Cypress Semiconductor Corporation, 2007-2010. The information contained herein is subject to change without notice. Cypress Semiconductor Corporation assumes no responsibility for the use of any circuitry other than circuitry embodied in a Cypress product. Nor does it convey or imply any license under patent or other rights. Cypress products are not warranted nor intended to be used for medical, life support, life saving, critical control or safety applications, unless pursuant to an express written agreement with Cypress. Furthermore, Cypress does not authorize its products for use as critical components in life-support systems where a malfunction or failure may reasonably be expected to result in significant injury to the user. The inclusion of Cypress products in life-support systems application implies that the manufacturer assumes all risk of such use and in doing so indemnifies Cypress against all charges.

Any Source Code (software and/or firmware) is owned by Cypress Semiconductor Corporation (Cypress) and is protected by and subject to worldwide patent protection (United States and foreign), United States copyright laws and international treaty provisions. Cypress hereby grants to licensee a personal, non-exclusive, non-transferable license to copy, use, modify, create derivative works of, and compile the Cypress Source Code and derivative works for the sole purpose of creating custom software and or firmware in support of licensee product to be used only in conjunction with a Cypress integrated circuit as specified in the applicable agreement. Any reproduction, modification, translation, compilation, or representation of this Source Code except as specified above is prohibited without the express written permission of Cypress.

Disclaimer: CYPRESS MAKES NO WARRANTY OF ANY KIND, EXPRESS OR IMPLIED, WITH REGARD TO THIS MATERIAL, INCLUDING, BUT NOT LIMITED TO, THE IMPLIED WARRANTIES OF MERCHANTABILITY AND FITNESS FOR A PARTICULAR PURPOSE. Cypress reserves the right to make changes without further notice to the materials described herein. Cypress does not assume any liability arising out of the application or use of any product or circuit described herein. Cypress does not authorize its products for use as critical components in life-support systems where a malfunction or failure may reasonably be expected to result in significant injury to the user. The inclusion of Cypress' product in a life-support systems application implies that the manufacturer assumes all risk of such use and in doing so indemnifies Cypress against all charges.

Use may be limited by and subject to the applicable Cypress software license agreement.