

OV491 companion ISP product brief



available in
a lead-free
package

Compact Image Signal Processor For Surround View Automotive Imaging

OmniVision's OV491 is a compact image signal processor (ISP) companion chip that pairs with OmniVision's portfolio of automotive RAW image sensors for automotive imaging applications. The OV491 is ideally suited to streamline surround view system architectures with dual sensor input capability, and is compatible with OmniVision's OX03A, OX02A, OV2775, OV10650, and OV10640 automotive image sensors.

The OV491's support for dual sensor input enables a system with only two ISP companion chips to process four camera inputs, each up to two megapixels in resolution. The OV491 can process high dynamic range

(HDR) video up to 1080p resolution at 60 frames per second (fps), with dual sensor input processing capabilities up to 30 fps for compatible sensors.

The OV491 comes in an AEC-Q100 Grade 2-qualified 7 x 7 mm BGA package and contains an advanced set of safety mechanisms to enable ASIL rated camera systems.

Find out more at www.ovt.com.



Applications

- Rear View Camera
- Surround View System
- e-Mirror
- Camera Monitoring System (CMS)
- Advanced Driver Assistance System (ADAS)

Product Features

- AEC-Q100 grade 2 qualified
- advanced 150 Mp/s throughput ISP for high quality image capturing and video streaming
- local and global tone mapping support
- up to 3-capture HDR combination
- simultaneous output of fully processed YUV for display-based applications and RAW for machine vision applications
- embedded information including frame counter, temperature, and register data for each image to enable critical automotive safety applications
- auto white balance (AWB)
- automatic exposure control (AEC)/ automatic gain control (AGC)
- supports statistics data of up to four user programmable ROIs
- SCCB master/slave interface for sensor and ASIC configuration
- supports four-wire or two-wire serial interface to retrieve stored firmware from external memory devices, such as EEPROM
- on-chip PLL to generate internal clocks
- on-chip voltage regulator 1.8V to 1.1V
- brown-out detection circuit and output flag
- supports 2x2 lane MIPI RX/TX and 1x4 lane MIPI RX/TX
- supports 12-bit DVP input, shared with MIPI RX (1.2 Gbps/lane)
- supports 12-bit DVP output, shared with MIPI TX
- supports 24-bit DVP output, shared with BT1120 output
- embedded 32-bit RISC processor for high performance and flexibility
- supports 1K bits of one-time programmable memory (OTP)
- JTAG boundary scan

OV491

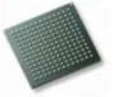

Ordering Information

- **OV00491-B69G-1C** (lead-free) 169-pin BGA, packed in tray
- **OV00491-B69G-TC** (lead-free) 169-pin BGA, packed in tape and reel

Product Specifications

- **power supply:**
 - core: 1.1V ±5%
 - I/O: 1.8V ±5% or 3.3V ±5%
- **power requirements:** 325 mW, measured at 1920 x 1080 @ 30 fps, 12-bit plus 12-bit input from OV2775 via MIPI interface and 1920 x 1080 YUV422 output via MIPI interface
- **temperature range:**
 - operating: -40°C to +105°C ambient temperature and -40°C to +125°C junction temperature
- **package dimensions:** 7 mm x 7 mm

Functional Block Diagram

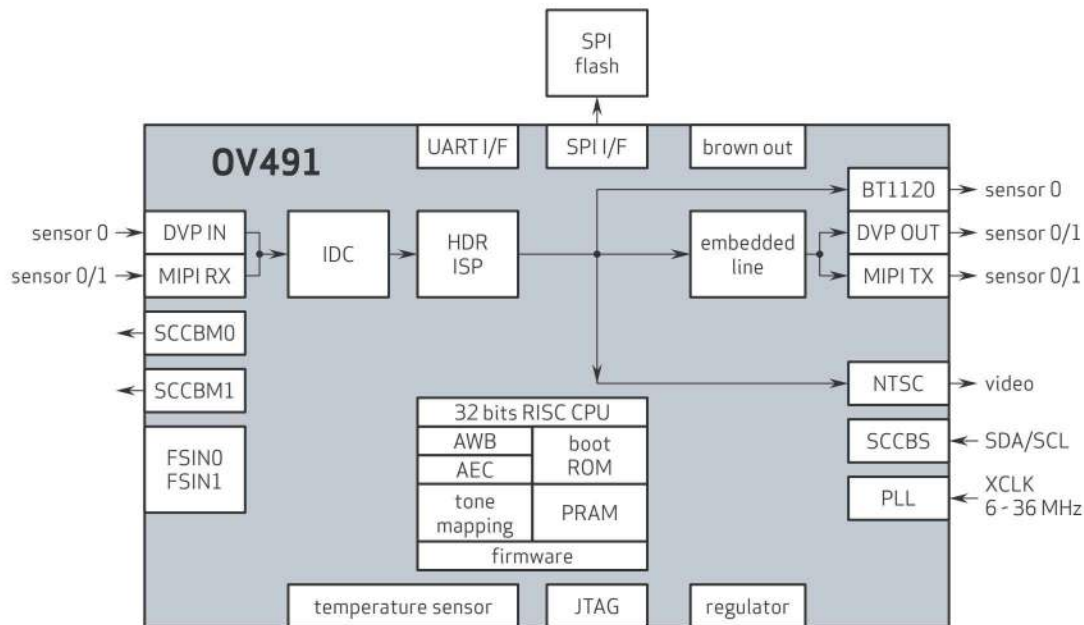

4275 Burton Drive
Santa Clara, CA 95054
USA

Tel: +1 408 567 3000
Fax: +1 408 567 3001
www.ovt.com

OmniVision reserves the right to make changes to their products or to discontinue any product or service without further notice. OmniVision, the OmniVision logo and OmniPixel are registered trademarks of OmniVision Technologies, Inc. OmniBSI-2 is a trademark of OmniVision Technologies, Inc. All other trademarks are the property of their respective owners.



OmniVision