

# IGBT Module

## Single switch

Short Circuit SOA Capability  
Square RBSOA

$I_{C80}$  = 600 A  
 $V_{CES}$  = 6500 V  
 $V_{CE(sat) typ}$  = 4.2 V

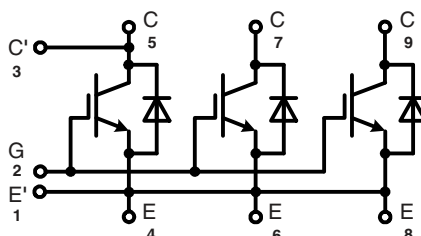

### IGBT

Symbol	Conditions	Maximum Ratings
$V_{CES}$	$V_{GE} = 0 V$	6500 V
$V_{GES}$		$\pm 20 V$
$I_{C85}$	$T_C = 85^\circ C$	600 A
$I_{CM}$	$t_p = 1 ms; T_C = 85^\circ C$	1200 A
$t_{sc}$	$V_{CC} = 4400 V; V_{CEM CHIP} \leq 6500 V;$ $V_{GE} \leq 15 V; T_{VJ} \leq 125^\circ C$	10 $\mu s$

### Features

- NPT<sup>®</sup> IGBT
- Low-loss
- Smooth switching waveforms for good EMC
- Industry standard package
- High power density
- AISiC base-plate for high power cycling capacity
- AlN substrate for low thermal resistance

### Typical Applications

- AC power converters for
  - industrial drives
  - windmills
  - traction
- LASER pulse generator

Symbol	Conditions	Characteristic Values ( $T_{VJ} = 25^\circ C$ , unless otherwise specified)		
		min.	typ.	max.
$V_{CE(sat)} *$	$I_C = 600 A; V_{GE} = 15 V; T_{VJ} = 25^\circ C$ $T_{VJ} = 125^\circ C$		4.2 5.4	V V
$V_{GE(th)}$	$I_C = 240 mA; V_{CE} = V_{GE}$	6		8 V
$I_{CES}$	$V_{CE} = 6500 V; V_{GE} = 0 V; T_{VJ} = 125^\circ C$			120 mA
$I_{GES}$	$V_{CE} = 0 V; V_{GE} = \pm 20 V; T_{VJ} = 125^\circ C$			500 nA
$t_{d(on)}$	Inductive load; $T_{VJ} = 125^\circ C;$ $V_{GE} = \pm 15 V; V_{CC} = 3600 V;$ $I_C = 600 A; L_\sigma = 280 nH$	$R_G = 3.9 \Omega$	620	ns
$t_r$		$R_G = 3.9 \Omega$	270	ns
$t_{d(off)}$		$R_G = 2.7 \Omega$	1500	ns
$t_f$		$R_G = 2.7 \Omega$	930	ns
$E_{on}$		$R_G = 3.9 \Omega$	4250	mJ
$E_{off}$		$R_G = 2.7 \Omega$	3250	mJ
$C_{ies}$	$V_{CE} = 25 V; V_{GE} = 0 V; f = 1 MHz$		150	nF
$C_{oes}$			7.57	nF
$C_{res}$			1.46	nF
$Q_{ge}$	$I_C = 600 A; V_{CE} = 3600 V; V_{GE} = \pm 15 V$		9.65	$\mu C$
$R_{thJC}$				0.011 K/W

\* Collector emitter saturation voltage is given at chip level

Diode			
Symbol	Conditions	Maximum Ratings	
$I_{F80}$	$T_C = 80^\circ\text{C}$	600	A
$I_{FSM}$	$V_R = 0\text{ V}; T_{VJ} = 125^\circ\text{C}; t_p = 10\text{ ms};$ half-sinewave	6000	A

Symbol	Conditions	Characteristic Values		
		min.	typ.	max.
$V_F$ *	$I_F = 600\text{ A};$ $T_{VJ} = 25^\circ\text{C}$ $T_{VJ} = 125^\circ\text{C}$	3.2		V
		3.4		V
$I_{RM}$ $t_{rr}$ $Q_{RR}$ $E_{rec}$	$V_{CC} = 3600\text{ V}; I_C = 600\text{ A};$ $V_{GE} = \pm 15\text{ V}; R_G = 3.9\ \Omega; T_{VJ} = 125^\circ\text{C}$ Inductive load; $L_\sigma = 280\text{ nH}$	930		A
		2200		ns
		1150		$\mu\text{C}$
		2100		mJ
$R_{thJC}$			0.021	K/W

\* Forward voltage is given at chip level

Symbol	Conditions	Maximum Ratings	
$T_{JM}$	max junction temperature	+125	$^\circ\text{C}$
$T_{VJ}$	Operating temperature	-40...+125	$^\circ\text{C}$
$T_{stg}$	Storage temperature	-40...+125	$^\circ\text{C}$
$V_{ISOL}$	50 Hz, 1 min	10200	V~
$M_d$	Mounting torque	Base- heatsink, M6 screws	4 - 6 Nm
		Main terminals, M8 screws	8 - 10 Nm
		Auxiliary terminals, M4 screws	2 - 3 Nm

Symbol	Conditions	Characteristic Values		
		min.	typ.	max.
$d_A$	Clearance distance	terminal to base	40	mm
		IEC 60664-1/EN 50124-1 terminal to terminal	26	mm
$d_S$	Surface creepage dist.	terminal to base	64	mm
		IEC 60664-1/EN 50124-1 terminal to terminal	56	mm
$V_E$	Partial discharge extinction voltage $f = 50\text{ Hz}, Q_{pd} \leq 10\text{ pC}$ (IEC 61287)	5100		V
CTI	Comperative tracking index	600		
$L_\sigma$	Module stray inductance, C to E terminal		18	nH
$R_{term-chip}$ *	Resistance terminal to chip		0.12	m $\Omega$
$R_{thCH}$	per module; $\lambda$ grease = 1 W/m $\cdot$ K		0.006	K/W
Weight			1760	g

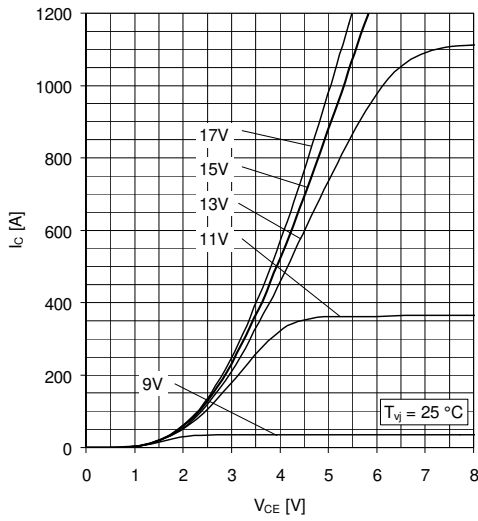

Fig. 1 Typical output characteristics, chip level

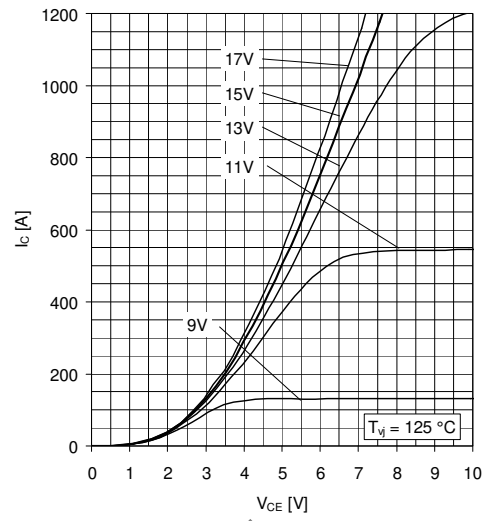

Fig. 2 Typical output characteristics, chip level

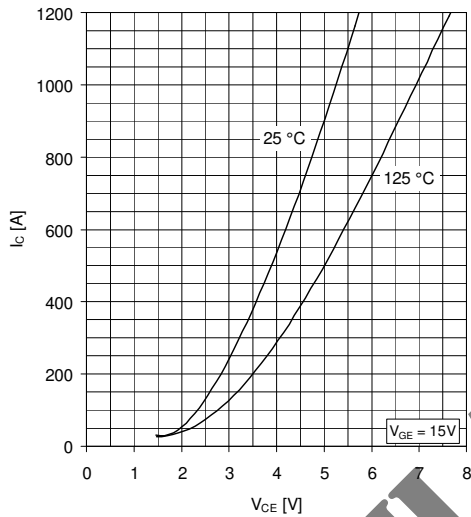

Fig. 3 Typical on-state characteristics, chip level

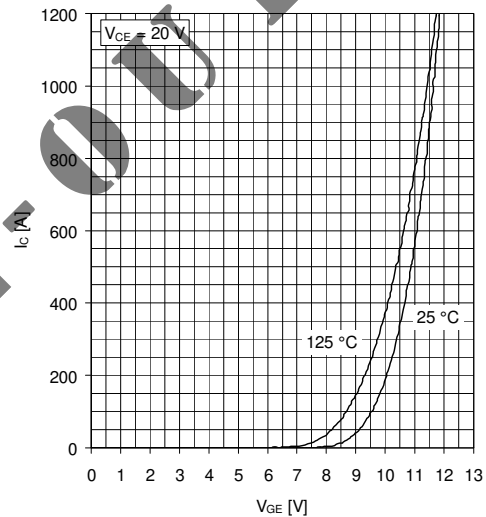

Fig. 4 Typical transfer characteristics, chip level

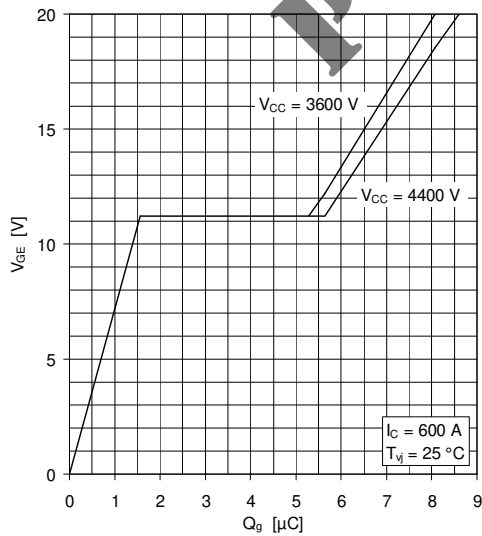

Fig. 5 Typical gate charge characteristics

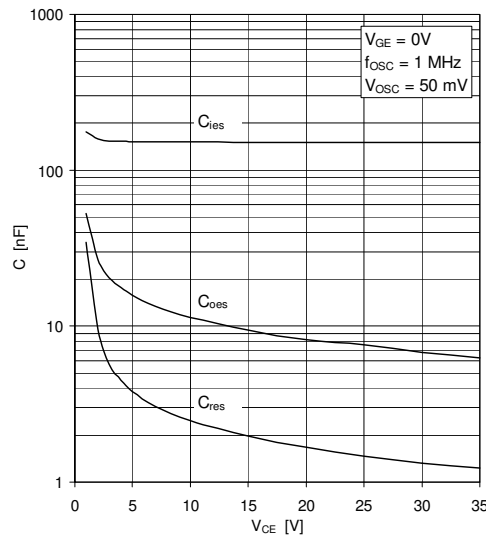

Fig. 6 Typical capacitances vs collector-emitter voltage

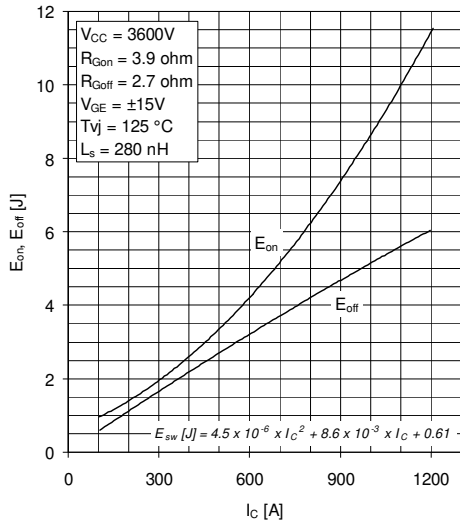

Fig. 7 Typical switching energies per pulse versus collector current

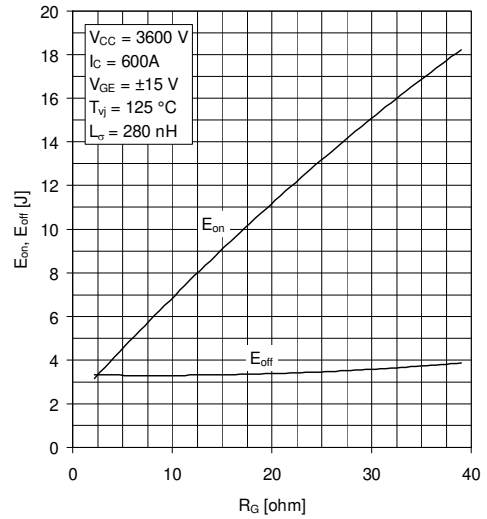

Fig. 8 Typical switching energies per pulse versus gate resistor

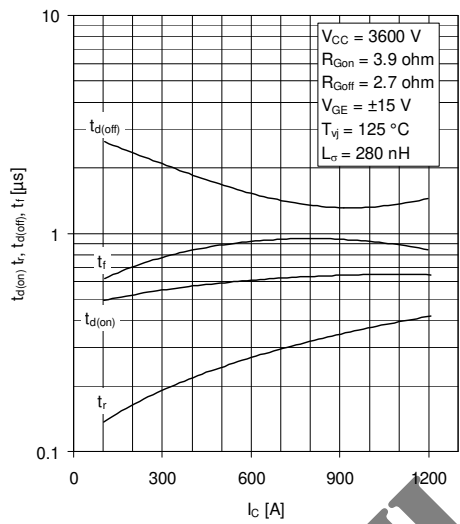

Fig. 9 Typical switching times vs. collector current

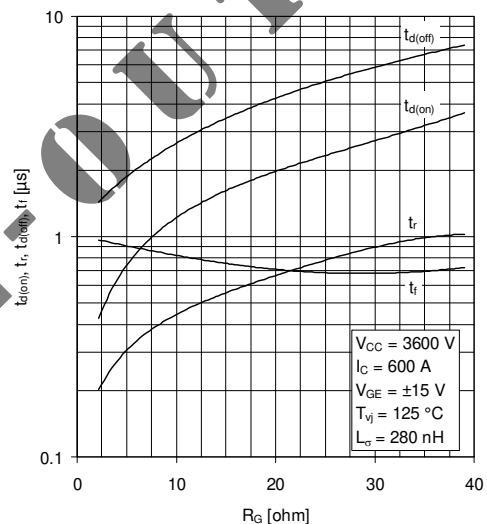

Fig. 10 Typical switching times vs. gate resistor

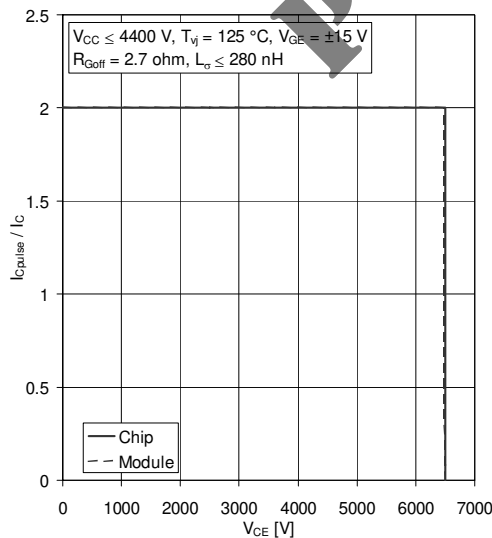

Fig. 11 Turn-off safe operating area (RBSOA)

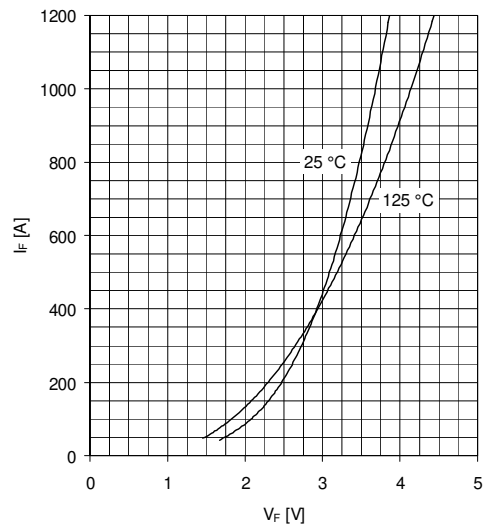

Fig. 12 Typ. diode forward characteristics, chip level

20110119a

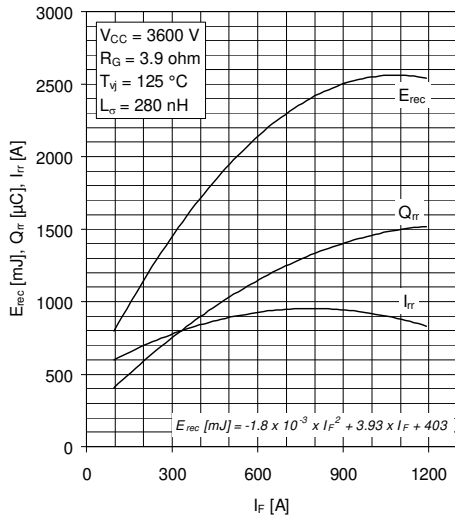

Fig. 13 Typ. reverse recovery characteristics versus forward current

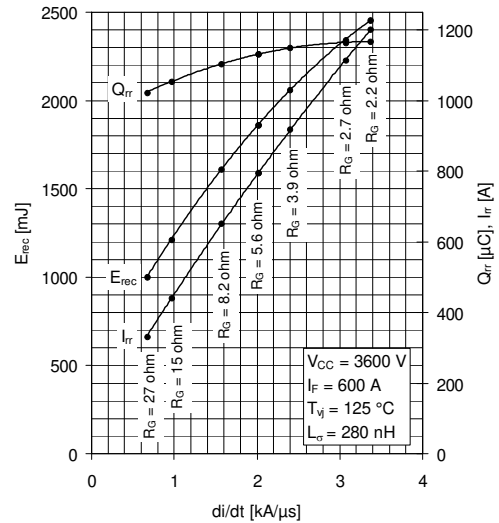

Fig. 14 Typ. reverse recovery characteristics versus di/dt

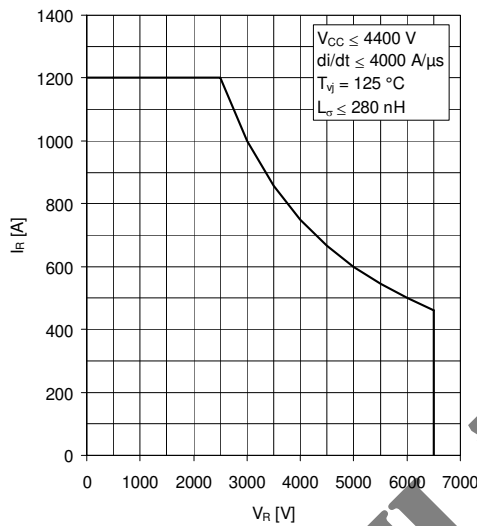

Fig. 15 Safe operating area diode (SOA)

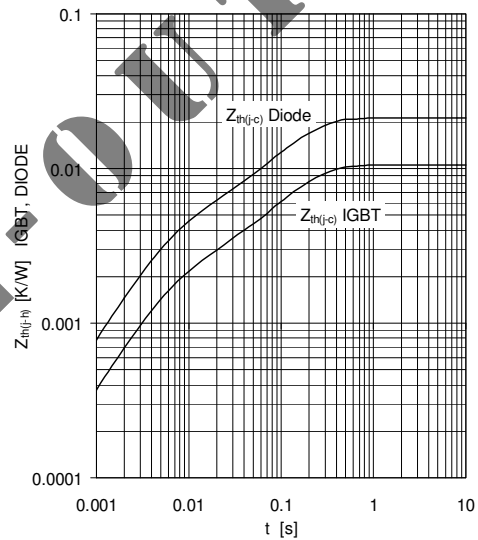
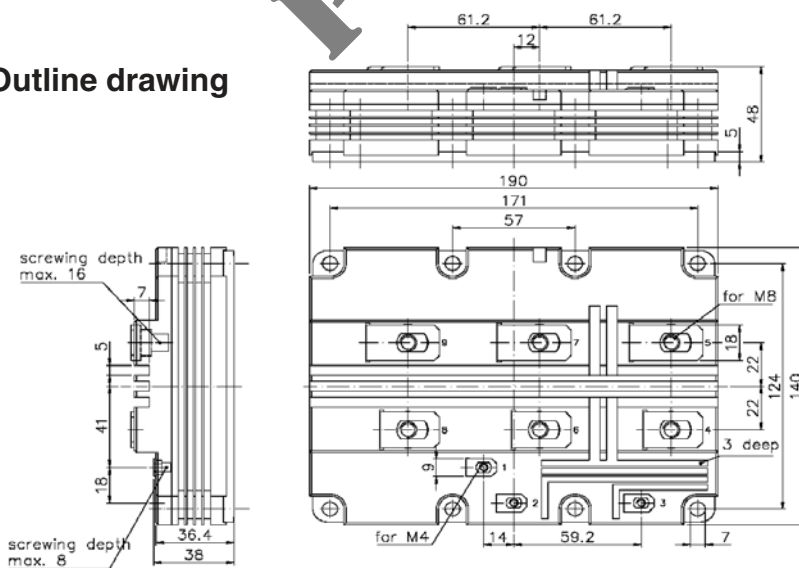

Fig. 16 Thermal impedance vs. time

**Outline drawing**



$$Z_{th(j-c)}(t) = \sum_{i=1}^n R_i (1 - e^{-t/\tau_i})$$

	i	1	2
IGBT	$R_i$ [K/kW]	8.5	2
	$t_i$ [ms]	151	5.84
DIODE	$R_i$ [K/kW]	17	4.2
	$t_i$ [ms]	144	5.83