

REVISIONS						
LOC	DIST	P	LTR	DESCRIPTION	DATE	APVD
-	-	NC		NEW RELEASE PER E.O. A7582	28JAN1988	JRA
		A		REVISED AND REDRAWN PER E.O. P16296	20SEP1999	RDR
		B		REVISED PER E.O. P21366	4JUN2012	RDR
		B1		REVISED PER ECO-14-002953	29JAN2014	PV DM

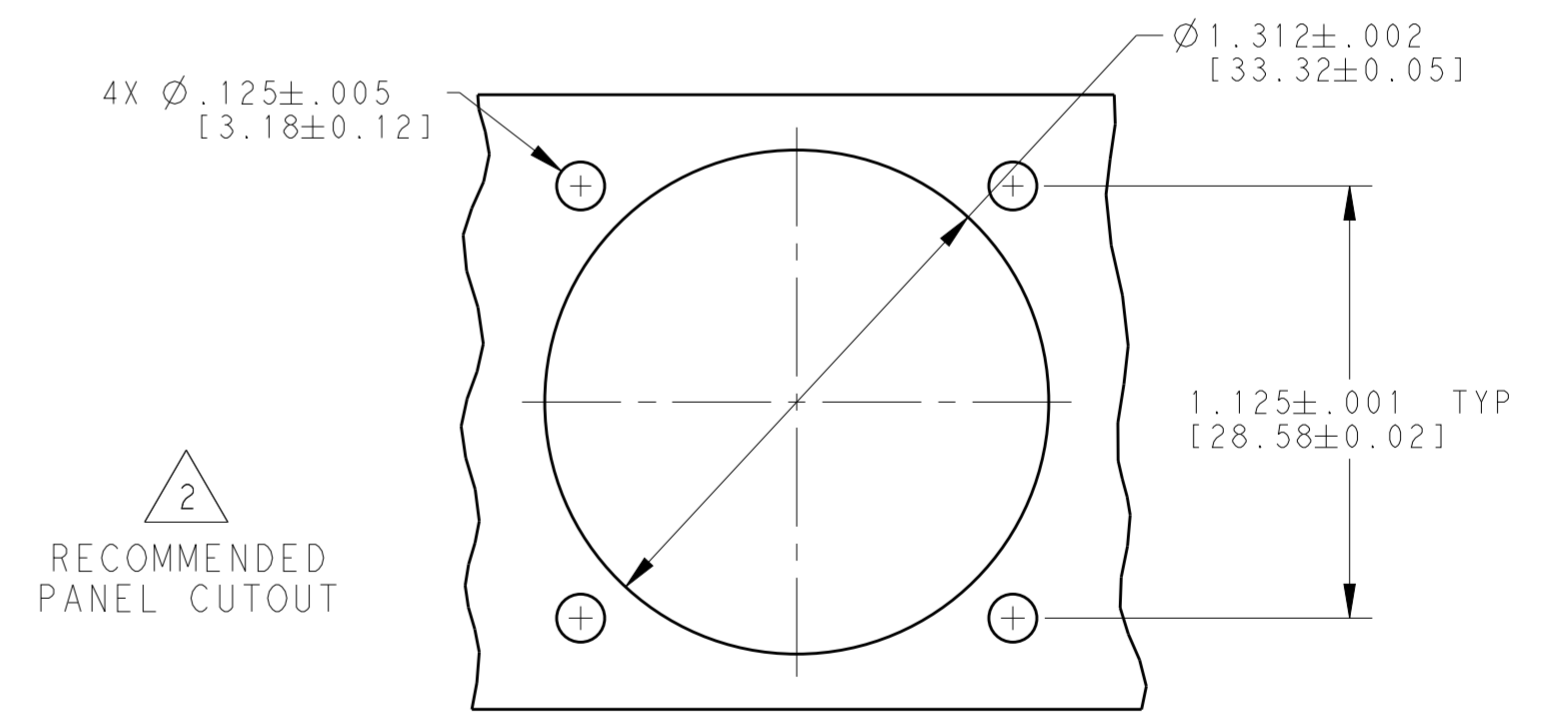
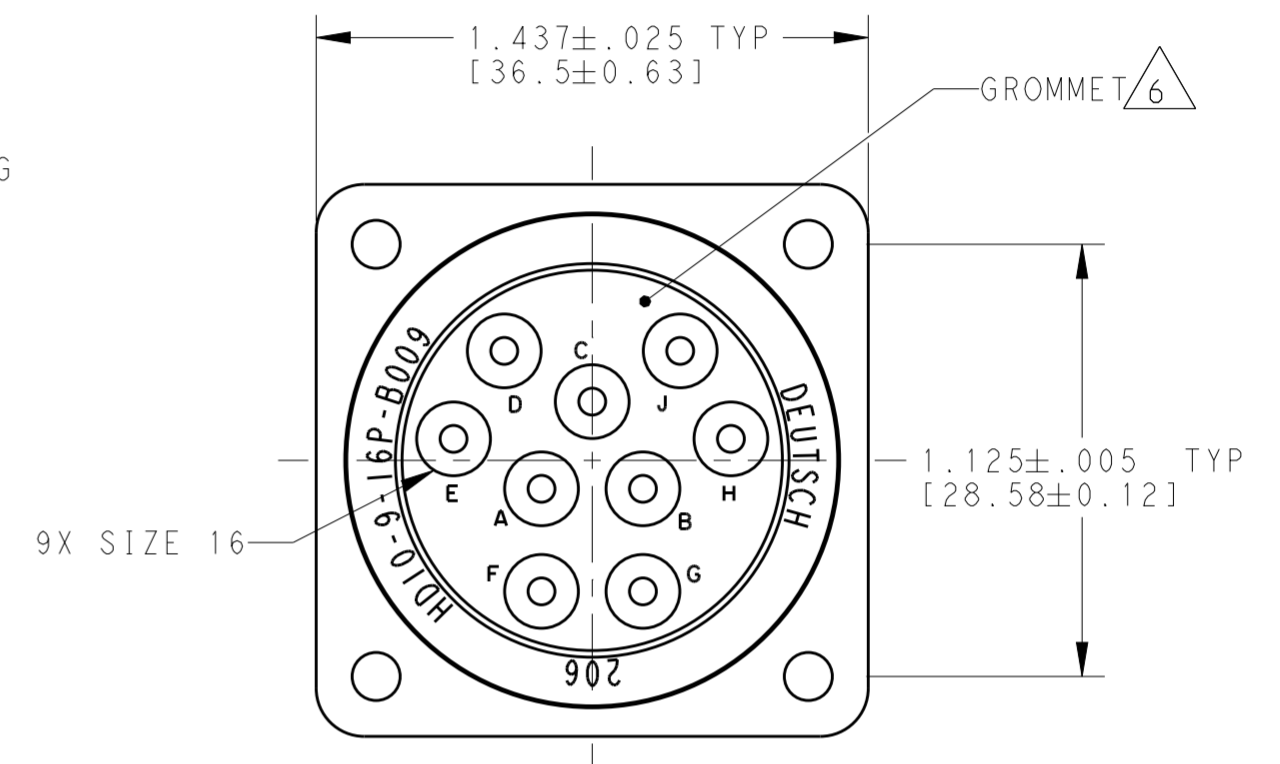
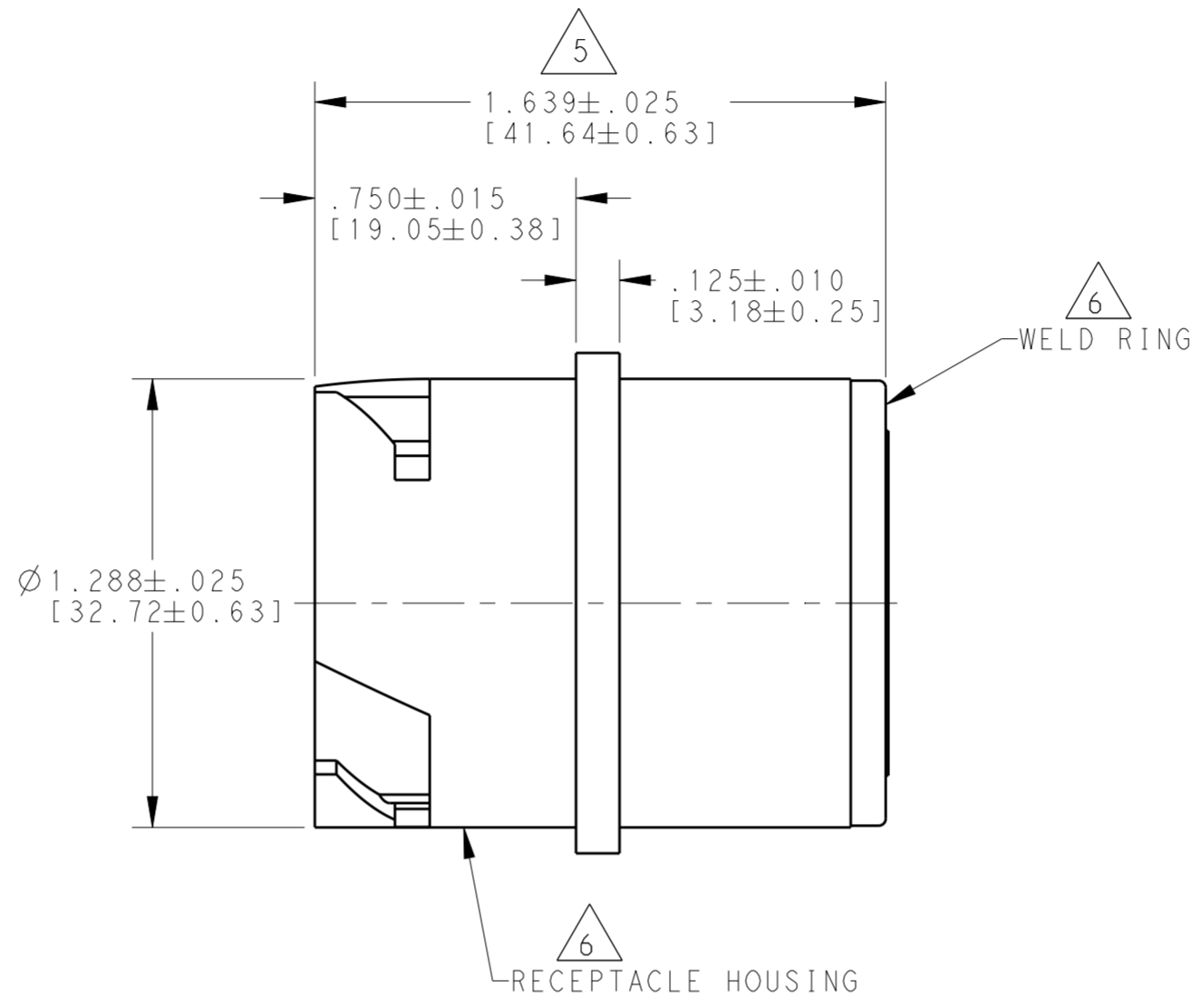
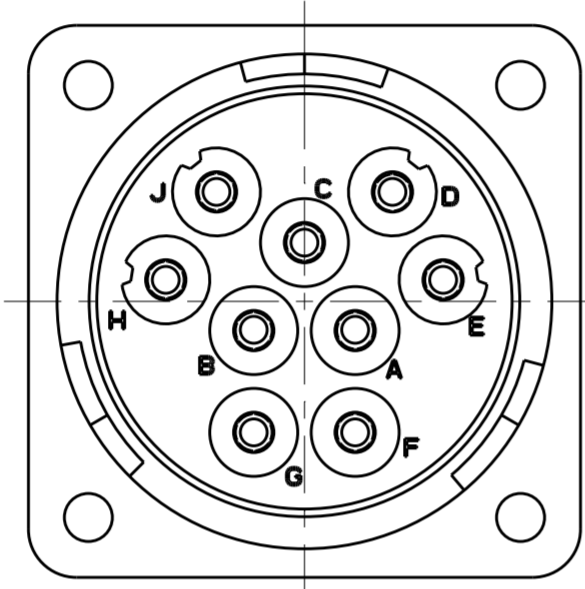
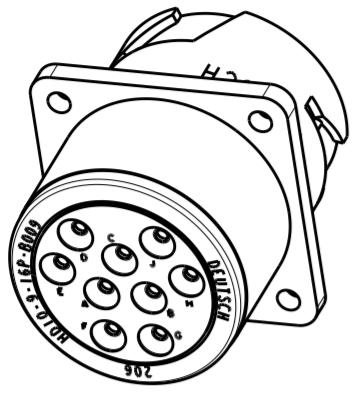

- 6. MATERIAL:
 RECEPTACLE HOUSING AND WELD RING; PA 15%GF (GREY)
 GROMMET: SILICONE (RED)
- 5. OVERALL DIMENSION DOES NOT INCLUDE RUBBER GROMMET.
- 4. THIS RECEPTACLE MATES WITH FOLLOWING PLUG (X=SEAL TYPE, XXXX= ALL MODIFICATIONS).
 HD16-9-16SX-XXXX
- 3. SEE DRAWING 0425-015-0000 FOR CONTACT AND WIRE PERFORMANCE AND APPLICATION CHARACTERISTICS.
- 2. MAXIMUM PANEL THICKNESS IS .250 [6.35].
- 1. SEE TABLE FOR USABLE WIRE RANGE AND INSULATION RANGES:

CONTACT SIZE	MIN. INSUL O.D.	MAX. INSUL O.D.	WIRE RANGE [mm ²]
16	.100 [2.45]	.150 [3.81]	14-20 AWG [2.0-.50]

NOTES:

THIS DRAWING IS A CONTROLLED DOCUMENT.

DIMENSIONS: INCHES [mm]	TOLERANCES UNLESS OTHERWISE SPECIFIED: 0 PLC ± 1 PLC ± 2 PLC ± 3 PLC ±.025 4 PLC ± ANGLES ±0° 30' 0" FINISH	DWN: D. SPENCER 02SEP1999 CHK: I. GRANTCHAROVA 16SEP2013 APVD: D. MEYER 18SEP2013	NAME: RECEPTACLE SQUARE FLANGE HD10 SERIES ARR. 9-16 COLOUR: GREY
MATERIAL: 6	PRODUCT SPEC: - APPLICATION SPEC: - WEIGHT: 37.40 (g)	SIZE: A2 CAGE CODE: 00779 DRAWING NO: HD10-9-16P-B009	RESTRICTED TO: -

Customer Drawing SCALE: 2:1 SHEET 1 OF 1 REV: B1