

THIS COPY IS PROVIDED ON A RESTRICTED BASIS AND IS NOT TO BE USED IN ANY WAY DETRIMENTAL TO THE INTERESTS OF PANDUIT CORP.

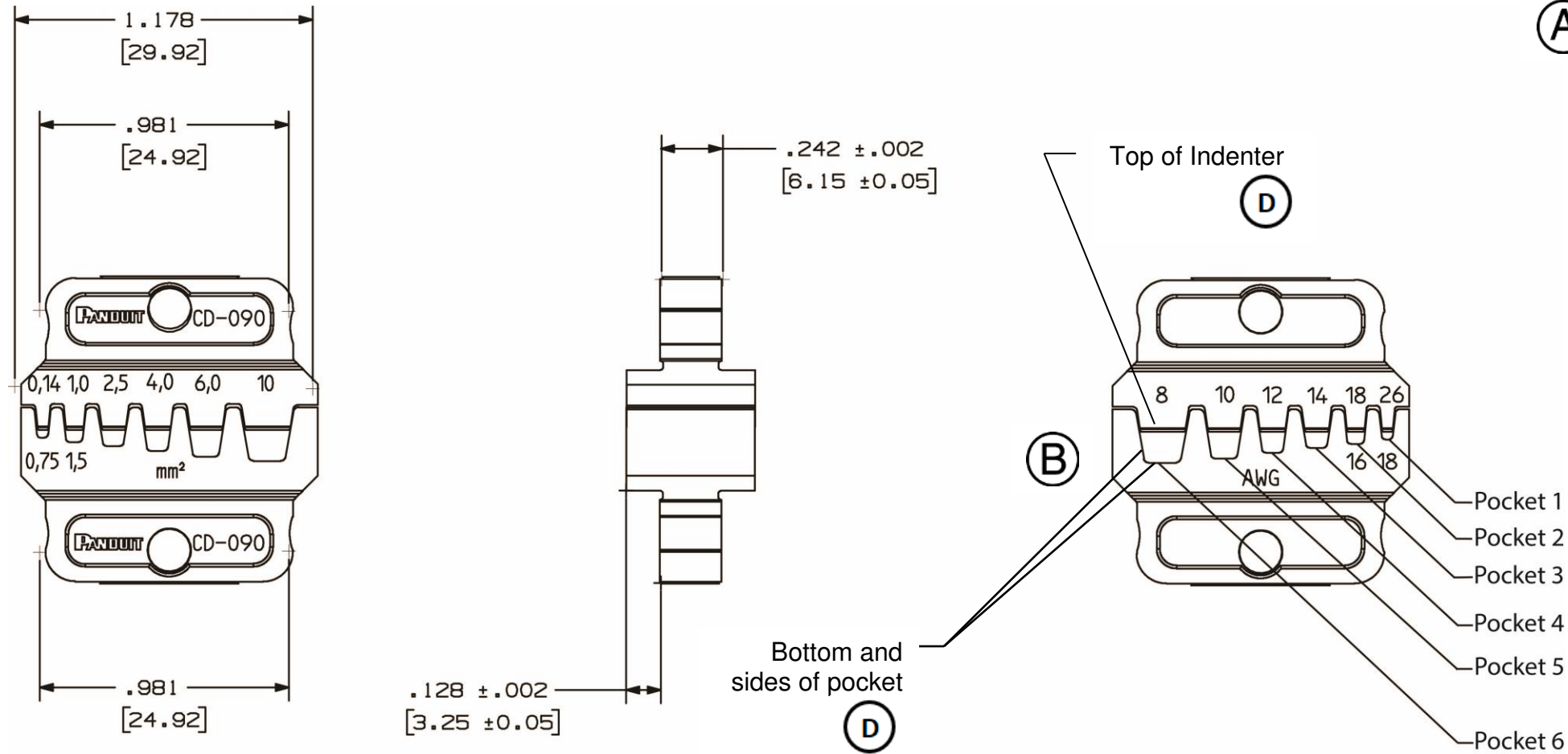

NOTES, UNLESS OTHERWISE SPECIFIED:

- Interchangeable Crimp Die Inserts used with CT-2500CH Crimp Head frame and CT-2300 Micro Crimp Tool to crimp Panduit #26 - 8 AWG (0,14 – 10,0mm²) insulated and non-insulated single wire ferrules and #22 - 12 AWG (0,05 – 4,0mm²) insulated twin ferrules with a square profile
- Laser etched as shown
- Bottom and sides of pockets and top of indenters polished

(D)

WEIGHT: 4.3 oz. [0.12] kg

DIMENSIONS SHOWN ARE FOR REFERENCE ONLY.

DIMENSIONS IN BRACKETS [MM] ARE METRIC.

CD-090 CRIMP POCKET	ENGLISH GO / NO GO GAGE MEMBERS		METRIC GO / NO GO GAGE MEMBERS	
	"G" Dia. (GO)	"NG" Dia. (NO GO)	"G" Dia. (GO)	"NG" Dia. (NO GO)
1	0.018"	0.026"	0,45mm	0,65mm
2	0.035"	0.043"	0,90mm	1,10mm
3	0.051"	0.059"	1,30mm	1,50mm
4	0.071"	0.079"	1,80mm	2,00mm
5	0.093"	0.104"	2,35mm	2,55mm
6	0.110"	0.118"	2,80mm	3,00mm

CROSS SECTION		
PROFILE	mm ²	AWG
1	0,14 – 0,75	22 - 18
2	1,0 – 1,5	18 – 16
3	2,5	14
4	4,0	12
5	6,0	10
6	10,0	8

(C)

File Location: Teamcenter

							CD-090 DIE SET			
							CUSTOMER DRAWING			
02	5-22-19	BWG	<i>BJPU</i>	<i>JADE</i>	(D) ADDED POLISH AND LASER NOTES AND INDICATED POCKET AND INDENTER.	10220/01	ITEM REVISION NAME: TF28309B01_02			
01	3-15-18	BLR	<i>BJPU</i>	<i>JADE</i>	(A) WAS 26-10(0,14-6,0); (B) ADD	20454	PANDUIT MATERIAL: _____ DRAWING NUMBER: TF28309B01			
----	----	----	----	----	AWG/SIZE LASER ETCH; (C) ADD	----			UNLESS OTHERWISE SPECIFIED, DIMENSIONAL TOLERANCES ARE: (.x) ± --- (.xxx) ± --- (.xx) ± --- ANGLES ± ---	
----	----	----	----	----	AWG COLUMN	----			THIRD ANGLE PROJECTION	
00	11-22-16	BLR	<i>BJPU</i>	<i>JADE</i>	RELEASED	11042				