

FEATURES

- 10 years minimum data retention in the absence of external power
- Data is automatically protected during power loss
- Directly replaces 2k x 8 volatile static RAM or EEPROM
- Unlimited write cycles
- Low-power CMOS
- JEDEC standard 28-pin DIP package
- Read and write access times as fast as 150 ns
- Full $\pm 10\%$ operating range
- Optional industrial temperature range of -40°C to $+85^{\circ}\text{C}$, designated IND

PIN ASSIGNMENT

NC	1	28	VCC
A12	2	27	$\overline{\text{WE}}$
A7	3	26	NC
A6	4	25	A8
A5	5	24	A9
A4	6	23	A11
A3	7	22	$\overline{\text{OE}}$
A2	8	21	A10
A1	9	20	$\overline{\text{CE}}$
A0	10	19	DQ7
DQ0	11	18	DQ6
DQ1	12	17	DQ5
DQ2	13	16	DQ4
GND	14	15	DQ3

24-Pin ENCAPSULATED PACKAGE
720-mil EXTENDED

PIN DESCRIPTION

A0-A12	- Address Inputs
DQ0-DQ7	- Data In/Data Out
$\overline{\text{CE}}$	- Chip Enable
$\overline{\text{WE}}$	- Write Enable
$\overline{\text{OE}}$	- Output Enable
V _{CC}	- Power (+5V)
GND	- Ground

DESCRIPTION

The DS1225Y 64k Nonvolatile SRAM is a 65,536-bit, fully static, nonvolatile RAM organized as 8192 words by 8 bits. Each NV SRAM has a self-contained lithium energy source and control circuitry which constantly monitors V_{CC} for an out-of-tolerance condition. When such a condition occurs, the lithium energy source is automatically switched on and write protection is unconditionally enabled to prevent data corruption. The NV SRAM can be used in place of existing 8k x 8 SRAMs directly conforming to the popular byte-wide 28-pin DIP standard. The DS1225Y also matches the pinout of the 2764 EPROM or the 2864 EEPROM, allowing direct substitution while enhancing performance. There is no limit on the number of write cycles that can be executed and no additional support circuitry is required for micro-processor interfacing.

READ MODE

The DS1225Y executes a read cycle whenever \overline{WE} (Write Enable) is inactive (high) and \overline{CE} (Chip Enable) and \overline{OE} (Output Enable) are active (low). The unique address specified by the 13 address inputs (A_0 - A_{12}) defines which of the 8192 bytes of data is to be accessed. Valid data will be available to the eight data output drivers within t_{ACC} (Access Time) after the last address input signal is stable, providing that \overline{CE} and \overline{OE} access times are also satisfied. If \overline{CE} and \overline{OE} access times are not satisfied, then data access must be measured from the later-occurring signal and the limiting parameter is either t_{CO} for \overline{CE} or t_{OE} for \overline{OE} rather than address access.

WRITE MODE

The DS1225Y executes a write cycle whenever the \overline{WE} and \overline{CE} signals are active (low) after address inputs are stable. The later-occurring falling edge of \overline{CE} or \overline{WE} will determine the start of the write cycle. The write cycle is terminated by the earlier rising edge of \overline{CE} or \overline{WE} . All address inputs must be kept valid throughout the write cycle. \overline{WE} must return to the high state for a minimum recovery time (t_{WR}) before another cycle can be initiated. The \overline{OE} control signal should be kept inactive (high) during write cycles to avoid bus contention. However, if the output drivers are enabled (\overline{CE} and \overline{OE} active) then \overline{WE} will disable the outputs in t_{ODW} from its falling edge.

DATA RETENTION MODE

The DS1225Y provides full functional capability for V_{CC} greater than 4.5 volts and write protects at 4.25 nominal. Data is maintained in the absence of V_{CC} without any additional support circuitry. The DS1225Y constantly monitors V_{CC} . Should the supply voltage decay, the NV SRAM automatically write protects itself, all inputs become “don’t care,” and all outputs become high impedance. As V_{CC} falls below approximately 3.0 volts, a power switching circuit connects the lithium energy source to RAM to retain data. During power-up, when V_{CC} rises above approximately 3.0 volts, the power switching circuit connects external V_{CC} to RAM and disconnects the lithium energy source. Normal RAM operation can resume after V_{CC} exceeds 4.5 volts.

ABSOLUTE MAXIMUM RATINGS*

Voltage on Any Pin Relative to Ground	-0.3V to +7.0V
Operating Temperature	0°C to 70°C; -40°C to +85°C for IND parts
Storage Temperature	-40°C to +70°C; -40°C to +85°C for IND parts
Soldering Temperature	+260°C for 10 seconds
Caution: Do Not Reflow	(Wave or Hand Solder Only)

* This is a stress rating only and functional operation of the device at these or any other conditions above those indicated in the operation sections of this specification is not implied. Exposure to absolute maximum rating conditions for extended periods of time may affect reliability.

RECOMMENDED DC OPERATING CONDITIONS(T_A : See Note 10)

PARAMETER	SYMBOL	MIN	TYP	MAX	UNITS	NOTES
Power Supply Voltage	V _{CC}	4.5	5.0	5.5	V	
Input Logic 1	V _{IH}	2.2		V _{CC}	V	
Input Logic 0	V _{IL}	0.0		+0.8	V	

DC ELECTRICAL CHARACTERISTICS(T_A : See Note 10; V_{CC} = 5V ± 10%)

PARAMETER	SYMBOL	MIN	TYP	MAX	UNITS	NOTES
Input Leakage Current	I _{IL}	-1.0		+1.0	μA	
I/O Leakage Current $\overline{CE} \geq V_{IH} \leq V_{CC}$	I _{IO}	-1.0		+1.0	μA	
Output Current @ 2.4V	I _{OH}	-1.0			mA	
Output Current @ 0.4V	I _{OL}	2.0			mA	
Standby Current $\overline{CE} = 2.2V$	I _{CCS1}		5	10	mA	
Standby Current $\overline{CE} = V_{CC} - 0.5V$	I _{CCS2}		3	5	mA	
Operating Current t _{CYC} = 200ns (Commercial)	I _{CCO1}			75	mA	
Operating Current t _{CYC} = 200ns (Industrial)	I _{CCO1}			85	mA	
Write Protection Voltage	V _{TP}		4.25		V	10

AC ELECTRICAL CHARACTERISTICS (t_A : See Note 10; $V_{CC} = 5.0V \pm 10\%$)

PARAMETER	SYMBOL	DS1225Y-150		DS1225Y-170		DS1225Y-200		UNITS	NOTES
		MIN	MAX	MIN	MAX	MIN	MAX		
Read Cycle Time	t_{RC}	150		170		200		ns	
Access Time	t_{ACC}		150		170		200	ns	
\overline{OE} to Output Valid	t_{OE}		70		80		100	ns	
\overline{CE} to Output Valid	t_{CO}		150		170		200	ns	
\overline{OE} or \overline{CE} to Output Active	t_{COE}	5		5		5		ns	5
Output High Z from Deselection	t_{OD}		35		35		35	ns	5
Output Hold from AddressChange	t_{OH}	5		5		5		ns	
Write Cycle Time	t_{WC}	150		170		200		ns	
Write Pulse Width	t_{WP}	100		120		150		ns	3
Address Setup Time	t_{AW}	0		0		0		ns	
Write Recovery Time	t_{WR1}	0		0		0		ns	12
	t_{WR2}	10		10		10		ns	13
Output High Z from \overline{WE}	t_{ODW}		35		35		35	ns	5
Output Active from \overline{WE}	t_{OEW}	5		5		5		ns	5
Data Setup Time	t_{DS}	60		70		80		ns	4
Data Hold Time	t_{DH1}	0		0		0		ns	12
	t_{DH2}	10		10		10		ns	13

CAPACITANCE $(T_A = 25^\circ C)$

PARAMETER	SYMBOL	MIN	TYP	MAX	UNITS	NOTES
Input Capacitance	C_{IN}			10	pF	
Input/Output Capacitance	$C_{I/O}$			10	pF	

READ CYCLE

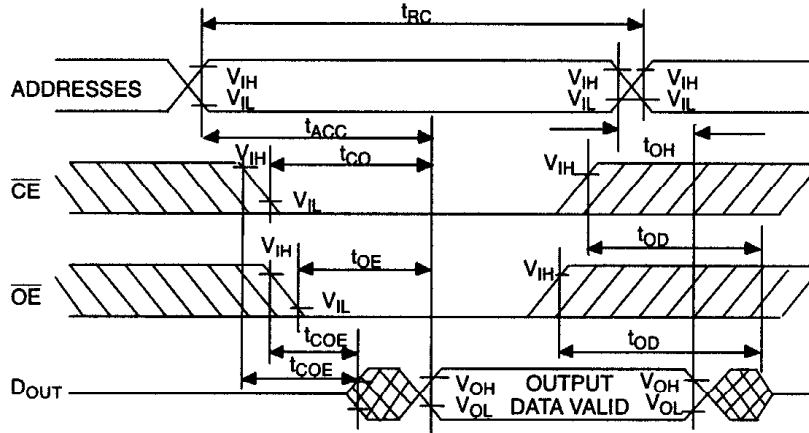

SEE NOTE 1

WRITE CYCLE 1

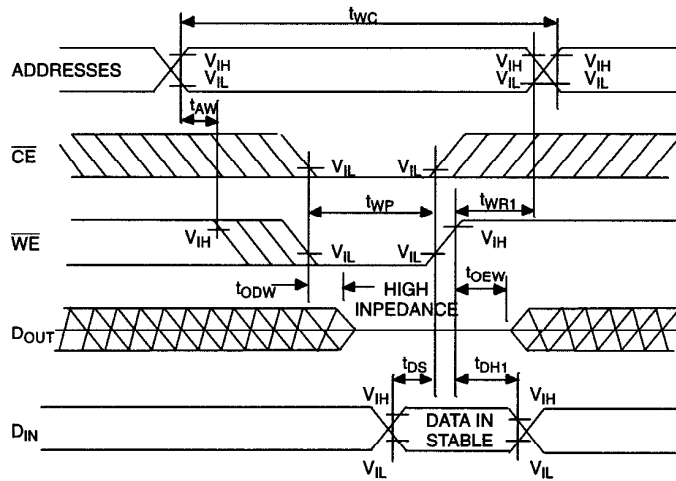

SEE NOTE 2, 3, 4, 6, 7, 8 AND 12

WRITE CYCLE 2

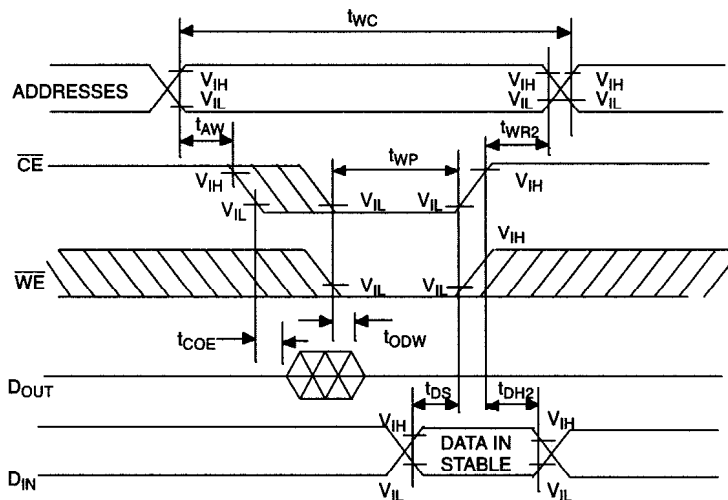

SEE NOTE 2, 3, 4, 6, 7, 8 AND 13

POWER-DOWN/POWER-UP CONDITION

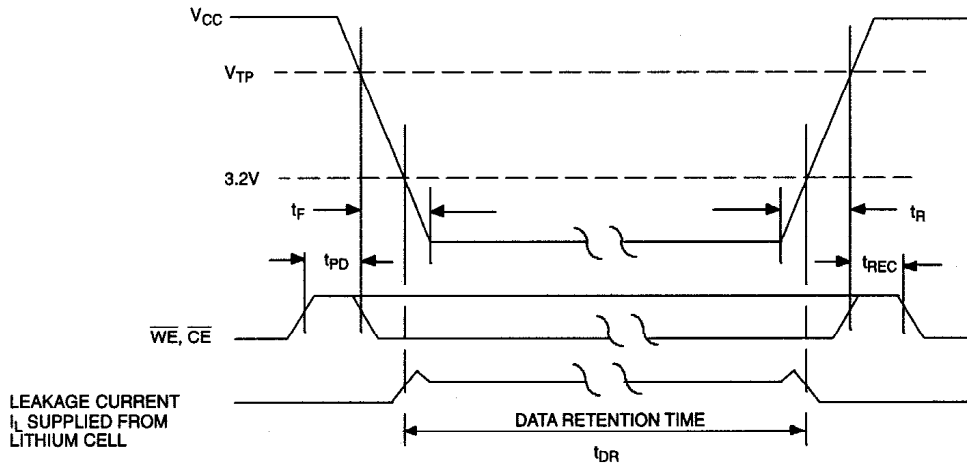

SEE NOTE 11

POWER-DOWN/POWER-UP TIMING

PARAMETER	SYMBOL	MIN	MAX	UNITS	NOTES
\overline{CE} at V_{IH} before Power-Down	t_{PD}	0		μs	11
V_{CC} Slew from V_{TP} to 0V	t_F	100		μs	
V_{CC} Slew from 0V to V_{TP}	t_R	0		μs	
\overline{CE} at V_{IH} after Power-Up	t_{REC}		2	ms	

 $(T_A = 25^\circ\text{C})$

PARAMETER	SYMBOL	MIN	MAX	UNITS	NOTES
Expected Data Retention Time	t_{DR}	10		years	9

WARNING:

Under no circumstance are negative undershoots, of any amplitude, allowed when device is in battery backup mode.

NOTES:

- \overline{WE} is high for a read cycle.
- $\overline{OE} = V_{IH}$ or V_{IL} . If $\overline{OE} = V_{IH}$ during a write cycle, the output buffers remain in a high impedance state.
- t_{WP} is specified as the logical AND of \overline{CE} and \overline{WE} . t_{WP} is measured from the latter of \overline{CE} or \overline{WE} going low to the earlier of \overline{CE} or \overline{WE} going high.
- t_{DS} is measured from the earlier of \overline{CE} or \overline{WE} going high.
- These parameters are sampled with a 5 pF load and are not 100% tested.
- If the \overline{CE} low transition occurs simultaneously with or later than the \overline{WE} low transition in Write Cycle 1, the output buffers remain in a high-impedance state during this period.
- If the \overline{CE} high transition occurs prior to or simultaneously with the \overline{WE} high transition, the output buffers remain in a high-impedance state during this period.

8. If \overline{WE} is low or the \overline{WE} low transition occurs prior to or simultaneously with the \overline{CE} low transition, the output buffers remain in a high-impedance state during this period.
9. Each DS1225Y is marked with a 4-digit date code AABB. AA designates the year of manufacture. BB designates the week of manufacture. The expected t_{DR} is defined as starting at the date of manufacture.
10. All AC and DC electrical characteristics are valid over the full operating temperature range. For commercial products, this range is 0°C to 70°C. For industrial products (IND), this range is -40°C to +85°C.
11. In a power down condition the voltage on any pin may not exceed the voltage on V_{CC} .
12. t_{WR1} , t_{DH1} are measured from \overline{WE} going high.
13. t_{WR2} , t_{DH2} are measured from \overline{CE} going high.
14. DS1225Y modules are recognized by Underwriters Laboratory (U.L.®) under file E99151 (R).

DC TEST CONDITIONS

Outputs open.

All voltages are referenced to ground.

AC TEST CONDITIONS

Output Load: 100pF + 1TTL Gate

Input Pulse Levels: 0-3.0V

Timing Measurement Reference Levels

Input: 1.5V Output: 1.5V

Input Pulse Rise and Fall Times: 5ns

ORDERING INFORMATION

PART NUMBER	TEMPERATURE RANGE	SUPPLY TOLERANCE	PIN/PACKAGE	SPEED GRADE
DS1225Y-150	0°C to +70°C	5V ± 10%	28 / 720 EMOD	150ns
DS1225Y-150+	0°C to +70°C	5V ± 10%	28 / 720 EMOD	150ns
DS1225Y-150IND	-40°C to +85°C	5V ± 10%	28 / 720 EMOD	150ns
DS1225Y-150IND+	-40°C to +85°C	5V ± 10%	28 / 720 EMOD	150ns
DS1225Y-170	0°C to +70°C	5V ± 10%	28 / 720 EMOD	170ns
DS1225Y-170+	0°C to +70°C	5V ± 10%	28 / 720 EMOD	170ns
DS1225Y-200	0°C to +70°C	5V ± 10%	28 / 720 EMOD	200ns
DS1225Y-200+	0°C to +70°C	5V ± 10%	28 / 720 EMOD	200ns
DS1225Y-200IND	-40°C to +85°C	5V ± 10%	28 / 720 EMOD	200ns
DS1225Y-200IND+	-40°C to +85°C	5V ± 10%	28 / 720 EMOD	200ns

+ Denotes lead(Pb)-free/RoHS-compliant product.

PACKAGE INFORMATION

For the latest package outline information and land patterns, go to <http://www.maxim-ic.com/packages>.

PACKAGE TYPE	PACKAGE CODE	DOCUMENT NO.
28 EDIP	MDT28+2	21-0245

REVISION HISTORY

REVISION DATE	DESCRIPTION	PAGES CHANGED
121907	Added package information table. Removed the DIP module package drawing and dimension table.	7