

REVISIONS					
P	LTR	DESCRIPTION	DATE	DWN	APVD
R		REVISED PER ECO-21-006874	29SEP2021	RK	MZ

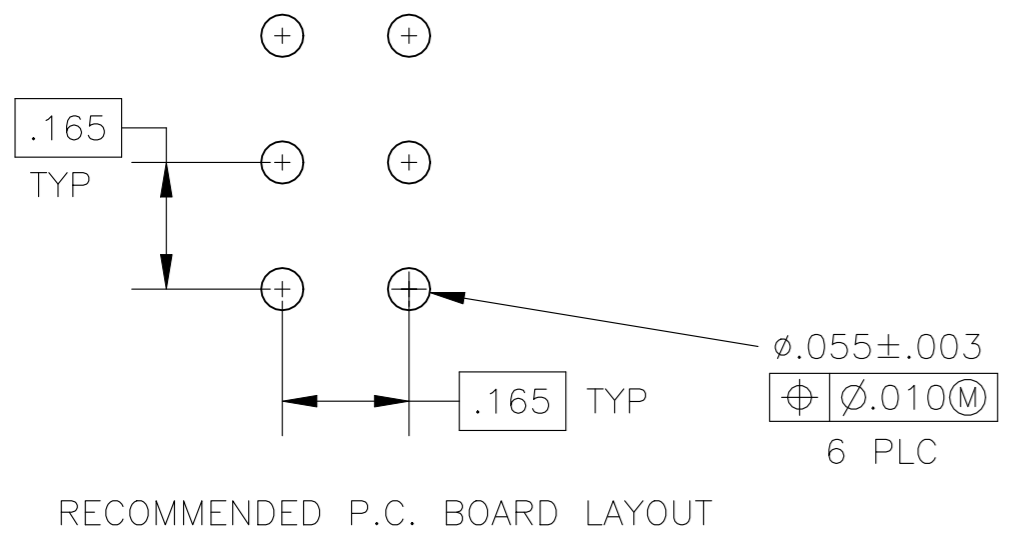
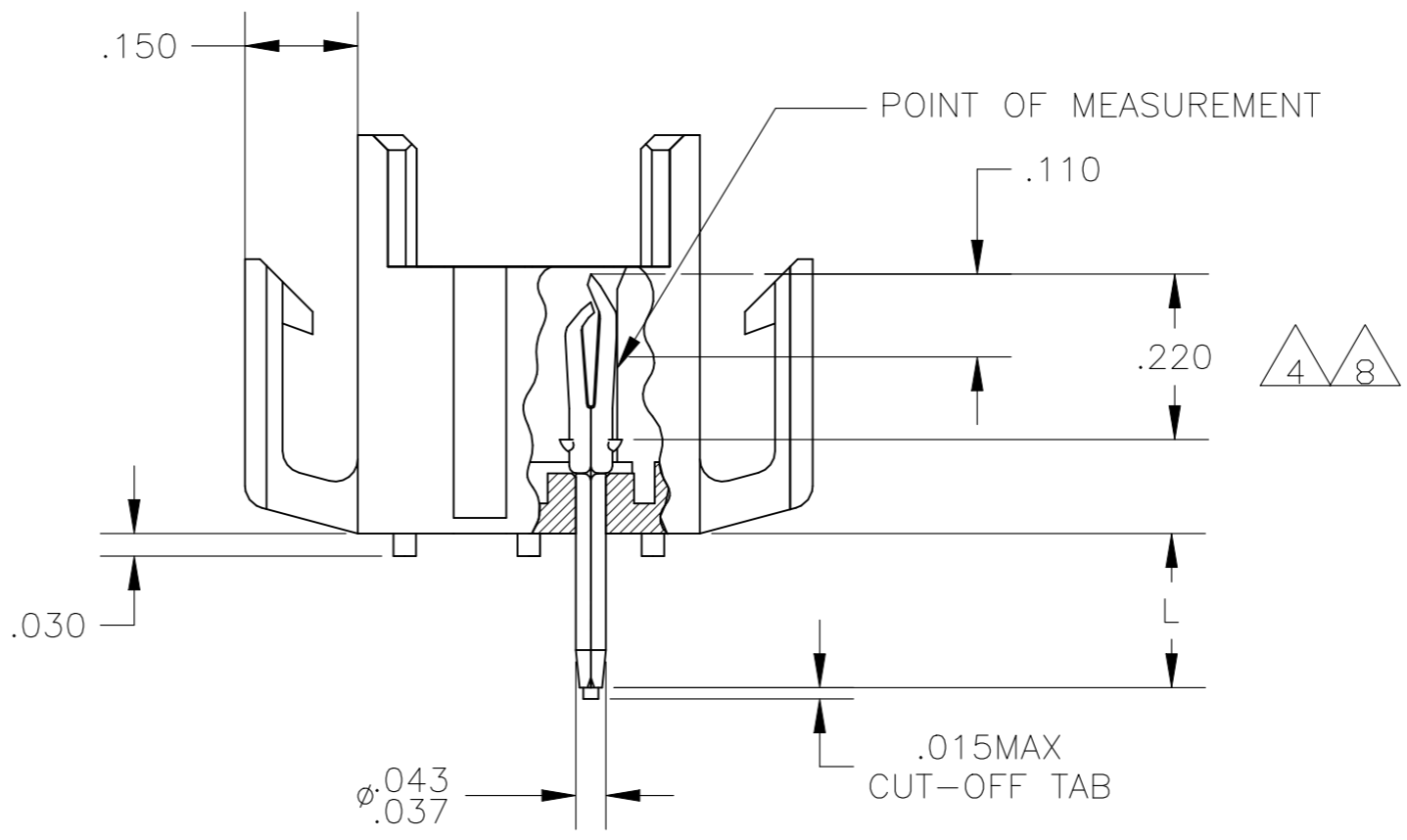
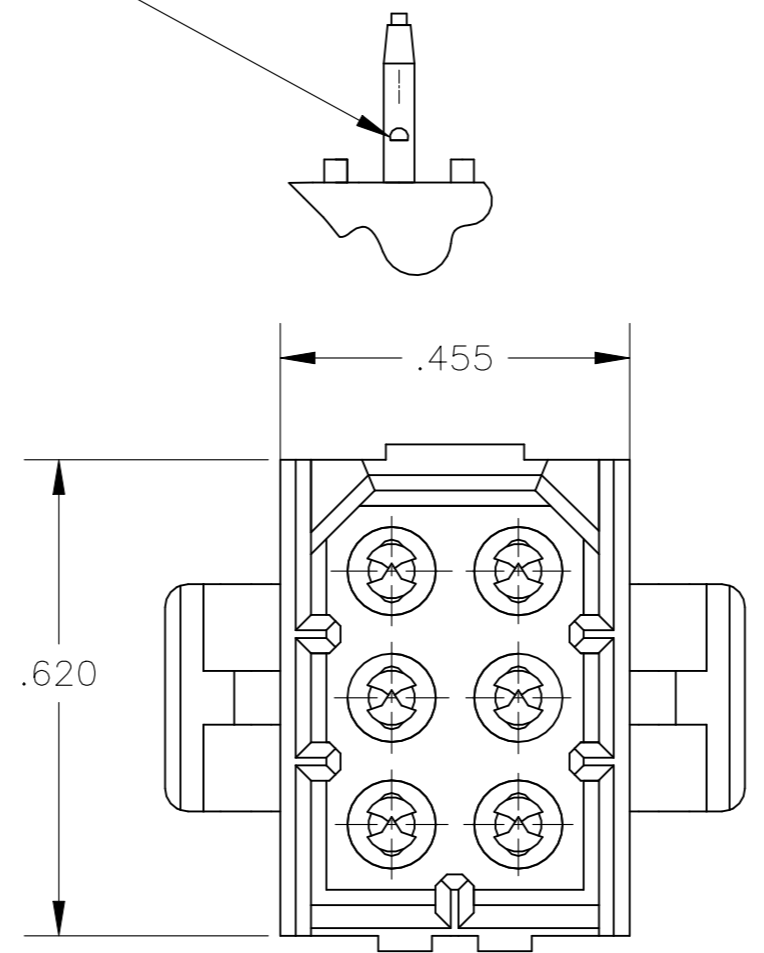
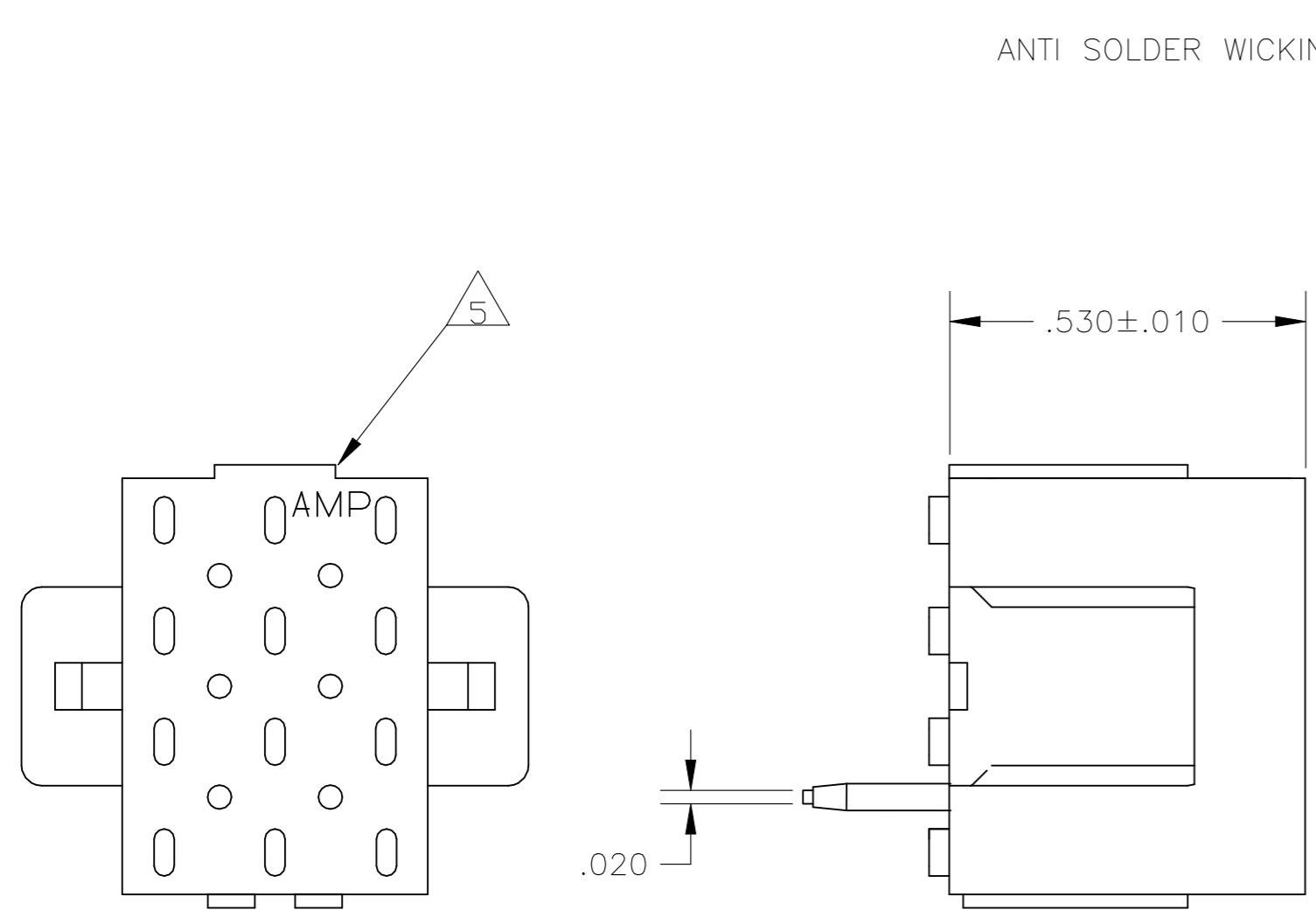

- 1 FITS SOCKET HOUSING 640520.
- 2 ASSEMBLY CONFORMS TO AMP SOLDERABILITY SPEC. 109-11-3.
- 3 FOR USE WITH .063 THICK P.C. BOARD.
- 4 CONTACT IS PLATED OVERALL WITH .000050 NICKEL, THEN .000030 GOLD OVER CONTACT LENGTH INDICATED AND .000150 MATTE TIN-LEAD ON SOLDER TAIL END.
- 5 UL AND CSA LOGO LOCATED ON THIS SURFACE.
- 6 FOR USE WITH .120 THICK P.C. BOARD.
- 7 FOR USE WITH .093 THICK P.C. BOARD.
- 8 CONTACT IS PLATED OVERALL WITH .000050 NICKEL, THEN .000030 GOLD OVER CONTACT LENGTH INDICATED AND .000150 MATTE TIN ON SOLDER TAIL END.
- 9 HOUSING MATERIAL: PA66, BLACK, UL 94 V-0 RATED CONTACT MATERIAL: PHOSPHOR BRONZE

OBSOLETE	PLC	FINISH	PART NUMBER
	.180	GOLD	2-640500-6
	.210	GOLD	2-640500-4
	.150	GOLD	2-640500-2
	.180	GOLD	640500-6
	.180	PRE-TIN	640500-5
	.210	GOLD	640500-4
	.210	PRE-TIN	640500-3
	.150	GOLD	640500-2
	.150	PRE-TIN	640500-1
	"L" +.010 -.020	PIN FINISH	PART NUMBER

IN	MM	IN	MM	IN	MM	IN	MM
.010	0.25	.055	1.40	.210	5.33	-	-
.008	0.20	.043	1.09	.180	4.57	-	-
.005	0.13	.037	0.94	.165	4.19	.620	15.75
.003	0.08	.030	0.76	.150	3.81	.530	13.46
.000050	0.00127	.020	0.51	.110	2.79	.455	11.56
.000030	0.00076	.015	0.38	.063	1.60	.220	5.59
IN	MM	IN	MM	IN	MM	IN	MM

CONVERSION TABLE

THIS DRAWING IS A CONTROLLED DOCUMENT.

DWN: J. HUFFMAN 28APR98
 CHK: R. SWING 28APR98
 APVD: T. BEDDICK 28APR98

TE Connectivity

NAME: HEADER ASSEMBLY, PIN, 6 POSITION, MR.

SIZE: A2 CAGE CODE: 00779 DRAWING NO: C-640500 RESTRICTED TO: -

SCALE: 4:1 SHEET: 1 OF 1 REV: R

MATERIAL: PA66, BLACK, UL 94 V-0 RATED CONTACT MATERIAL: PHOSPHOR BRONZE

FINISH: SEE TABLE

TOLERANCES UNLESS OTHERWISE SPECIFIED:
 0 PLC ± -
 1 PLC ± -
 2 PLC ± -
 3 PLC ± .005
 4 PLC ± -
 ANGLES ± 0°30'