

REVISIONS					
P	LTR	DESCRIPTION	DATE	DWN	APVD
	A2	REV PER ECN-22-150900	28APR2022	RK	CSD

AMP
WIRE RANGE

12-10 AWG
STRANDED

- 1 WIRE INSULATION DIA .150 TO .220.
- 2 FINISH: BODY AND SLEEVE:
TIN PLATE PER ASTM B545.
- 3 MATERIAL: BODY AND SLEEVE,
COPPER PER ASTM B152
INSULATION: PVF²
COLOR- NATURAL

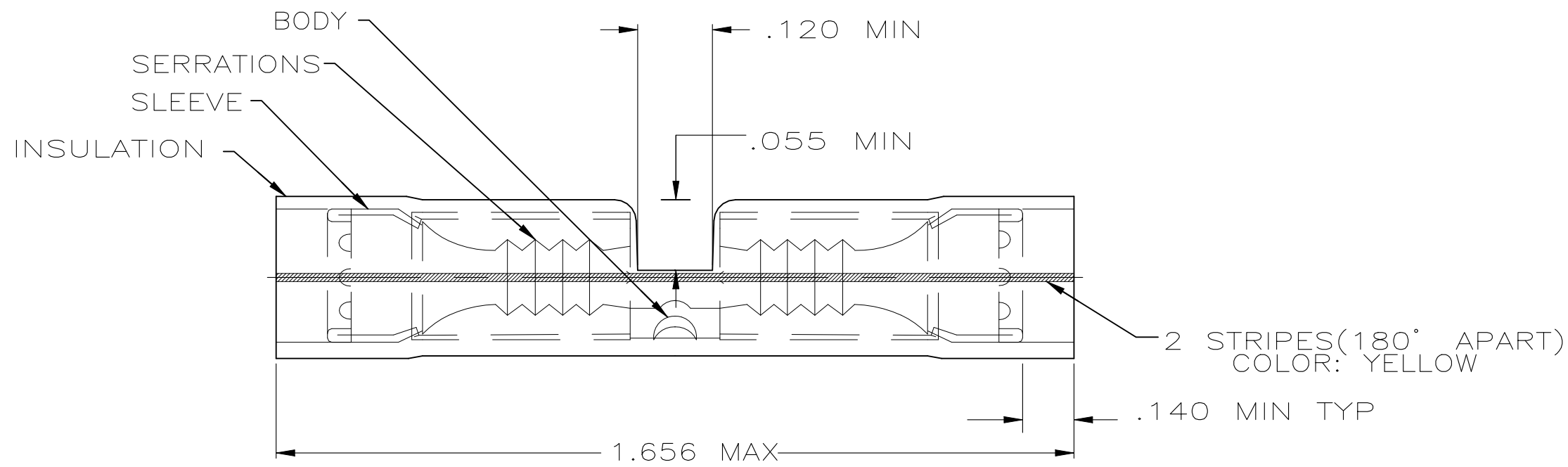

500	LOOSE PIECE	696429-1
QTY	PACKAGE TYPE	PART NO.

AMP INCORPORATED
CUSTOMER SERVICE SYSTEMS

FOR ADDITIONAL PRODUCT INFORMATION OR COPIES OF DRAWINGS AND TECHNICAL DOCUMENTS
PRODUCT INFORMATION CENTER
1-800-522-6752

FOR APPLICATION TOOLING INFORMATION
TOOLING ASSISTANCE CENTER
1-800-722-1111

FOR ORDER ENTRY
1-800-526-5142

MAX RECOMMENDED OPERATING TEMPERATURE:
150°C

VOLTAGE RATING:
-

CIRCULAR MIL AREA:
2.62-6.64mm² [5,180-13,100]
STRANDED

THIS DRAWING IS A CONTROLLED DOCUMENT.

DIMENSIONS: INCHES

TOLERANCES UNLESS OTHERWISE SPECIFIED:

0 PLC	± -
1 PLC	± -
2 PLC	± .008
3 PLC	± -
4 PLC	± -
ANGLES	± -

MATERIAL: - 3

FINISH: - 2

DWN: JR RUTH 19AUG05
CHK: T MICHELUTTI 19AUG05
APVD: T MICHELUTTI 19AUG05

PRODUCT SPEC: -
APPLICATION SPEC: -
WEIGHT: -

STE TE Connectivity

NAME: SPLICE, BUTT, PVF2 , P.I.D.G.
WIRE SIZE: 12-10 AWG

SIZE	CAGE CODE	DRAWING NO	RESTRICTED TO
A3	00779	C-696429	-

CUSTOMER DRAWING SCALE: 1:1 SHEET: 1 OF 1 REV: A2