

© 1963 BY AMP INCORPORATED. ALL RIGHTS RESERVED. AMP PRODUCTS COVERED BY PATENTS AND/OR PATENTS PENDING.

REVISIONS				
SYM	ZONE	DESCRIPTION	DATE	APPROVAL
N		REV PER ECO-09-021304	PY 10-09	DE

NUMBER 202287

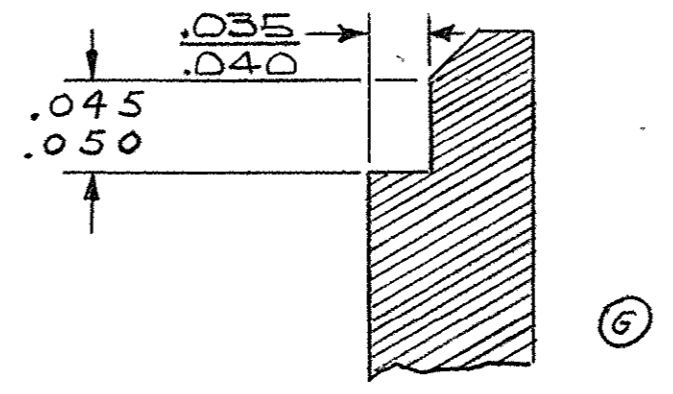
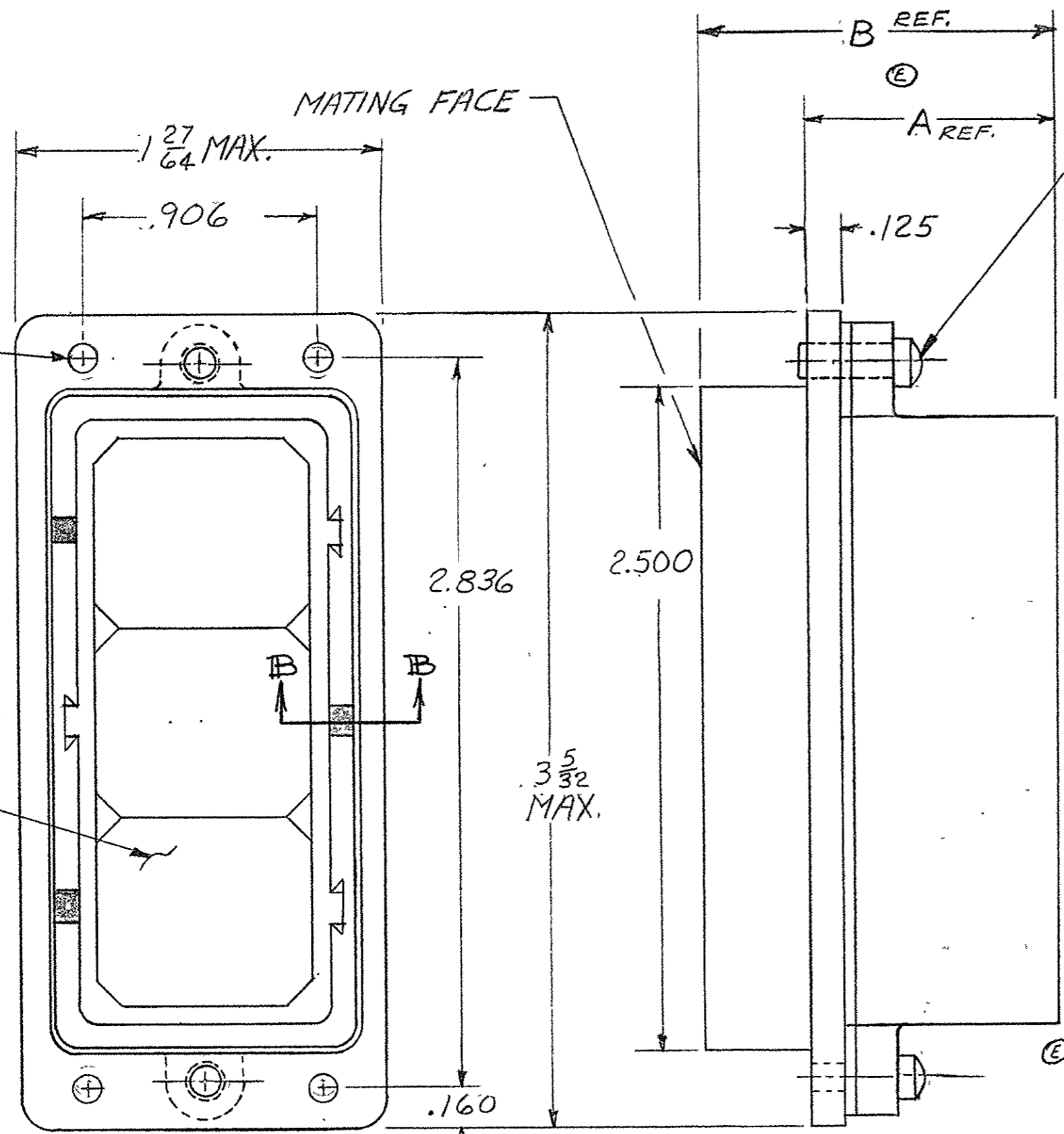

SECTION B-B  
SCALE: 10-1

ASSY. NO	A	B	FINISH
202287-1 SUPERSEDED BY 5--1	1.001	1.509	ZINC PLATE PER ASTM-B-639 TYPE II CLASS 3 COLORLESS SUPPLEMENTARY CHROMATE
202287-2	1.001	1.509	OLIVE DRAB ZINC PLATE PER ASTM-B-639 CLASS 3 TYPE II
202287-3 SUPERSEDED BY 5--3	1.001	1.509	FINISH SAME AS -1
202287-4 SUPERSEDED BY 5--4	.595	1.103	FINISH SAME AS -1
5-202287-1	1.001	1.509	FINISH: PLATED ELECTROLESS NICKEL PER SAE-AMS-C-2607A .000400-.000800 THK (NO INTENTIONAL ADDITIONS OF LEAD OR CHROMIUM PER DFE STD 230-700)
5-202287-3	1.001	1.509	FINISH: PLATED ELECTROLESS NICKEL PER SAE-AMS-C-2607A .000400-.000800 THK (NO INTENTIONAL ADDITIONS OF LEAD OR CHROMIUM PER DFE STD 230-700)
5-202287-4	.595	1.103	FINISH: PLATED ELECTROLESS NICKEL PER SAE-AMS-C-2607A .000400-.000800 THK (NO INTENTIONAL ADDITIONS OF LEAD OR CHROMIUM PER DFE STD 230-700)

.125-.130  
DIA. HOLES

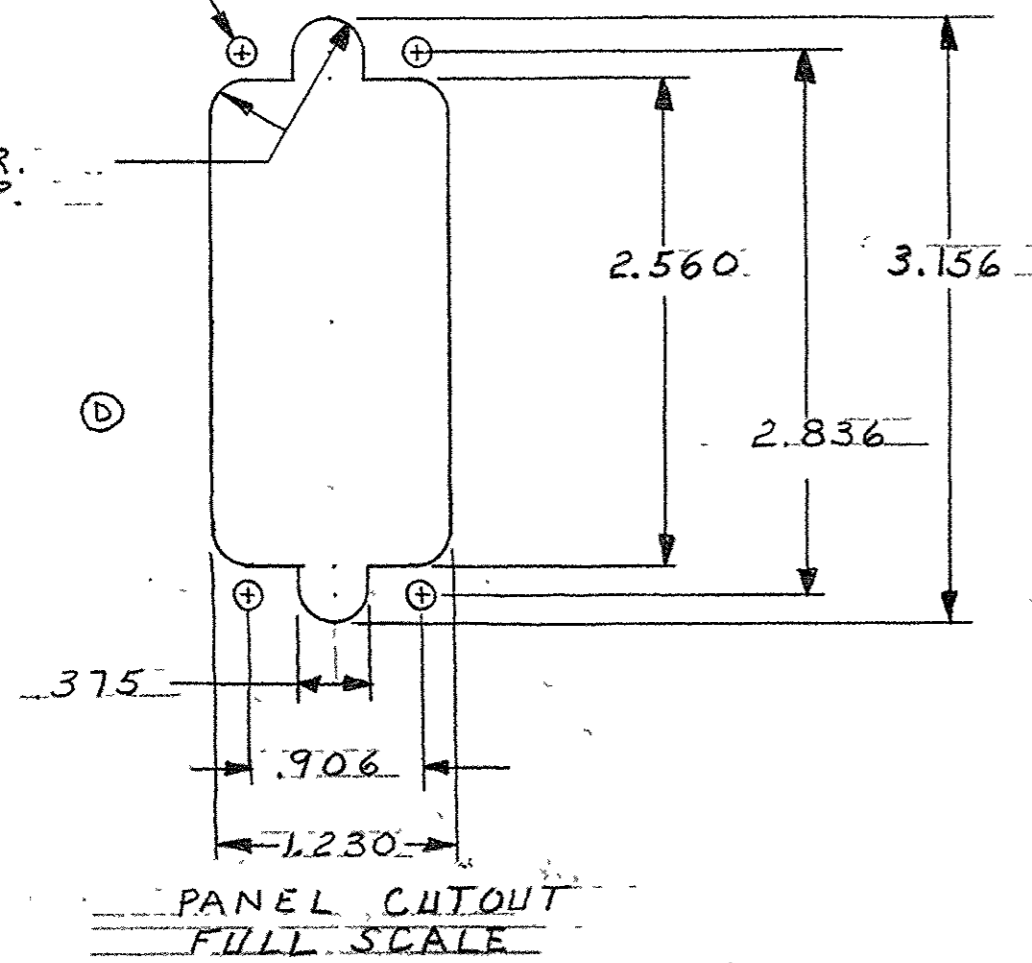

PANEL CUTOUT  
FULL SCALE

AMP INFO		QTY REQD	NOMENCLATURE OR DESCRIPTION	PART OR IDENTIFYING NO
LOC	PRINT DIST			
DF	M	30		
LIST OF MATERIALS OR PARTS LIST				
UNLESS OTHERWISE SPECIFIED DIMENSIONS ARE IN INCHES		SIGNATURE		DATE
FRACTIONS	DECIMALS	DR <i>D. Miller</i>		2-25-63
± 1/64	± .015	CHK <i>J. Kaufman</i>		4-12-63
ANGLES ± #		DSGN ENGR <i>J. Willyshaw</i>		3-1-63
MATERIAL		APPD <i>B. Curcio</i>		5/13/63
HEAT TREAT		DSGN APPD		
FINISH		OTHER APPD		
SEE TABLE				
AMP INCORPORATED HARRISBURG, PENNSYLVANIA			RECEPTACLE ASSEMBLY, MODULE SERIES "G"	
CODE IDENT NO		SIZE	NUMBER	REV
00779		C	202287	N
SCALE 2-1		WT	CALC	ACTUAL
				SHEET 1 OF 1

CUSTOMER DRAWING