



Digitized Automation for a Changing World

Delta Fan/Pump Vector Control Drive CP2000 Series



www.deltaww.com

 **DELTA**
Smarter. Greener. Together.

WHY CP2000?

Delta Industrial Automation Green Technology

Delta Industrial Automation introduces the CP2000 Series AC motor drive for energy-saving HVAC systems and for pump and fan applications. The CP2000 Series is equipped with special HVAC parameters and PID control functions for efficient operation, as well as multi-segment V/F control curve and soft start functions to assist frequent torque change and constant output applications with energy-saving performance.





CP2000

Water Circulation Pump Control

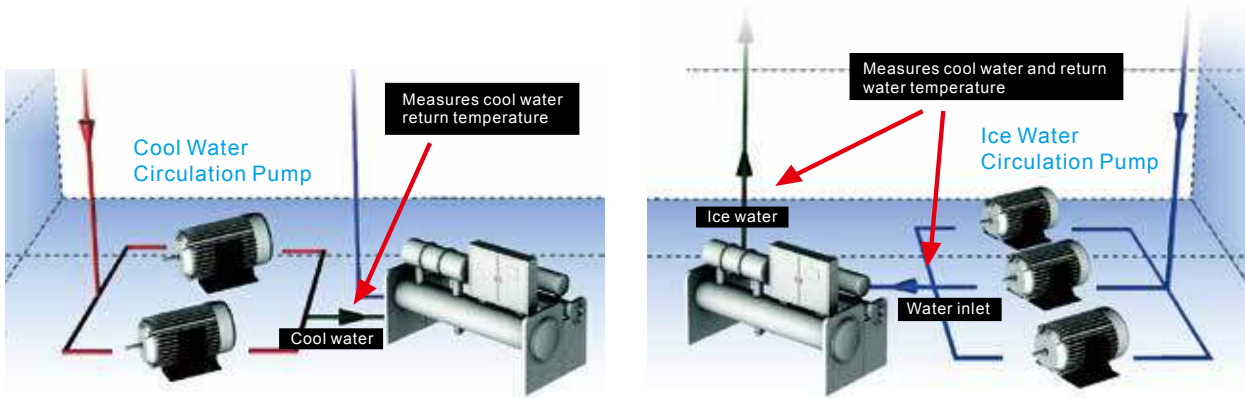

Figure1: Multi-Pump Control

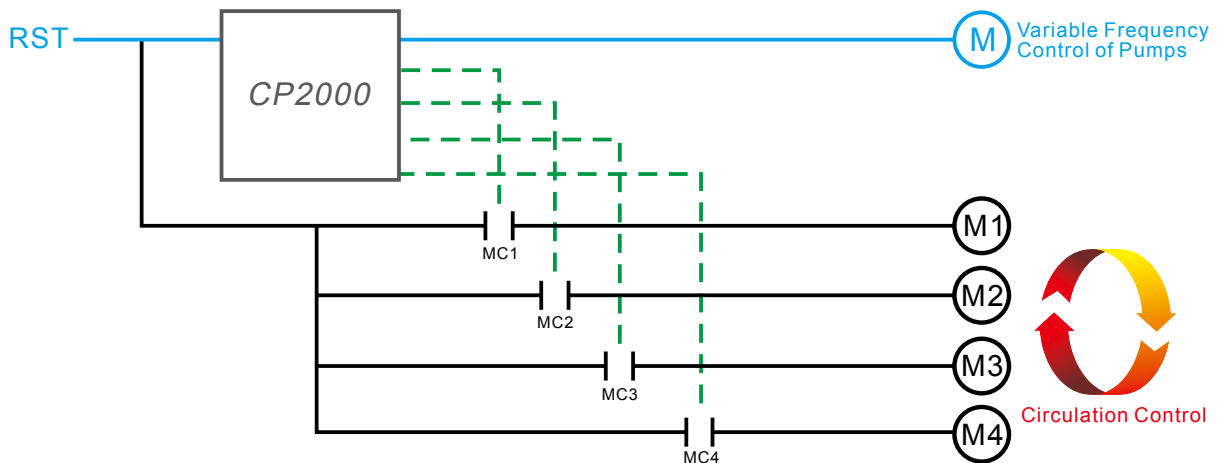

Figure 2: Fixed Amount and Circulation Control

Features

- ▶ LCD keypad - An easy-to-use text panel with TP Editor software allows users to customize the main page screen
- ▶ Quick setting functions to support self-defined parameter groups and parameter duplication for fast and easy installation
- ▶ Modular design for flexible extension and easy maintenance
- ▶ High-speed communications include BACnet and Modbus. Optional communication cards are available upon purchase: PROFIBUS DP, PROFINET, DeviceNet, Modbus TCP, EtherNet/IP, CANopen and BACnet IP
- ▶ Extended life cycle
- ▶ Enhanced conformal coating on PCBs for superior durability in critical environments
- ▶ Fire mode and bypass functions: continuous pressure to extract smoke when emergencies occur
- ▶ Various modes for fans/pump applications including PID control, sleep/wake up functions, flying start and skip frequency
- ▶ Multi-pumps synchronous control of up to 8 motors at one time and provides fixed amount and fixed time circulation control
- ▶ Built-in 10K steps PLC programming capacity and Real Time Clock (RTC)

Advanced Drive Technology

High Performance Variable Frequency Drive Technology

1. Sensorless Vector Control (SVC)
2. Dual rating design (Light duty & Normal duty)
3. Excellent variable torque control of asynchronous motors

Versatile Drive Control

1. Built-in PLC function
2. Built-in brake unit*
3. Networking drive system
4. Auto energy saving



Modular Design

1. Hot pluggable LCD keypad
2. I/O extension card
3. Various communication cards
4. Removable fans

Environmental Adaptability

1. 50°C operation temperature
2. Built-in DC choke*
3. Coated circuit boards
4. Built-in EMC filter*
5. International safety standard CE/UL/cUL

*Note: Please refer to the Product Specifications for more details.

Standard Models

Power range: 230V 0.75~90kW, 460V 0.75~630kW

230 V (kW)	0.75	1.5	2.2	3.7	5.5	7.5	11	15	18.5	22	30	37	45	55	75	90
230 V (HP)	1	2	3	5	7.5	10	15	20	25	30	40	50	60	75	100	125
Frame Size	A				B			C			D		E			

460 V (kW)	0.75	1.5	2.2	3.7	4.0	5.5	7.5	11	15	18.5	22	30	37
460 V (HP)	1	2	3	5	5	7.5	10	15	20	25	30	40	50
Frame Size	A						B			C			

460 V (kW)	45	55	75	90	110	132	160	185	200	220	250	280	315	355	400	500	560	630
460 V (HP)	60	75	100	125	150	175	215	250	270	300	340	375	425	475	530	675	750	850
Frame Size	D0		D		E		F		G				H					

Power range: 575V 1.5~15kW, 690V 18.5~630kW

575 V (kW)	1.5	2.2	3.7	5.5	7.5	11	15
575 V (HP)	2	3	5	7.5	10	15	20
Frame Size	A			B			

690 V (kW)	18.5	22	30	37	45	55	75	90	110	132	160	200	250	315
690 V (HP)	25	30	40	50	60	75	100	125	150	175	215	270	335	425
Frame Size	C			D		E				F		G		

690 V (kW)	400	450	560	630
690 V (HP)	530	600	750	850
Frame Size	H			

High-Speed Network

- ▶ Advanced network functions

- Built-in RS-485 (Modbus)
- Built-in BACnet MS/TP 

- ▶ Various communication card options

PROFINET, PROFIBUS DP, **EtherNet/IP**, BACnet IP, DeviceNet, Modbus TCP, CANopen (DS402)

Building Automation Applications

- ▶ 4-point adjustable V/F control - Real-time adjustment of output voltage under variable torque load environments, especially for pump and fan applications.
- ▶ Flying start and auto restart after momentary power loss functions, suitable for fan application.
- ▶ Skip frequency function avoids mechanical resonance and protects the equipment.
- ▶ Low-current protection function prevents free load operation.
- ▶ Built-in BACnet communication protocol saves wiring for building automation applications.

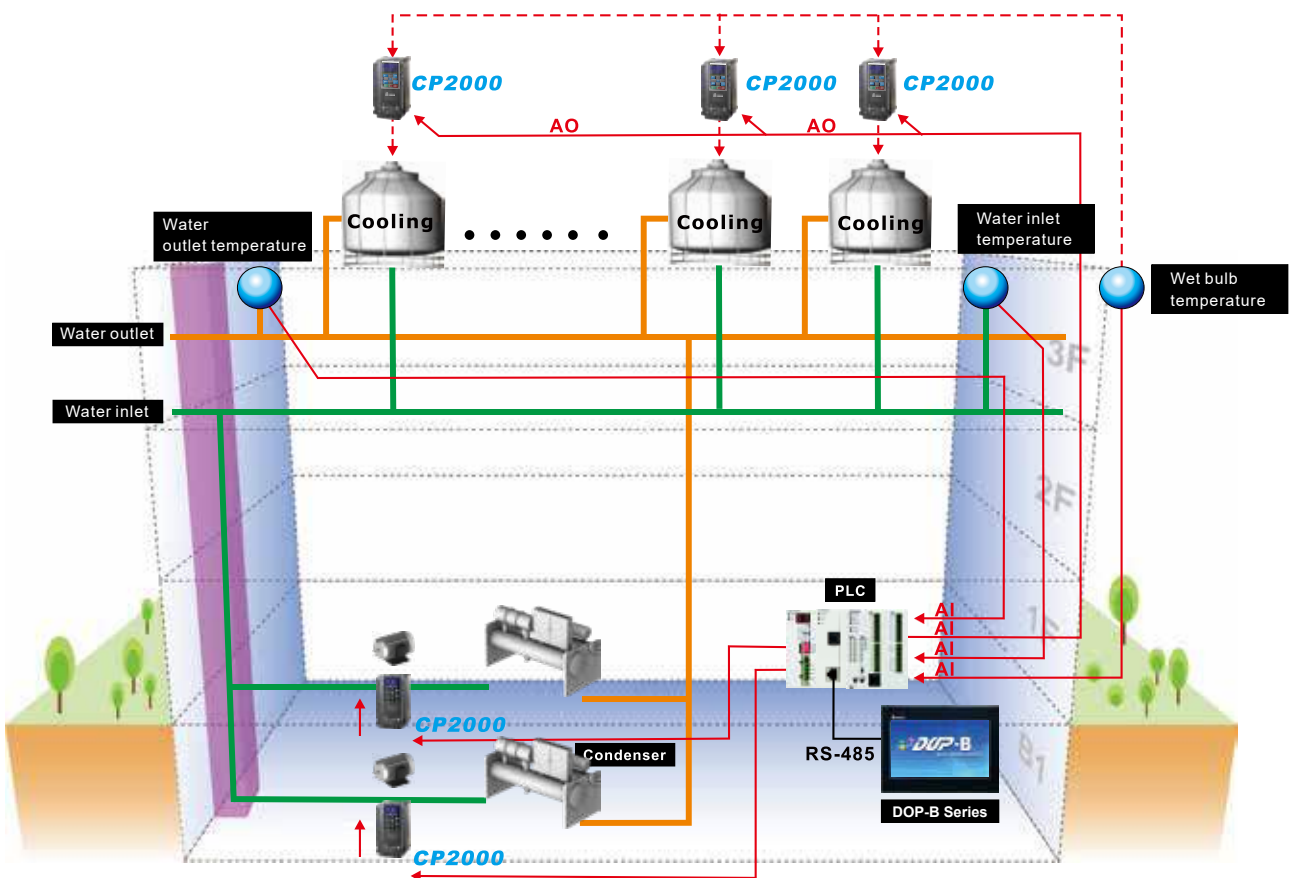

Improves Motor Performance

- ▶ Sensorless Vector Control (SVC) and auto-tuning functions improve motor performance for variable torque load applications.
- ▶ Deceleration Energy Backup (DEB) function decelerates motor to a stop when sudden power failure occurs to protect the equipment from damage.
- ▶ Auto adjusting acceleration/deceleration speed, reduces mechanical vibration when activating and stopping the equipment and provides smooth operation.
- ▶ Energy saving control functions include PID control, sleep/wakeup mode and auto-energy saving mode.

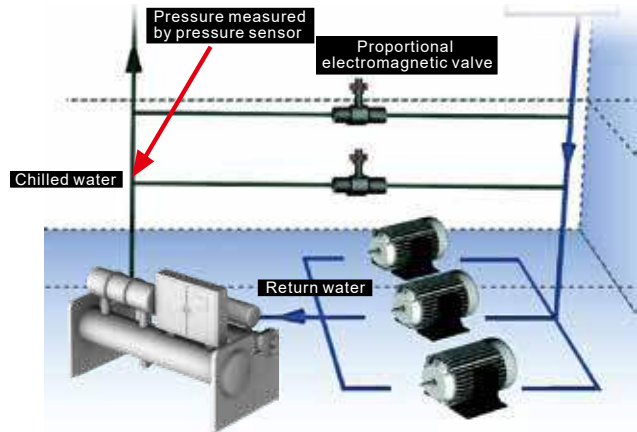
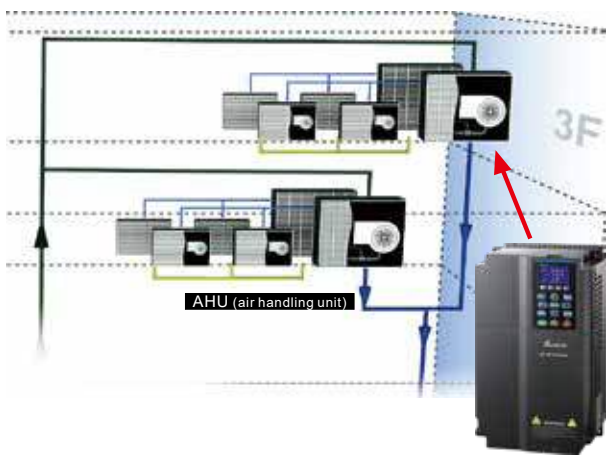

Built-in PLC Function

- ▶ Built-in 10K steps PLC function supports independent and distributed control when connecting to a network system for high operation flexibility.
- ▶ Real Time Clock (RTC) function facilitates the PLC program writing process for ON/OFF chronology, daylight saving operation and many other settings.

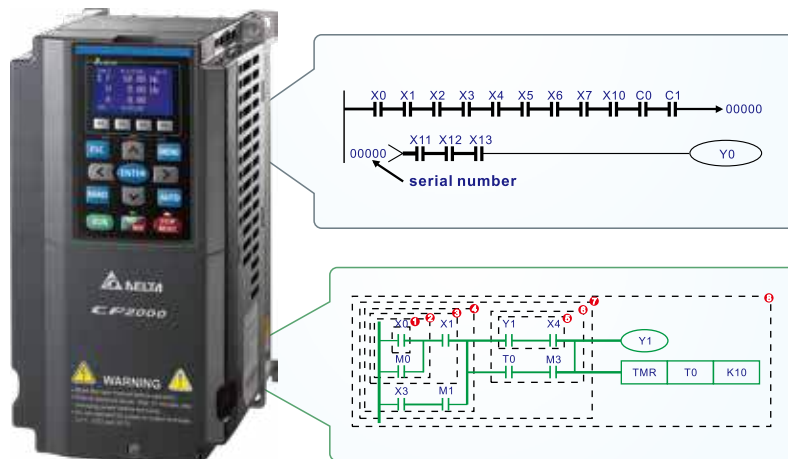

Standards

<ul style="list-style-type: none"> ■ CE Low Voltage: EN61800-5-1 	EMC: EN61000-3-12, EN61800-3, IEC61000-6-2, IEC61000-6-4, IEC61000-4-2, IEC61000-4-3, IEC61000-4-4, IEC61000-4-5, IEC61000-4-6, IEC61000-4-8
■ UL, cUL	
■ RCM	
■ ROHS	

Modular Design

Powerful motor drive control functions. The modular design satisfies various system applications with higher flexibility and is easy to maintain. Accessories include input/output extension cards, communication cards, hot pluggable LCD keypad, removable terminal blocks and removable fans.

- KPC-CC01 keypad
- Standard RJ45 cable for remote operation.
- Easy to install and remove with one press.



- The product nameplate shows the input/output voltage, input /output current, frequency range, and more.



- Remove the safety screws and press on both side tabs to remove the cover.

- Modular fan design, easy to replace and clean, extending product life.

- RFI Jumper



High Adaptability to Environment

- ▶ Built-in DC choke to suppress harmonics*
- ▶ Built-in EMC and RFI filter for noise suppression*
- ▶ Enhanced conformal coating on PCBs for superior durability in critical environments.
- ▶ The electronic components of the drive are isolated from the cooling system to reduce heat interference. Dissipated heat can be discharged by flange-mounting installation, and forced fan cooling can import cold air into the heat sink. The heat dissipation performance is optimized by these two cooling methods.



Note: Please refer to the Product Specifications for more detail

Environment for Operation, Storage and Transportation

DO NOT expose the AC motor drive to harsh environments, such as dust, direct sunlight, corrosive/flammable gasses, humidity, liquid or vibrations. The salts in the air must be less than 0.01 mg/cm² per year.

Environment	Installation Location	IEC60364-1/IEC60664-1 Pollution degree 2, indoor use only	
	Surrounding Temperature	Storage/Transportation (°C)	-25 ~ 70
		Non-condensation, non-frozen	
	Rated Humidity	Operation	Max. 95%
		Storage/Transportation	Max. 95%
		No condense water	
	Air Pressure	Operation/Storage (kPa)	86 ~ 106
		Transportation (kPa)	70 ~ 106
	Pollution Level	IEC60721-3-3	
		Operation	Class 3C3; Class 3S2
Storage		Class 1C2; Class 1S2	
Transportation		Class 2C2; Class 2S2	
If the AC motor drive is to be used under harsh conditions with high level of contamination (e.g. dew, water, dust), make sure it is installed in an environment qualified for IP54 such as in a cabinet.			
Altitude	Operation	If the AC motor drive is installed at an altitude of 0~1,000m, follow normal operation restrictions. If it is installed at altitude 1,000~2,000m, decrease 1% of rated current or lower 0.5°C of temperature for every 100m increase in altitude. Maximum altitude for Corner Grounded TN system is 2,000m. For application over 2,000m, please contact Delta for more details.	
	Package Drop		
Storage/Transportation		ISTA procedure 1A (according to weight) IEC60068-2-31	
Vibration		1.0mm, peak to peak value range from 2Hz to 13.2Hz; 0.7G~1.0G range from 13.2Hz to 55Hz; 1.0G range from 55Hz to 512Hz. Comply with IEC 60068-2-6.	
Impact		IEC/EN 60068-2-27	
Operation Position		Max. allowed offset angle ±10° (under normal installation position)	

Specifications for Operation Temperature and Protection Level

Model	Frame	Top Cover	Conduit Box	Protection Level	Operation Temperature
VFDxxxCP23x-21 VFDxxxCP43x-21 VFDxxxCP4Ex-21 VFDxxxCP53x-21 VFDxxxCP63x-xx	Frame A~C 230V: 0.75~30kW 460V: 0.75~37kW 575V: 1.5~15kW 690V: 18.5~37kW	Remove top cover	Standard conduit plate	IP20/UL Open Type	30V & 460V: -10°C~50°C*1 575V & 690V: -10°C~50°C
		Standard with top cover		IP20/UL Type1/NEMA1	-10°C~40°C
	Frame D~H 230V: ≥ 37kW 460V: ≥ 45kW 690V: ≥ 45kW	N/A	Conduit box	IP20/UL Type1/NEMA1	-10°C~40°C
VFDxxxCP23x-00 VFDxxxCP43x-00 VFDxxxCP63x-00	Frame D~H 230V: ≥ 37kW 460V: ≥ 45kW 690V: ≥ 45kW	N/A	No conduit box	IP00 IP20/UL Open Type	230V & 460V: -10°C~50°C*1 690V: -10°C~50°C

Protection degree for the circled area is IP00; other areas are IP20

*1 When the carrier wave for light duty is 2kHz, the maximum operation temperature can reach up to 50°C

Specifications

230 V																			
Frame Size		A					B			C			D		E				
Model VFD-□□□□CP23□-□□		007	015	022	037	055	075	110	150	185	220	300	370	450	550	750	900		
Output Rating	LIGHT DUTY	Rated Output Capacity (kVA)	2.0	3.0	4.0	6.0	8.4	12	18	24	30	36	42	58	72	86	110	128	
		Rated Output Current (A)	5	7.5	10	15	21	31	46	61	75	90	105	146	180	215	276	322	
		Applicable Motor Output (kW)	0.75	1.5	2.2	3.7	5.5	7.5	11	15	18.5	22	30	37	45	55	75	90	
		Applicable Motor Output (HP)	1	2	3	5	7.5	10	15	20	25	30	40	50	60	75	100	125	
		Overload Tolerance	120% of rated current for 1 minute during every 5 minutes																
	NORMAL DUTY	Max. Output Frequency (Hz)	599.00														400.00		
		Carrier Frequency (kHz)	2~15 (default setting 8)						2~10 (default setting 6)						2~9 (default setting 4)				
		Rated Output Capacity (kVA)	1.2	2.0	3.2	4.4	6.8	10	13	20	26	30	36	48	58	72	86	102	
		Rated Output Current (A)	3	5	8	11	17	25	33	49	65	75	90	120	146	180	215	255	
		Applicable Motor Output (kW)	0.4	0.75	1.5	2.2	3.7	5.5	7.5	11	15	19	22	30	37	45	55	75	
Input Rating	LIGHT DUTY	Applicable Motor Output (HP)	0.5	1	2	3	5	7.5	10	15	20	25	30	40	50	60	75	100	
		Overload Tolerance	120% of rated current for 1 minute during every 5 minutes; 160% of rated current for 3 seconds during every 25 seconds																
		Max. Output Frequency (Hz)	599.00														400.00		
		Carrier Frequency (kHz)	2~15 (default setting 8)						2~10 (default setting 6)						2~9 (default setting 4)				
		Rated Output Capacity (kVA)	1.2	2.0	3.2	4.4	6.8	10	13	20	26	30	36	48	58	72	86	102	
	NORMAL DUTY	Rated Output Current (A)	3	5	8	11	17	25	33	49	65	75	90	120	146	180	215	255	
		Applicable Motor Output (kW)	0.4	0.75	1.5	2.2	3.7	5.5	7.5	11	15	19	22	30	37	45	55	75	
		Applicable Motor Output (HP)	0.5	1	2	3	5	7.5	10	15	20	25	30	40	50	60	75	100	
		Overload Tolerance	120% of rated current for 1 minute during every 5 minutes; 160% of rated current for 3 seconds during every 25 seconds																
		Max. Output Frequency (Hz)	599.00														400.00		
Input Rating	LIGHT DUTY	Carrier Frequency (kHz)	2~15 (default setting 8)						2~10 (default setting 6)						2~9 (default setting 4)				
		Input Current (A) Light Duty	6.4	9.6	15	22	25	35	50	65	83	100	116	146	180	215	276	322	
		Input Current (A) Normal Duty	3.9	6.4	12	16	20	28	36	52	72	83	99	124	143	171	206	245	
		Rated Voltage/Frequency	3-phase, 200~240V _{AC} (-15%~+10%), 50/60 Hz																
		Operating Voltage Range	170~264V _{AC}																
	NORMAL DUTY	Frequency Tolerance	47~63 Hz																
		Efficiency (%)	97.8														98.2		
		Power Factor	>0.98																
		Weight (Kg)	2.6 ± 0.3					5.4 ± 1			9.8 ± 1.5			38.5 ± 1.5		64.8 ± 1.5			
		Cooling Method	Natural Cooling		Fan Cooling														
Braking Chopper	Frame A, B, C, Built-in												Frame D and above: Optional						
DC Choke	Frame A, B, C, Optional												Frame D and above: Built-in 3%						
EMC Filter	Optional																		

460 V																			
Frame Size		A					B			C			D0						
Models VFD-□□□□CP43□-□□ VFD-□□□□CP4E□-□□		007	015	022	037	040	055	075	110	150	185	220	300	370	450	550			
Output Rating	LIGHT DUTY	Rated Output Capacity (kVA)	2.4	3.3	4.4	6.8	8.4	10.4	14.3	19	25	30	36	48	58	73	88		
		Rated Output Current (A)	3	4.2*	5.5*	8.5*	10.5	13*	18*	24*	32*	38*	45	60*	73*	91	110		
		Applicable Motor Output (kW)	0.75	1.5	2.2	3.7	4.0	5.5	7.5	11	15	18.5	22	30	37	45	55		
		Applicable Motor Output (HP)	1	2	3	5	5	7.5	10	15	20	25	30	40	50	60	75		
		Overload Tolerance	120% of rated current for 1 minute during every 5 minutes																
	NORMAL DUTY	Max. Output Frequency (Hz)	599.00																
		Carrier Frequency (kHz)	2~15 (default setting 8)						2~10 (default setting 6)										
		Rated Output Capacity (kVA)	2.2	2.4	3.2	4.8	7.2	8.4	10.4	14.3	19	25	30	36	48	58	73	88	
		Rated Output Current (A)	1.7	3.0	4.0	6.0	9.0	10.5	12	18	24	32	38	45	60	73	91	110	
		Applicable Motor Output (kW)	0.4	0.75	1.5	2.2	3.7	4.0	5.5	7.5	11	15	18.5	22	30	37	45	55	
Input Rating	LIGHT DUTY	Applicable Motor Output (HP)	0.5	1	2	3	5	5	7.5	10	15	20	25	30	40	53	60		
		Overload Tolerance	120% of rated current for 1 minute during every 5 minutes; 160% of rated current for 3 seconds during every 25 seconds																
		Max. Output Frequency (Hz)	599.00																
		Carrier Frequency (kHz)	2~15 (default setting 8)						2~10 (default setting 6)										
		Rated Output Capacity (kVA)	2.2	2.4	3.2	4.8	7.2	8.4	10.4	14.3	19	25	30	36	48	58	73	88	
	NORMAL DUTY	Rated Output Current (A)	1.7	3.0	4.0	6.0	9.0	10.5	12	18	24	32	38	45	60	73	91	110	
		Applicable Motor Output (kW)	0.4	0.75	1.5	2.2	3.7	4.0	5.5	7.5	11	15	18.5	22	30	37	45	55	
		Applicable Motor Output (HP)	0.5	1	2	3	5	5	7.5	10	15	20	25	30	40	53	60	75	
		Overload Tolerance	120% of rated current for 1 minute during every 5 minutes; 160% of rated current for 3 seconds during every 25 seconds																
		Max. Output Frequency (Hz)	599.00																
Input Rating	LIGHT DUTY	Carrier Frequency (kHz)	2~15 (default setting 8)						2~10 (default setting 6)										
		Input Current (A) Light Duty	4.3	6.0	8.1	12.4	16	20	22	26	35	42	50	66	80	91	110		
		Input Current (A) Normal Duty	3.5	4.3	5.9	8.7	14	15.5	17	20	26	35	40	47	63	74	101		
		Rated Voltage/Frequency	3-phase, 380~480V _{AC} (-15%~+10%), 50/60 Hz																
		Operating Voltage Range	323~528V _{AC}																
	NORMAL DUTY	Frequency Tolerance	47~63 Hz																
		Efficiency (%)	97.8																
		Power Factor	>0.98																
		Weight (Kg)	2.6 ± 0.3					5.4 ± 1			9.8 ± 1.5			27 ± 1					
		Cooling Method	Natural cooling		Fan cooling														
Braking Chopper	Frame A, B, C, Built-in; Frame D and above, Optional																		
DC Choke	Frame A, B, C, Optional; Frame D and above, Built-in 3%																		
EMC Filter	Frame A, B, C of VFD____CP4EA_-_-; Built-in Frame A, B, C of VFD____CP43A_-_-; no built-in Frame D above, Optional																		

* It means the rated output current is for the models of version B. (e.g. VFD015CP43B-21)

460 V

Frame Size		D		E		F		G			H								
Model VFD-□□□□CP43□-□□		750	900	1100	1320	1600	1850	2000	2200	2500	2800	3150	3550	4000	5000	5600	6300		
Output Rating	LIGHT DUTY	Rated Output Capacity (kVA)	120	143	175	207	247	295	315	367	383	422	491	544	613	773	872	966	
		Rated Output Current (A)	150*	180	220	260*	310	370*	395	460	481	530	616	683	770	930	1094	1212	
		Applicable Motor Output (kW)	75	90	110	132	160	185	200	220	250	280	315	355	400	500	560	630	
		Applicable Motor Output (HP)	100	125	150	175	215	250	270	300	340	375	425	475	530	675	750	850	
		Overload Tolerance	120% of rated current for 1 minute during every 5 minutes																
		Max. Output Frequency (Hz)	599.00	400.00															
		Carrier Frequency (kHz)	2~10 (default setting 6)	2~9 (default setting 4)															
	NORMAL DUTY	Rated Output Capacity (kVA)	88	120	143	175	207	247	270	295	315	367	438	491	544	720	741	872	
		Rated Output Current (A)	110	150	180	220	260	310	310	370	395	460	550	616	683	866	930	1094	
		Applicable Motor Output (kW)	55	75	90	110	132	160	160	185	200	220	280	315	355	450	500	560	
		Applicable Motor Output (HP)	75	100	125	150	175	215	215	250	270	300	375	425	475	600	675	750	
		Overload Tolerance	120% of rated current for 1 minute during every 5 minutes; 160% of rated current for 3 seconds during every 25 seconds																
		Max. Output Frequency (Hz)	599.00	400.00															
		Carrier Frequency (kHz)	2~10 (default setting 6)	2~9 (default setting 4)															
Input Rating	Input Current (A) Light Duty	150	180	220	260	310	370	395	460	481	530	616	683	770	930	1094	1212		
	Input Current (A) Normal Duty	114	157	167	207	240	300	300	380	390	400	494	555	625	866	930	1094		
	Rated Voltage/Frequency	3-phase, 380~480 V _{AC} (-15%~+10%), 50/60 Hz																	
	Operating Voltage Range	323~528 V _{AC}																	
Frequency Tolerance	47~63 Hz																		
Efficiency (%)	97.8	98.2																	
Power Factor	>0.98																		
Weight (Kg)	38.5 ± 1.5	64.8 ± 1.5	86.5 ± 1.5	134 ± 4			228												
Cooling Method	Fan cooling																		
Braking Chopper	Frame D above, Optional																		
DC Choke	Frame D above, Built-in, 3%																		
EMC Filter	Frame D above, Optional																		

* It means the rated output current is for the models of Version B. (e.g. VFD015CP43B-21)

575 V

Frame Size		A				B				
Model VFD-□□□CP53A-21		015	022	037	055	075	110	150		
Output *	LIGHT DUTY	Rated Output Capacity (kVA)	3	4.3	6.7	9.9	12.1	18.6	24.1	
		Rated Output Current (A)	3	4.3	6.7	9.9	12.1	18.7	24.2	
		Applicable Motor Output (kW)	1.5	2.2	3.7	5.5	7.5	11	15	
		Applicable Motor Output (HP)	2	3	5	7.5	10	15	20	
	NORMAL DUTY	Rated Output Capacity (kVA)	2.5	3.6	5.5	8.2	10	15.4	19.9	
		Rated Output Current (A)	2.5	3.6	5.5	8.2	10	15.4	20	
		Applicable Motor Output (kW)	0.75	1.5	2.2	3.7	5.5	7.5	11	
		Applicable Motor Output (HP)	1	2	3	5	7.5	10	15	
Carrier Frequency (kHz)	2~9 (default setting 4)									
Input	Input Current (A) Light Duty	3.8	5.4	10.4	14.9	16.9	21.3	26.3		
	Input Current (A) Normal Duty	3.1	4.5	7.2	12.3	15	18	22.8		
	Rated Voltage/Frequency	3-Phase, 525~600 V _{AC} (-15%~+10%), 50/60 Hz								
	Operating Voltage Range	446~660 V _{AC}								
Frequency Tolerance	47~63 Hz									
Efficiency (%)	97				98					
Power Factor	>0.98									
AC Drive Weight (Kg)	3±0.3				4.8±1					
Cooling Method	Natural cooling				Fan cooling					
Braking Chopper	Built-in									
DC Choke	Optional									

690V												
Frame Size		C				D		E				
Model VFD-□□□CP63A-□□		185	220	300	370	450	550	750	900	1100	1320	
Output *	LIGHT DUTY	Rated Output Capacity (kVA)	29	36	43	54	65	80	103	124	149	179
		Applicable Motor Output (690V, kW)	18.5	22	30	37	45	55	75	90	110	132
		Applicable Motor Output (690V, HP)	25	30	40	50	60	75	100	125	150	175
		Applicable Motor Output (575V, HP)	20	25	30	40	50	60	75	100	125	150
		Rated Output Current (A)	24	30	36	45	54	67	86	104	125	150
		Overload Tolerance	120% of rated current for 1 minute during every 5 minutes									
		Max. Output Frequency (Hz)	599.00									
	NORMAL DUTY	Rated Output Capacity (kVA)	24	29	36	43	54	65	80	103	124	149
		Applicable Motor Output (690V, kW)	15	18.5	22	30	37	45	55	75	90	110
		Applicable Motor Output (690V, HP)	20	25	30	40	50	60	75	100	125	150
		Applicable Motor Output (575V, HP)	15	20	25	30	40	50	60	75	100	125
		Rated Output Current (A)	20	24	30	36	45	54	67	86	104	125
		Overload Tolerance	120% of rated current for 1 minute during every 5 minutes; 160% of rated current for 3 seconds during every 25 seconds									
		Max. Output Frequency (Hz)	599.00									
Carrier Frequency (kHz)	2~9 (default setting 4)											
Input	Input Current (A) Light Duty	29	36	43	54	65	81	84	102	122	147	
	Input Current (A) Normal Duty	24	29	36	43	54	65	66	84	102	122	
	Rated Voltage/Frequency	3-Phase, 525~690 V _{AC} (-15%~+10%), 50/60 Hz										
	Operating Voltage Range	446~759 V _{AC}										
	Frequency Tolerance	47~63 Hz										
Efficiency (%)	97											
Power Factor	>0.98											
AC Drive Weight (Kg)	10±1.5				39±1.5			61±1.5				
Cooling Method	Fan cooling											
Braking Chopper	Frame C (built-in)					Frame D and above (optional)						
DC Choke	Frame C (optional)					Frame D and above (built-in)						

690V												
Frame Size		F			G		H					
Model VFD-□□□CP63A-□□		1600	2000	2500	3150	4000	4500	5600	6300			
Output *	LIGHT DUTY	Rated Output Capacity (kVA)	215	263	347	418	494.5	534.7	678.5	776		
		Applicable Motor Output (690V, kW)	160	200	250	315	400	450	560	630		
		Applicable Motor Output (690V, HP)	215	270	335	425	530	600	750	850		
		Applicable Motor Output (575V, HP)	150	200	250	350	400	450	500	750		
		Rated Output Current (A)	180	220	290	350	430	465	590	675		
		Overload Tolerance	120% of rated current for 1 minute during every 5 minutes									
		Max. Output Frequency (Hz)	599.00									
	NORMAL DUTY	Rated Output Capacity (kVA)	179	215	239	347	402.5	442.7	534.7	776		
		Applicable Motor Output (690V, kW)	132	160	200	250	315	355	450	630		
		Applicable Motor Output (690V, HP)	175	215	270	335	425	475	600	850		
		Applicable Motor Output (575V, HP)	150	150	200	250	350	400	450	750		
		Rated Output Current (A)	150	180	220	290	350	385	465	675		
		Overload Tolerance	120% of rated current for 1 minute during every 5 minutes; 160% of rated current for 3 seconds during every 25 seconds									
		Max. Output Frequency (Hz)	599.00									
Carrier Frequency (kHz)	2~9 (default setting 4)									2~9 (default setting 3)		
Input	Input Current (A) Light Duty	178	217	292	353	454	469	595	681			
	Input Current (A) Normal Duty	148	178	222	292	353	388	504	681			
	Rated Voltage/Frequency	3-Phase, 525~690 V _{AC} (-15%~+10%), 50/60 Hz										
	Operating Voltage Range	446~759 V _{AC}										
	Frequency Tolerance	47~63 Hz										
Efficiency (%)	97					98						
Power Factor	>0.98											
AC Drive Weight (Kg)	88±1.5			135±4			243±5					
Cooling Method	Fan cooling											
Braking Chopper	Frame D and above (optional)											
DC Choke	Frame D and above (built-in)											

Note : 1. When a load is a surge load, use a higher level model.
2. For Frame A, B and C, Model VFDXXXCPXXX-21, the enclosure type is IP20/ UL OPEN TYPE.
3. For Frame D and above, if the last two characters of the model are 00, then the enclosure type is IP00/ IP20/ UL OPEN TYPE; if the last two characters of the model are 21, the enclosure type is IP20/NEMA1/ UL TYPE1.

General Specifications

Control Characteristics	Control Method	Pulse Width Modulated (PWM)			
	Control Mode	1: V/F (V/F control), 2: SVC (Sensorless Vector Control), 3: PM (Permanent Magnet Motor)			
	Starting Torque	Reach up to 150% or above at 0.5Hz			
	V/F Curve	4 point adjustable V/F curve and square curve			
	Speed Response Ability	5Hz			
	Torque Limit	Light Duty: Max. 130% torque current; Normal Duty: Max. 160% torque current			
	Torque Accuracy	±5%			
	Max. Output Frequency (Hz)	230 V model: 599.00 (55kW and above: 400.00) 460 V model: 599.00 (90kW and above: 400.00) 575V/690 V model: 599.00			
	Frequency Output Accuracy	Digital command: ±0.01%, -10 °C~+40 °C, Analog command: ±0.1%, 25 ±10 °C			
	Output Frequency Resolution	Digital command: 0.01 Hz; Analog command: Max. output frequency×0.03/60Hz (±11 bit)			
	Overload Tolerance	Light duty: 120% of rated current for 1 minute during every 5 minutes Normal duty: 120% of rated current for 1 minute during every 5 minutes; 160% of rated current for 3 seconds during every 25 seconds			
	Frequency Setting Signal	0 ~ +10V, 4 ~ 20 mA, 0 ~ 20 mA			
Accel./decel. Time	0.00 ~ 600.00/0.0 ~ 6000.0 seconds				
Main Control Function	Fault restart	Torque limit	High-Slip braking	Dwell	3-wire sequence
	Speed search	Parameter copy	JOG frequency	Slip compensation	Torque compensation
	S-curve accel/decel	Energy saving control	Accel/Decel. Time switch	Frequency upper/lower limit settings	Momentary power loss ride thru
	PID control (with sleep function)	Auto-Tuning (rotational, stationary)	DC injection braking at start/stop	BACnet Communication	17-step speed (max.)
	Over-torque detection	Modbus communication (RS-485 RJ45, Max. 5.2Kbps)			
Fan Control	230 V model: Model with spec higher than VFD185CP23 (included) are PWM control; Model with spec lower than VFD150CP23 (not included) are on/off switch control. 460 V model: Model with spec higher than VFD220CP43/4E (included) are PWM control; Model with spec lower than VFD185CP43/4E (not included) are on/off switch control. 575V/690 V model: PWM control				
Protection Characteristics	Motor Protection	Electronic thermal relay protection			
	Over-Current Protection	230V/460V model: Light duty: Over-current protection for 185% rated current, Normal duty: Over-current protection for 240% rated current, Current clamp (Light duty: 130~135%) ; (Normal duty: 170~175%)			
		575V/690V model: Over-current protection for 225% rated current Current clamp (Light duty: around 128~141%) ; (Normal duty: around 170~175%)			
	Over-Voltage Protection	230V model: drive will stop when DC bus voltage exceeds 410V 460V model: drive will stop when DC bus voltage exceeds 820V 575V model: drive will stop when DC bus voltage exceeds 1016V 690V model: drive will stop when DC bus voltage exceeds 1189V			
	Over-Temperature Protection	Built-in temperature sensor			
	Stall Prevention	Stall prevention during acceleration, deceleration and running independently			
	Restart After Instantaneous Power Failure	Parameter setting up to 20 seconds			
	Grounding Leakage Current Protection	Leakage current is higher than 50% of rated current of the AC motor drive			
Short-circuit Current Rating (SCCR)	Per UL508C, the drive is suitable for use on a circuit capable of delivering not more than 100kA symmetrical amperes (rms) when protected by fuses given in the fuse table				
International Certifications*	 SEMI F47, GB/T12668.3				

Note : 1. EAC Certification is for 230 V and 460 V models only
2. No UL certification for models above 500 kW

Wiring

Wiring Diagram for Frame A ~ C

*Input: 3-phase power

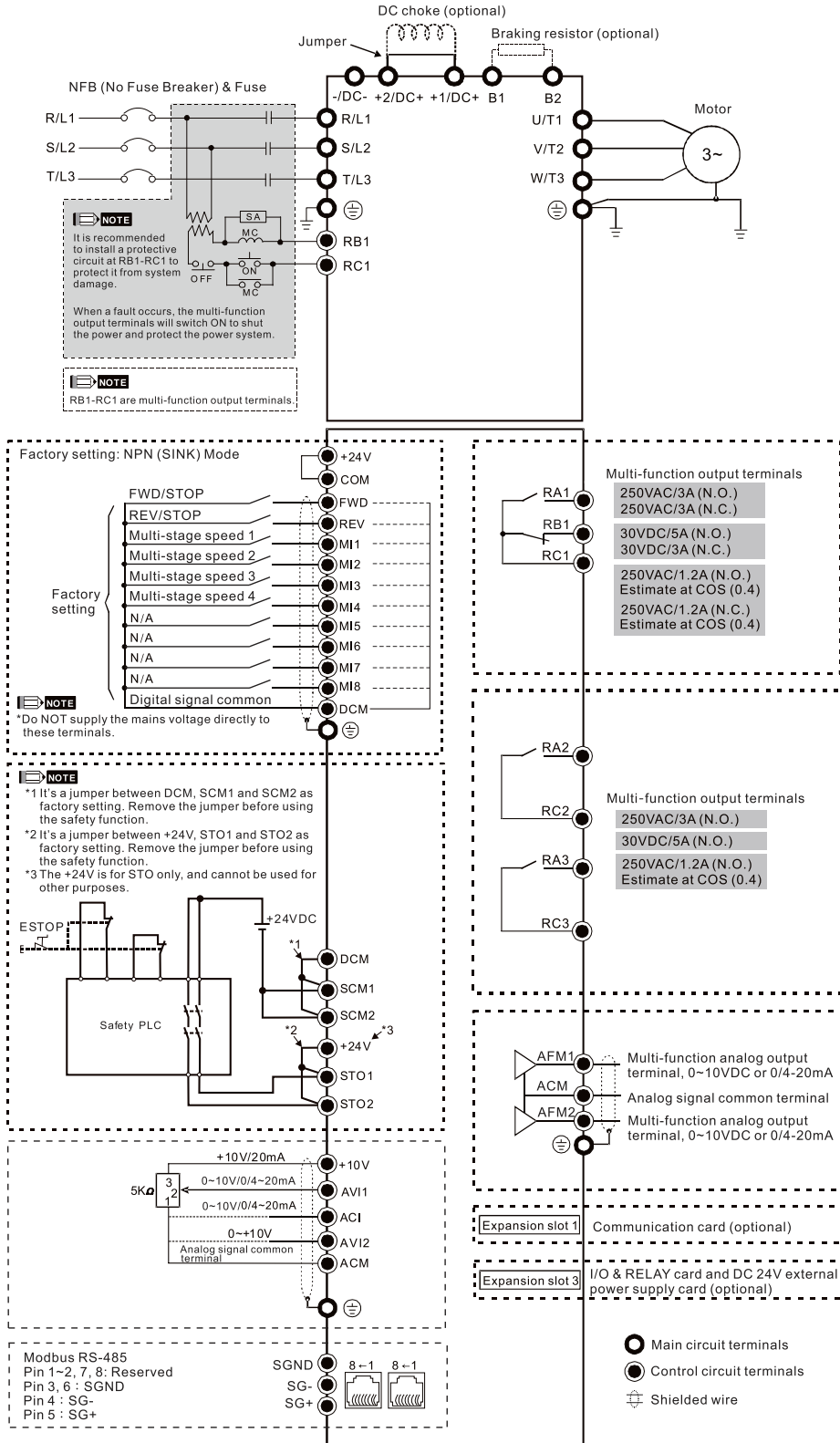

Wiring Diagram for Frame D ~ F

*Input: 3-phase power

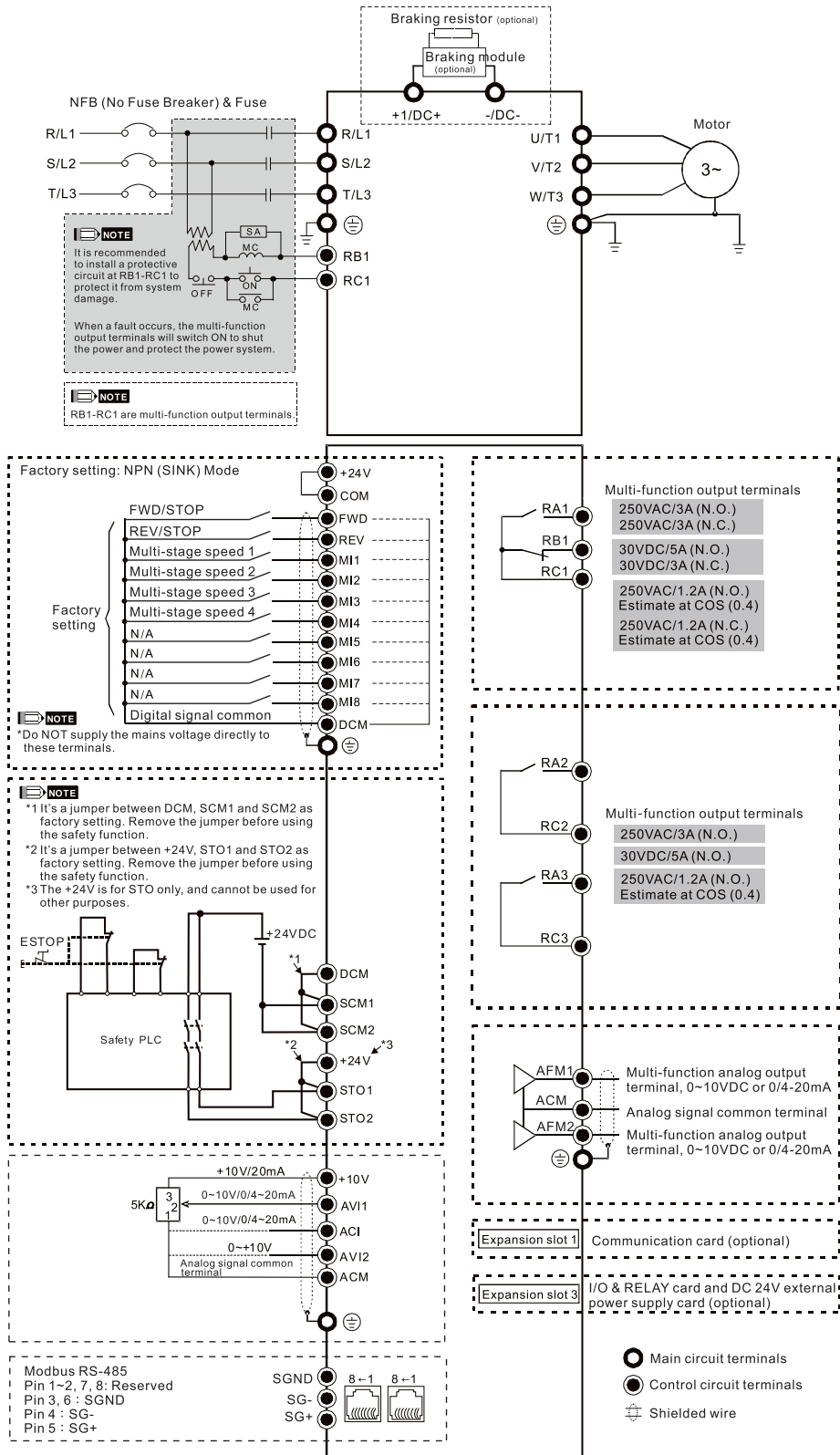

Wiring Diagram for Frame G ~ H

*Input: 3-phase power

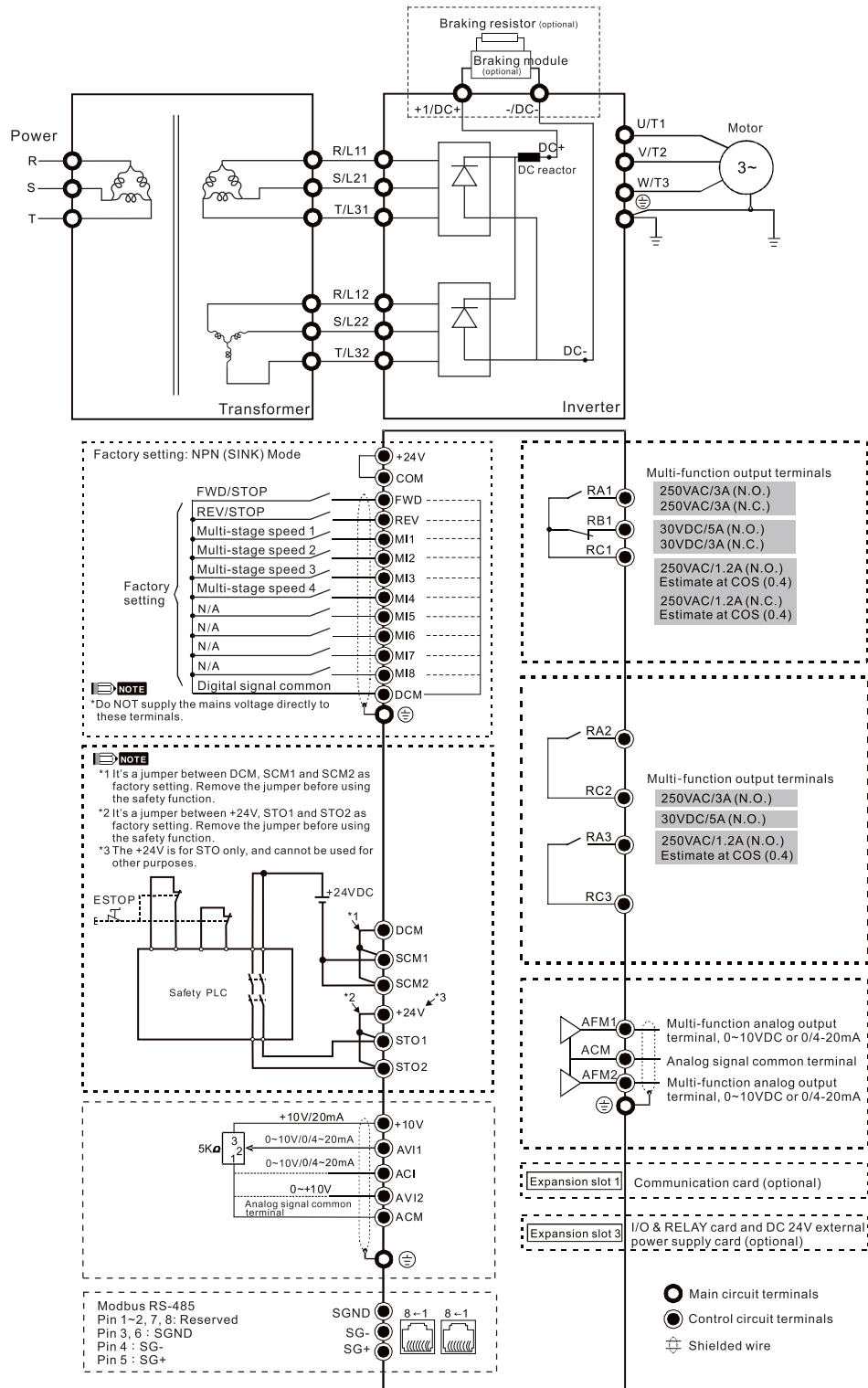

• When wiring for 12 Pulse Input, please strictly follow above wiring diagram.

Dimensions

Digital Keypad Unit: mm [inch]

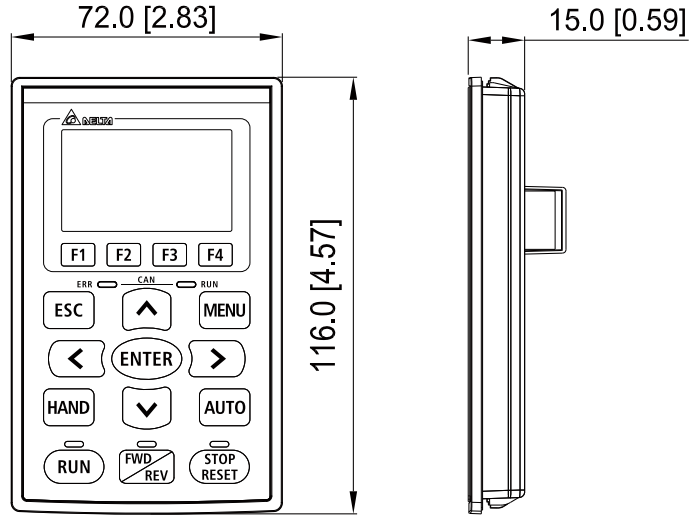

KPC-CC01

Standard LCD keypad

Frame A

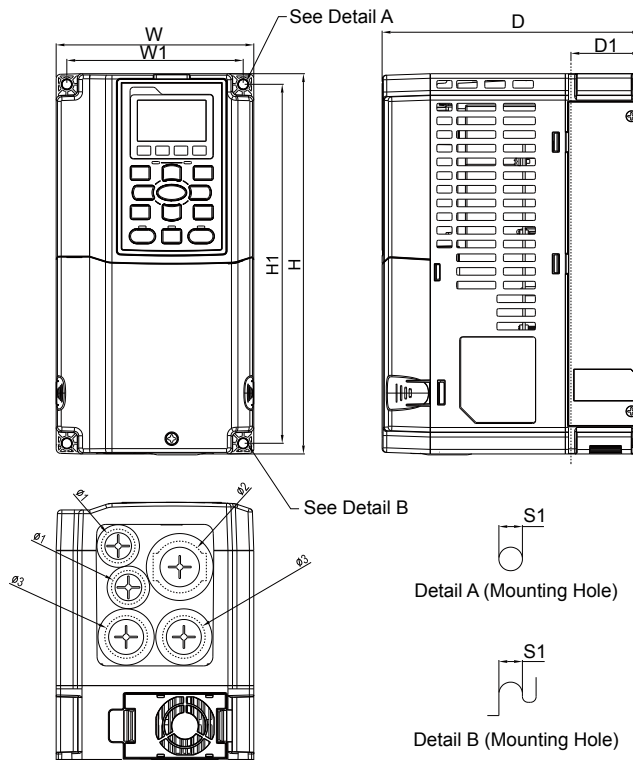

MODEL

VFD007CP23A-21	VFD007CP4EA-21
VFD015CP23A-21	VFD015CP4EB-21
VFD022CP23A-21	VFD022CP4EB-21
VFD037CP23A-21	VFD037CP4EB-21
VFD055CP23A-21	VFD040CP4EA-21
VFD007CP43A-21	VFD055CP4EB-21
VFD015CP43B-21	VFD075CP4EB-21
VFD022CP43B-21	VFD015CP53A-21
VFD037CP43B-21	VFD022CP53A-21
VFD040CP43A-21	VFD037CP53A-21
VFD055CP43B-21	
VFD075CP43B-21	

Frame		W	H	D	W1	H1	D1*	Ø	Ø1	Ø2	Ø3
A	mm	130.0	250.0	170.0	116.0	236.0	45.8	6.2	22.2	34.0	28.0
	inch	5.12	9.84	6.69	4.57	9.29	1.80	0.24	0.87	1.34	1.10

*D1: Flange mount.

Frame B

MODEL

VFD075CP23A-21
 VFD110CP23A-21
 VFD150CP23A-21
 VFD110CP43B-21
 VFD150CP43B-21
 VFD185CP43B-21
 VFD110CP4EB-21
 VFD150CP4EB-21
 VFD185CP4EB-21
 VFD055CP53A-21
 VFD075CP53A-21
 VFD110CP53A-21
 VFD150CP53A-21

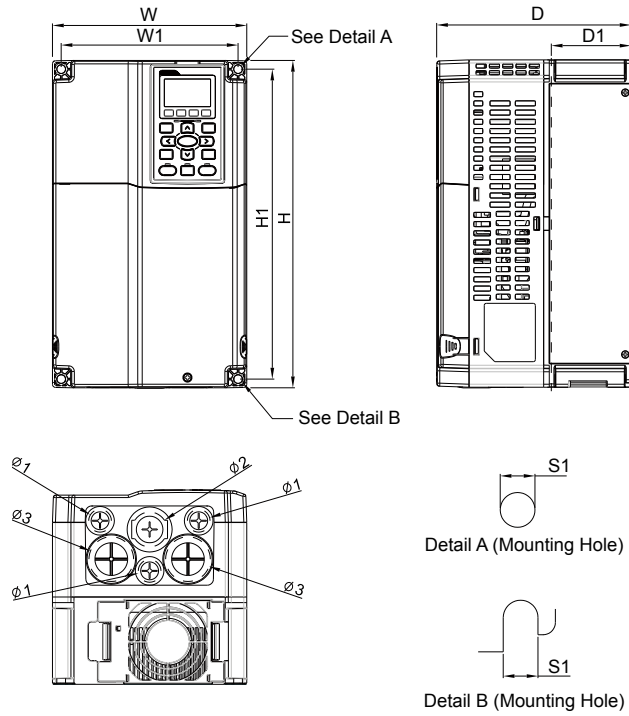

Frame	W	H	D	W1	H1	D1*	S1	$\phi 1$	$\phi 2$	$\phi 3$	
B1	mm	190.0	320.0	190.0	173.0	303.0	77.9	8.5	22.2	34.0	43.8
	inch	7.48	12.60	7.48	6.81	11.93	3.07	0.33	0.87	1.34	1.72

*D1: Flange mount.

Frame C

MODEL

VFD185CP23A-21
 VFD220CP23A-21
 VFD300CP23A-21
 VFD220CP43A-21
 VFD300CP43B-21
 VFD370CP43B-21
 VFD220CP4EA-21
 VFD300CP4EB-21
 VFD370CP4EB-21
 VFD185CP63A-21
 VFD220CP63A-21
 VFD300CP63A-21
 VFD370CP63A-21

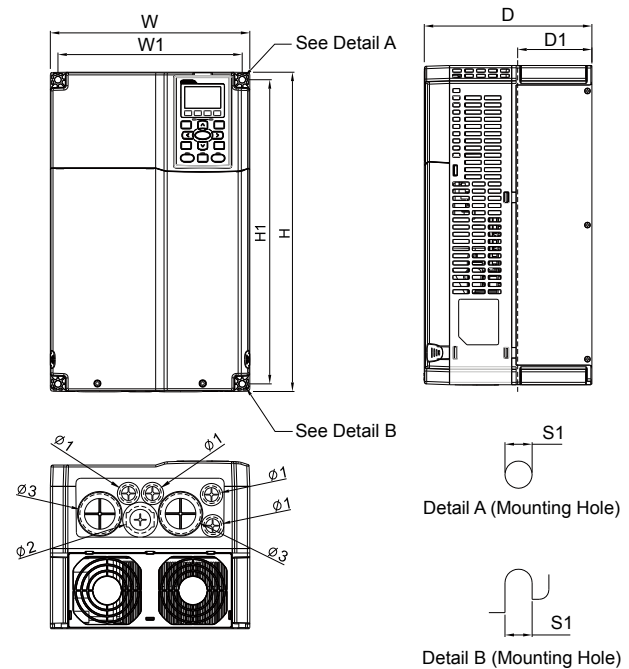

Frame	W	H	D	W1	H1	D1*	S1	$\phi 1$	$\phi 2$	$\phi 3$
C1	mm	250.0	400.0	231.0	381.0	92.9	8.5	22.2	34.0	50.0
	inch	9.84	15.75	8.27	9.09	15.00	3.66	0.33	0.87	1.97

*D1: Flange mount.

Frame D1

MODEL FRAME_D1

VFD370CP23A-00
VFD450CP23A-00
VFD750CP43B-00
VFD900CP43A-00
VFD450CP63A-00
VFD550CP63A-00

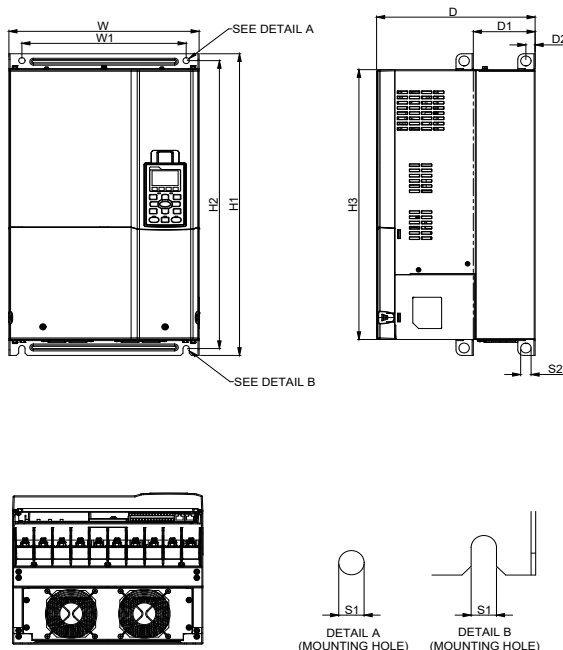

Frame	W	H	D	W1	H1	H2	H3	D1*	D2	S1	S2	Ø1	Ø2	Ø3	
D1	mm	330.0	-	275.0	285.0	550.0	525.0	492.0	107.2	16.0	11.0	18.0	-	-	-
	inch	12.99	-	10.83	11.22	21.65	20.67	19.37	4.22	0.63	0.43	0.71	-	-	-

*D1: Flange mount.

Frame D2

MODEL FRAME_D2

VFD370CP23A-21
VFD450CP23A-21
VFD750CP43B-21
VFD900CP43A-21
VFD450CP63A-21
VFD550CP63A-21

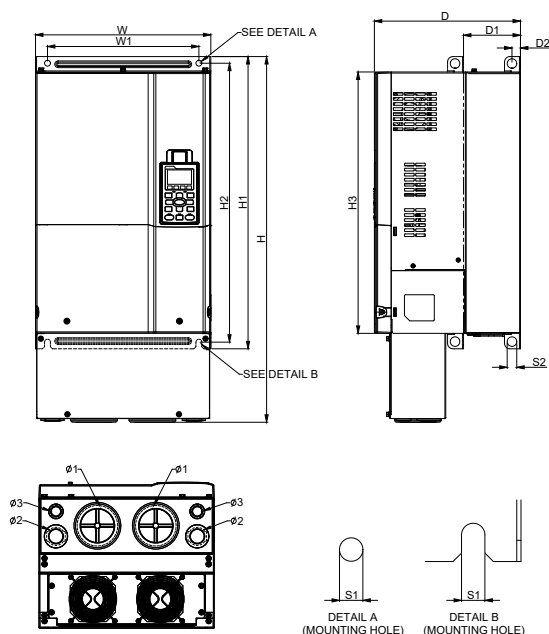

Frame	W	H	D	W1	H1	H2	H3	D1*	D2	S1	S2	Ø1	Ø2	Ø3	
D2	mm	330.0	688.3	275.0	285.0	550.0	525.0	492.0	107.2	16.0	11.0	18.0	76.2	34.0	22.0
	inch	12.99	27.10	10.83	11.22	21.65	20.67	19.37	4.22	0.63	0.43	0.71	3.00	1.34	0.87

*D1: Flange mount.

Frame D0-1

MODEL
FRAME_D0-1

VFD450CP43S-00
VFD550CP43S-00

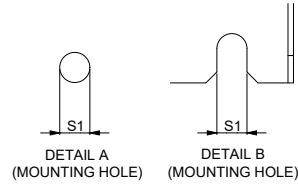
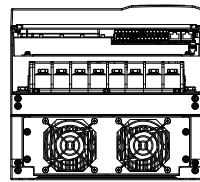
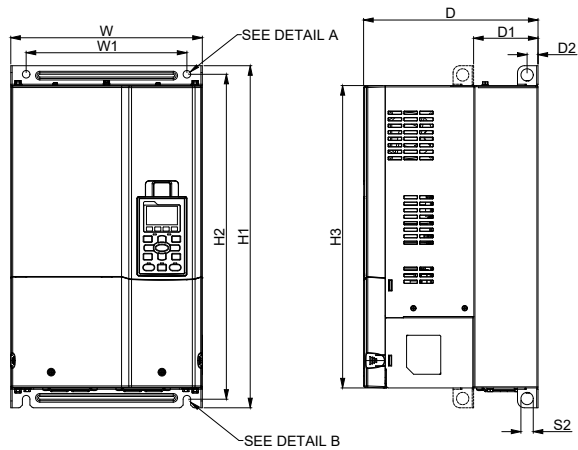

Frame		W	H	D	W1	H1	H2	H3	D1*	D2	S1	S2
D0-1	mm	280.0	-	255.0	235.0	500.0	475.0	442.0	94.2	16.0	11.0	18.0
	inch	11.02	-	10.04	9.25	19.69	18.70	17.40	3.71	0.63	0.43	0.71

*D1: Flange mount.

Frame D0-2

MODEL
FRAME_D0-2

VFD450CP43S-21
VFD550CP43S-21

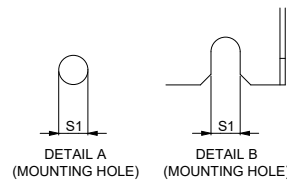
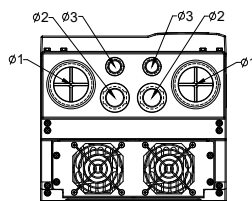
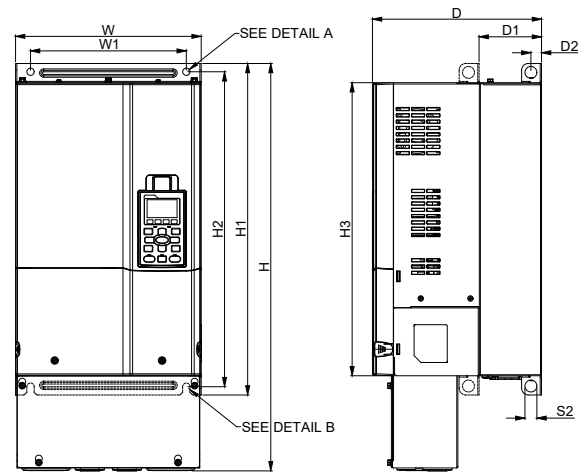

Frame		W	H	D	W1	H1	H2	H3	D1*	D2	S1	S2	Ø1	Ø2	Ø3
D0-2	mm	280.0	614.4	255.0	235.0	500.0	475.0	442.0	94.2	16.0	11.0	18.0	62.7	34.0	22.0
	inch	11.02	24.19	10.04	9.25	19.69	18.70	17.40	3.71	0.63	0.43	0.71	2.47	1.34	0.87

*D1: Flange mount.

Frame E1

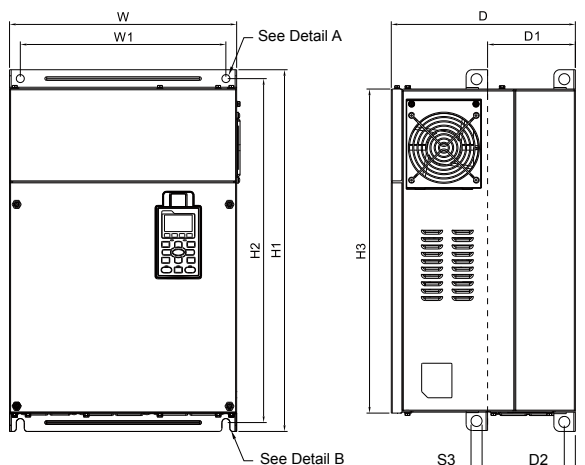

MODEL

VFD550CP23A-00	VFD750CP63A-00
VFD750CP23A-00	VFD900CP63A-00
VFD900CP23A-00	VFD1100CP63A-00
VFD1100CP43A-00	VFD1320CP63A-00
VFD1320CP43B-00	

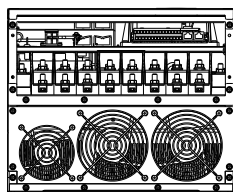

Frame		W	H	D	W1	H1	H2	H3	D1*	D2	S1	S2	S3	Ø1	Ø2	Ø3
E1	mm	370.0	-	300.0	335.0	589.0	560.0	528.0	143.0	18.0	13.0	13.0	18.0	-	-	-
	inch	14.57	-	11.81	13.19	23.19	22.05	20.80	5.63	0.71	0.51	0.51	0.71	-	-	-

*D1: Flange mount.

Frame E2

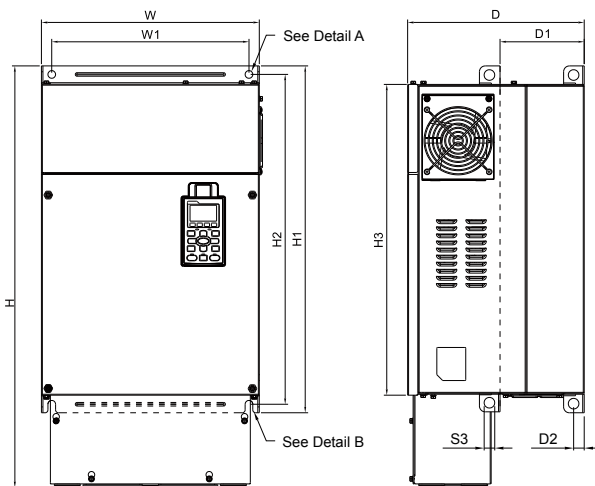

MODEL

VFD550CP23A-21	VFD750CP63A-21
VFD750CP23A-21	VFD900CP63A-21
VFD900CP23A-21	VFD1100CP63A-21
VFD1100CP43A-21	VFD1320CP63A-21
VFD1320CP43B-21	

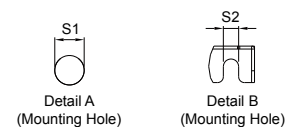
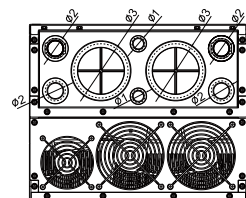

Frame		W	H	D	W1	H1	H2	H3	D1*	D2	S1	S2	S3	Ø1	Ø2	Ø3
E2	mm	370.0	715.8	300.0	335.0	589.0	560.0	528.0	143.0	18.0	13.0	13.0	18.0	22.0	34.0	92.0
	inch	14.57	28.18	11.81	13.19	23.19	22.05	20.80	5.63	0.71	0.51	0.51	0.71	0.87	1.34	3.62

*D1: Flange mount.

Frame F1

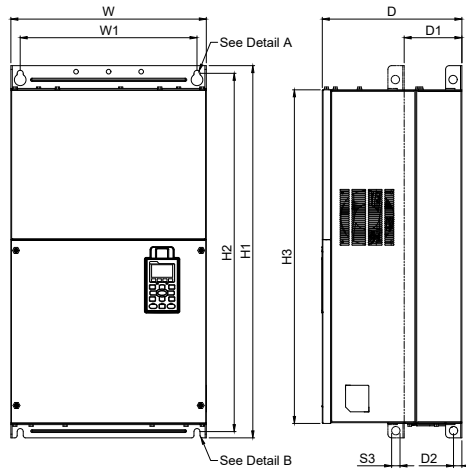

MODEL

VFD1600CP43A-00
 VFD1850CP43B-00
 VFD1600CP63A-00
 VFD2000CP63A-00

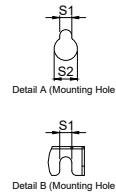
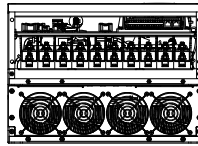

Frame		W	H	D	W1	H1	H2	H3	D1*	D2	S1	S2	S3	Ø1	Ø2	Ø3
F1	mm	420.0	-	300.0	380.0	800.0	770.0	717.0	124.0	18.0	13.0	25.0	18.0	-	-	-
	inch	16.54	-	11.81	14.96	31.50	30.32	28.23	4.88	0.71	0.51	0.98	0.71	-	-	-

*D1: Flange mount.

Frame F2

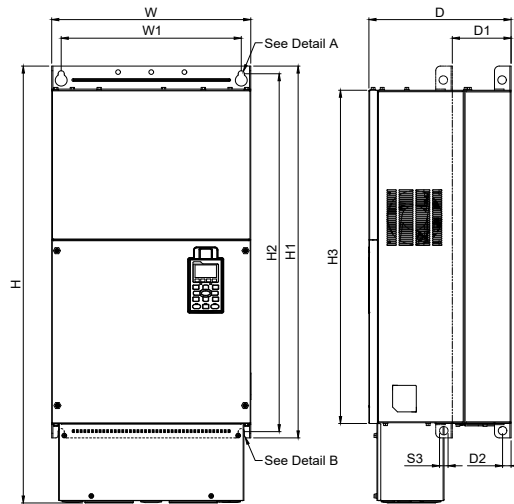

MODEL

VFD1600CP43A-21
 VFD1850CP43B-21
 VFD1600CP63A-21
 VFD2000CP63A-21

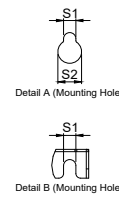
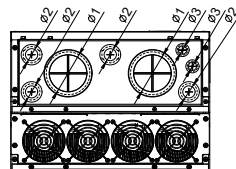

Frame		W	H	D	W1	H1	H2	H3	D1*	D2	S1	S2	S3	Ø1	Ø2	Ø3
F2	mm	420.0	940.0	300.0	380.0	800.0	770.0	717.0	124.0	18.0	13.0	25.0	18.0	92.0	35.0	22.0
	inch	16.54	37.00	11.81	14.96	31.50	30.32	28.23	4.88	0.71	0.51	0.98	0.71	3.62	1.38	0.87

*D1: Flange mount.

Frame G1

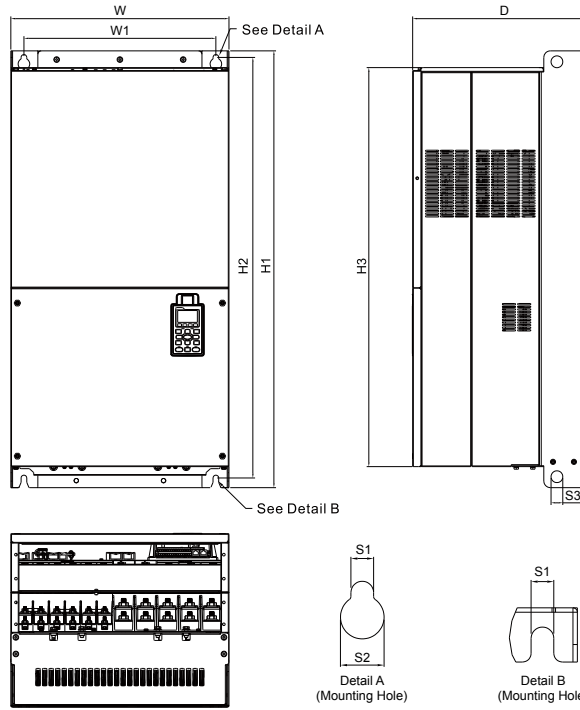

MODEL

- VFD2000CP43A-00
- VFD2200CP43A-00
- VFD2500CP43A-00
- VFD2800CP43A-00
- VFD2500CP63A-00
- VFD3150CP63A-00

Frame		W	H	D	W1	H1	H2	H3	S1	S2	S3	Ø1	Ø2	Ø3
G1	mm	500.0	-	397.0	440.0	1000.0	963.0	913.6	13.0	26.5	27.0	-	-	-
	inch	19.69	-	15.63	217.32	39.37	37.91	35.97	0.51	1.04	1.06	-	-	-

Frame G2

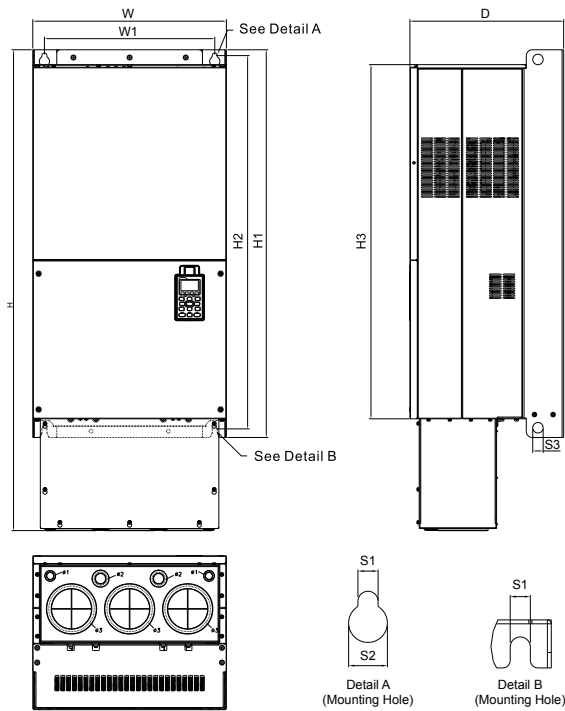

MODEL

- VFD2000CP43A-21
- VFD2200CP43A-21
- VFD2500CP43A-21
- VFD2800CP43A-21
- VFD2500CP63A-21
- VFD3150CP63A-21

Frame		W	H	D	W1	H1	H2	H3	S1	S2	S3	Ø1	Ø2	Ø3
G2	mm	500.0	1240.2	397.0	440.0	1000.0	963.0	913.6	13.0	26.5	27.0	22.0	34.0	117.5
	inch	19.69	48.83	15.63	217.32	39.37	37.91	35.97	0.51	1.04	1.06	0.87	1.34	4.63

Frame H1

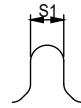
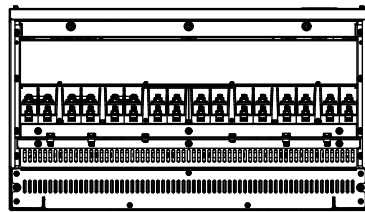
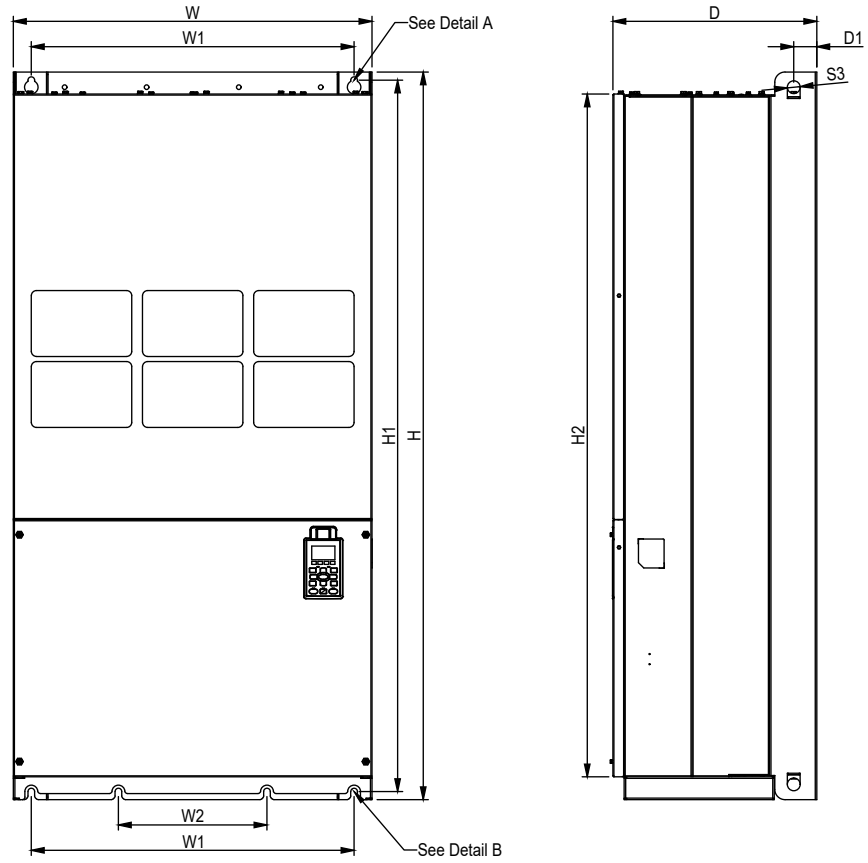

See Detail A(Mounting Hole)

See Detail B(Mounting Hole)

MODEL

- VFD3150CP43A-00
- VFD3550CP43A-00
- VFD4000CP43A-00
- VFD5000CP43A-00
- VFD5600CP43A-00
- VFD6300CP43A-00

Frame	W	H	D	W1	W2	W3	W4	W5	W6	H1	H2	H3	H4
H1	mm	700.0	1435.0	398.0	630.0	290.0	-	-	-	1403.0	1346.6	-	-
	inch	27.56	56.5	15.67	24.80	11.42	-	-	-	55.24	53.02	-	-
Frame	H5	D1	D2	D3	D4	D5	D6	S1	S2	S3	Ø1	Ø2	Ø3
H1	mm	-	45.0	-	-	-	-	13.0	26.5	25.0	-	-	-
	inch	-	1.77	-	-	-	-	0.51	1.04	0.98	-	-	-

Frame H3

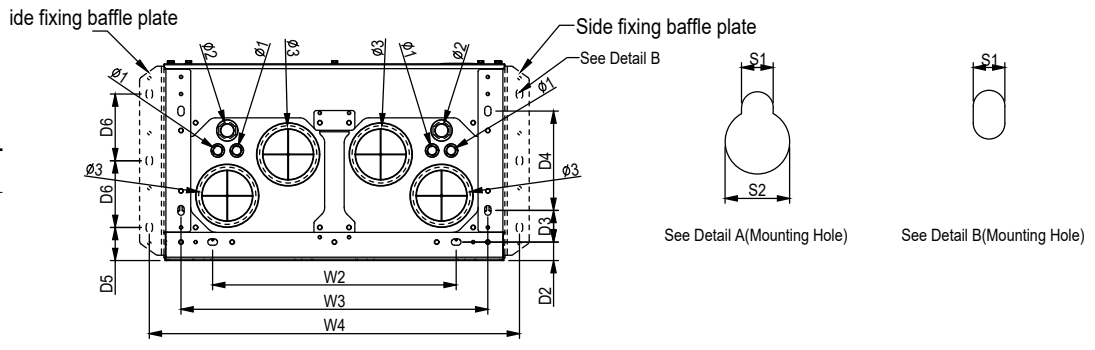
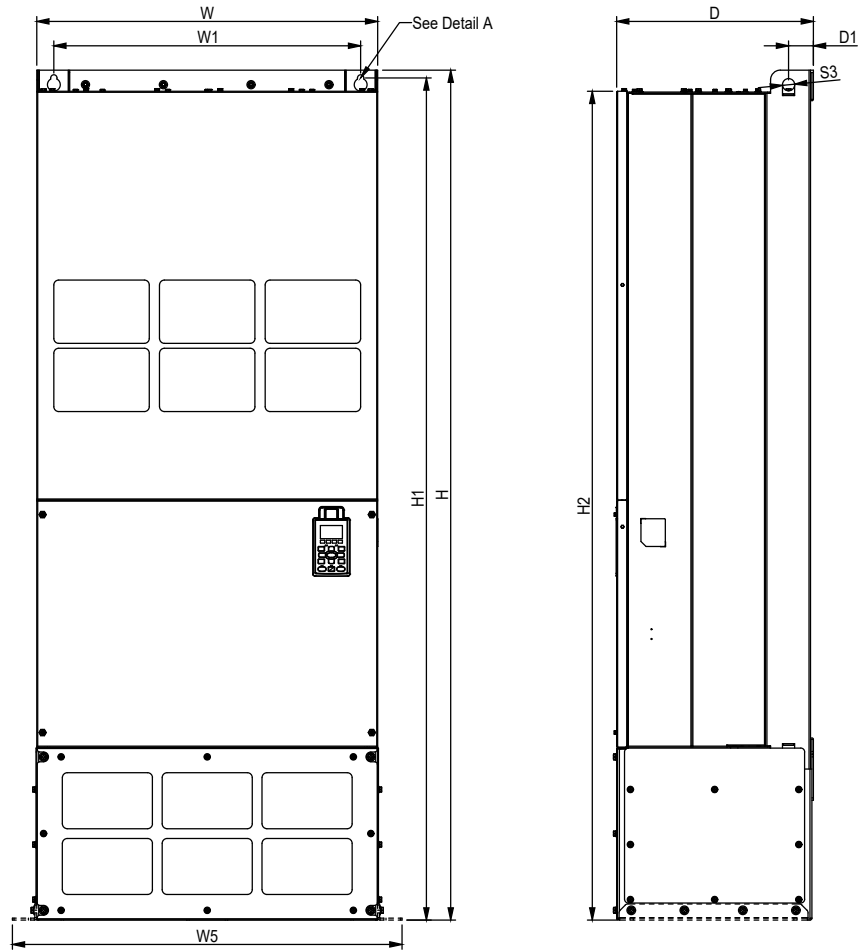

MODEL

- VFD3150CP43C-21
- VFD3550CP43C-21
- VFD4000CP43C-21
- VFD5000CP43C-21
- VFD5600CP43C-21
- VFD6300CP43C-21

Frame	W	H	D	W1	W2	W3	W4	W5	W6	H1	H2	H3	H4
H3	mm	700.0	1745.0	404.0	630.0	500.0	630.0	760.0	-	1729.0	1701.6	-	-
	inch	27.56	68.70	15.91	24.80	19.69	24.80	29.92	-	68.07	66.99	-	-
Frame	H5	D1	D2	D3	D4	D5	D6	S1	S2	S3	Ø1	Ø2	Ø3
H3	mm	-	51.0	38.0	65.0	68.0	137.0	13.0	26.5	25.0	22.0	34.0	117.5
	inch	-	2.0	1.50	2.56	2.68	5.4	0.51	1.04	0.98	0.87	1.34	4.63

690 V Frame H1

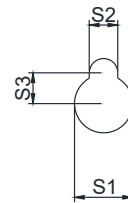
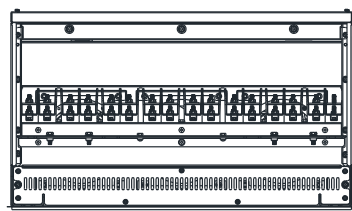
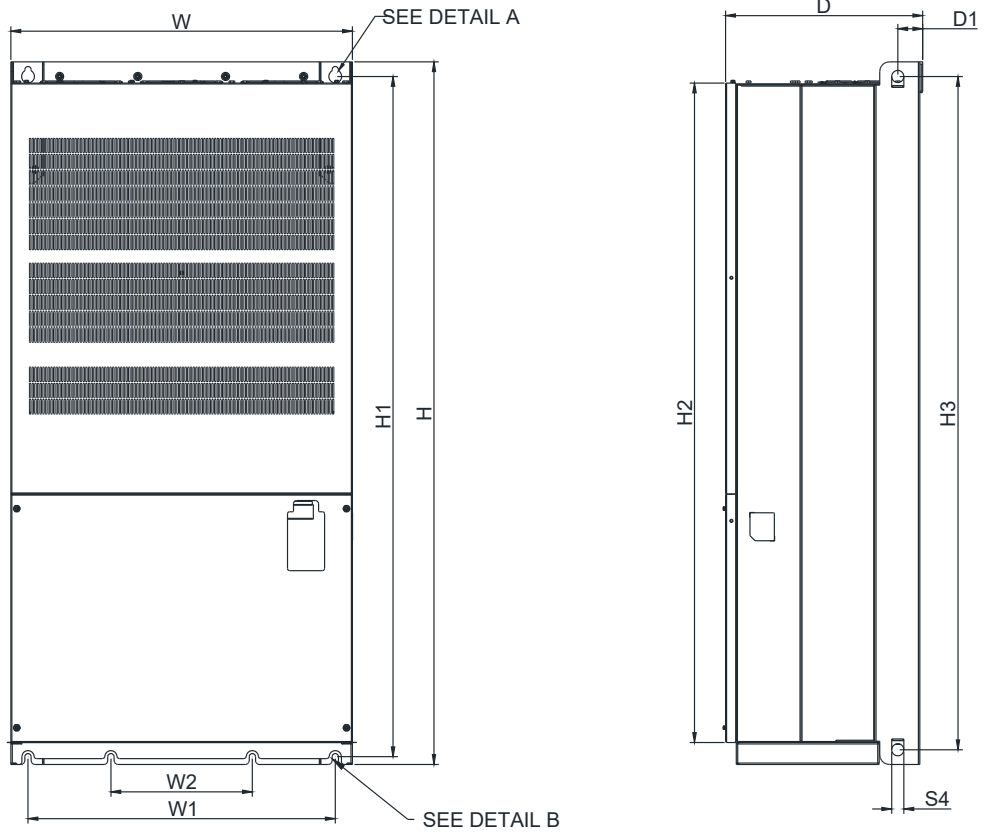

MODEL
690V FRAME_H1

- VFD4000CP63A-00
- VFD4500CP63A-00
- VFD5600CP63A-00
- VFD6300CP63A-00

DETAIL A
(MOUNTING HOLE)

DETAIL B
(MOUNTING HOLE)

Frame		W	H	D	W1	W2	W3	W4	W5	W6	H1	H2	H3	H4
H1	mm	700.0	1435.0	398.0	630.0	290.0	-	-	-	-	1389.0	1346.6	1375.0	-
	inch	27.56	56.5	15.67	24.8	11.42	-	-	-	-	54.68	53.02	54.13	-
Frame		H5	D1	D2	D3	D4	D5	D6	S1	S2	S3	S4		
H1	mm	-	45.0	-	-	-	-	-	26.5	13.0	14.0	25.0		
	inch	-	1.77	-	-	-	-	-	1.04	0.51	0.55	0.98		

690 V Frame H2

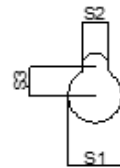
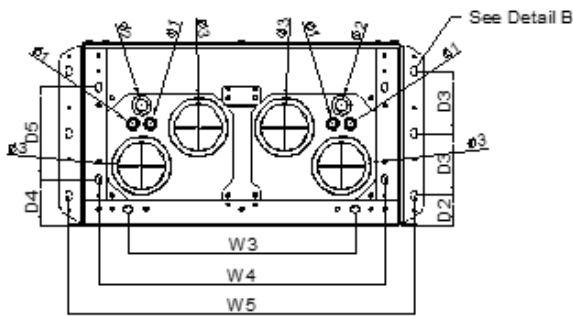
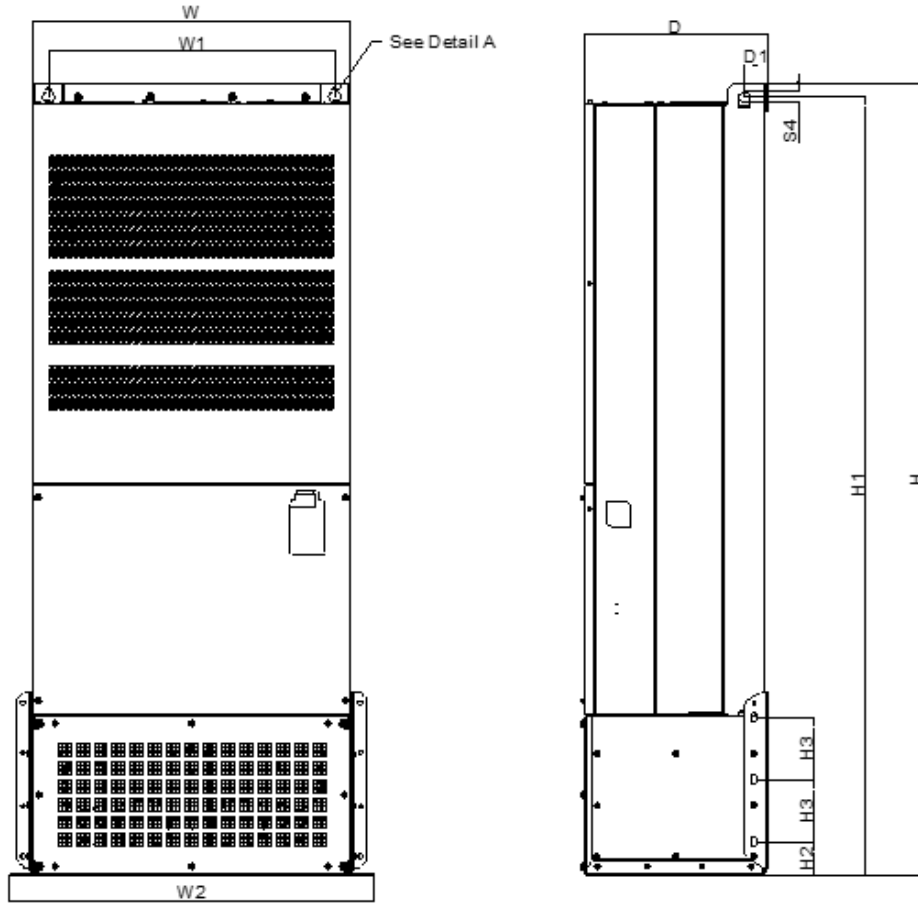

DETAILA
(MOUNTING HOLE)

DETAIL B
(MOUNTING HOLE)

MODEL
690V FRAME_H2

- VFD4000CP63A-21
- VFD4500CP63A-21
- VFD5600CP63A-21
- VFD6300CP63A-21

Frame	W	H	D	W1	W2	W3	W4	W5	W6	H1	H2	H3	H4	H5	
H2	mm	700.0	1745.0	404.0	630.0	800.0	500.0	630.0	760.0	-	1715.0	74.5	137.0	-	-
	inch	27.56	68.70	15.91	24.8	31.5	19.69	24.8	29.92	-	67.52	2.93	5.39	-	-
Frame	D1	D2	D3	D4	D5	D6	S1	S2	S3	S4	S5	Ø1	Ø2	Ø3	
H2	mm	51.0	68.0	137.0	103.0	204.0	-	26.5	13.0	14.0	25.0	13.0	22.0	34.0	117.5
	inch	2.01	2.68	5.39	4.06	8.03	-	1.04	0.51	0.55	0.98	0.51	0.87	1.34	4.63

Accessories

Relay Extension Card

▪ EMC-R6AA

	Terminals	Descriptions
	RA10~RA15 RC10~RC15	Refer to Pr. 02-36~Pr. 02-41 for multi-function output selection Resistive load: 3A (N.O.)/250 V _{AC} 5A (N.O.)/30 V _{DC} Inductive load (COS 0.4) 1.2A (N.O.)/250 V _{AC} 2.0A (N.O.)/30 V _{DC} It is used to output each monitor signal, such as for drive in operation, frequency attained or overload indication.

Analog I/O Extension Card

▪ EMC-A22A

	Terminals	Description
	AVI10 AVI11	Refer to Pr. 14-00~Pr. 14-01 for function selection (input), and Pr. 14-18~Pr. 14-19 for mode selection Two sets of AVI port for AVI or ACI switch: SSW3 (AVI10) and SSW4 (AVI11) AVI: Input 0~10V ACI: Input 0~20 mA/4~20 mA
	AFM10 AFM11	Refer to Pr. 14-12~Pr. 14-13 for function selection (output), and Pr. 14-36~Pr. 14-37 for mode selection Two sets of AFM port for AVO or ACO switch: SSW1 (AFM10) and SSW2 (AFM11) AVO: Output 0~10V ACO: Output 0~20.0 mA/4.0~20.0 mA
	ACM	Analog signal common terminal

I/O Extension Card

▪ EMC-D611A

	Terminals	Descriptions
	AC	AC power common for multi-function input terminal (Neutral)
	MI10~MI15	Refer to Pr. 02-26~Pr. 02-31 for multi-function input selection Input voltage: 100~130 V _{AC} ; Input frequency: 57~63 Hz Input impedance: 27 K Ω Terminal response time: ON: 10 ms; OFF: 20 ms

I/O Extension Card

▪ EMC-D42A

	Terminals	Descriptions
	COM	Common for multi-function input terminals Select SINK (NPN)/SOURCE (PNP) in J1 jumper/external power supply
	MI10~MI13	Refer to Pr. 02-26~Pr. 02-29 to program the multi-function inputs MI10~MI13 Internal power is applied from terminal E24: +24 V _{DC} \pm 5% 200 mA, 5 W External power +24 V _{DC} : max. voltage 30 V _{DC} , min. voltage 19 V _{DC} , 30 W ON: the activation current is 6.5 mA; OFF: leakage current tolerance is 10 μ A
	MO10~MO11	Multi-function output terminals (photocoupler) Duty-cycle: 50%; Max. output frequency: 100 Hz Max. current: 50 mA; Max. voltage: 48 V _{DC}
	MXM	Common for multi-function output terminals MO10, MO11 (photocoupler) Max. 48 V _{DC} 50 mA

24V Power Shift Card

EMC-BPS01

Terminals	Descriptions
 24V GND	Allows operation of network system, PLC function and partial functions when the AC motor drive is power off Input power: 24 V _{DC} ± 5% Maximum input current: 0.5A Note: Do not connect the control terminal +24V (Digital control signal common: SOURCE) directly to the EMC-BPS01 input terminal 24V. Do not connect control terminal GND directly to the EMC-BPS01 input terminal GND.

CANopen Card

EMC-COP01

RJ-45 Pin	Pin name	Definition
1	CAN_H	CAN_H bus line (dominant high)
2	CAN_L	CAN_L bus line (dominant low)
3	CAN_GND	Ground/0V/V-
6	CAN_GND	Ground/0V/V-



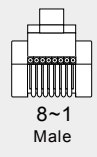

8~1 Male

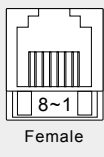

8~1 Female

EtherNet/IP, Modbus TCP Card

CMC-EIP01 / CMC-EIP02 NEW



Features

- ▶ Supports max. 32 words input and 32 words output of I/O connection
- ▶ User-defined parameter mapping
- ▶ IP Filter, basic firewall function
- ▶ Supports DLR ring nodes
*Applicable to CMC-EIP02

Network Interface

Network Protocol	DHCP, BOOTP, EtherNet/IP, Modbus TCP	Interface	RJ-45
Transmission Speed	10/100 Mbps	Number of Ports	1(CMC-EIP01) / 2(CMC-EIP02)
Transmission Method	I/O connection / Explicit message	Transmission Cable	Category 5e shielding
Transmission Distance	100m, extension is allowed via switch		

BACnet Card

eZVFD-CC NEW



Features

- ▶ Supports native BACnet protocol Rev 12
- ▶ Supports BACnet/IP, BACnet over Ethernet communication protocols
- ▶ Dual port Ethernet supports daisy-chaining multiple VFD devices
- ▶ Maps VFD I/O terminals as BACnet I/O
- ▶ Fully programmable in GCL+
- ▶ Setup and configure using Delta Controls facility management software enteliWEB
- ▶ Real-time clock with supercap power backup

eZVFD Connector

Interface	Dual Port RJ45
Transmission Method	Ethernet
Transmission Cable	Shielded CAT 5e/6

eZVFD Communication

Transmission Speed	10/100 Base-T
Network Protocol	BACnet/IP, BACnet Ethernet
BACnet Protocol	Rev 12
Device Addressing	Software Addressed

Accessories

PROFINET Card

▪ CMC-PN01 NEW



Features

- ▶ Supports PROFINET IO device
- ▶ Supports synchronous data transmission and synchronous parameter access
- ▶ Provides GSDML file for PROFINET communication

Network Interface

Interface	RJ-45	Transmission Cable	Category 5e shielding 100M
Number of Ports	2 Ports	Transmission Speed	10/100 Mbps auto-negotiate
Transmission Method	IEEE 802.3	Network Protocol	PROFINET

PROFIBUS DP Card

▪ CMC-PD01



Features

- ▶ Supports PZD control data exchange
- ▶ Supports PKW polling AC motor drive parameters
- ▶ Supports user diagnosis function
- ▶ Supports remote I/O function
- ▶ Baud (auto-detection): max. 12Mbps

PROFIBUS DP Connector

Interface	DB9 connector
Transmission Method	High-speed RS-485
Transmission Cable	Shielded twisted pair cable
Electrical Isolation	500 V _{DC}

Communication

Message Type	Cyclic data exchange
Module Name	CMC-PD01
GSD Document	DELA08DB.GSD
Company ID	08DB (HEX)
Serial Transmission Speed Supported (auto-detection)	9.6 Kbps; 19.2 Kbps; 93.75 Kbps; 187.5 Kbps; 125 Kbps; 250 Kbps; 500 Kbps; 1.5 Mbps; 3 Mbps; 6 Mbps; 12 Mbps (bits per second)

DeviceNet Card

▪ CMC-DN01



Features

- ▶ Based on the high-speed communication interface of Delta HSSP protocol, able to conduct immediate control of an AC motor drive
- ▶ Supports Group 2 only connection and polling I/O data exchange
- ▶ Supports max. 32 words input / 32 words output and remote I/O function for I/O mapping
- ▶ Node address and serial transmission speed can be set up on AC motor drive
- ▶ Power supplied from AC motor drive

DeviceNet Connector

Interface	5-Pin 5.08mm Pluggable Connector
Transmission Method	CAN
Transmission Cable	Shielded twisted pair cable (with 2 power cables)
Transmission Speed	125 Kbps, 250 Kbps, 500 Kbps and extendable serial transmission speed mode
Network Protocol	DeviceNet protocol

DeviceNet Connector

Interface	50-Pin communication terminal
Transmission Method	SPI communication
Terminal Function	1. Communicating with AC motor drive 2. Transmitting power supply from AC motor drive
Communication Protocol	Delta HSSP protocol

Delta Standard Fieldbus Cables

Delta Cables	Part Number	Description	Length
CANopen Cable	UC-CMC003-01A	CANopen cable, RJ45 connector	0.3m
	UC-CMC005-01A	CANopen cable, RJ45 connector	0.5m
	UC-CMC010-01A	CANopen cable, RJ45 connector	1m
	UC-CMC015-01A	CANopen cable, RJ45 connector	1.5m
	UC-CMC020-01A	CANopen cable, RJ45 connector	2m
	UC-CMC030-01A	CANopen cable, RJ45 connector	3m
	UC-CMC050-01A	CANopen cable, RJ45 connector	5m
	UC-CMC100-01A	CANopen cable, RJ45 connector	10m
	UC-CMC200-01A	CANopen cable, RJ45 connector	20m
DeviceNet Cable	UC-DN01Z-01A	DeviceNet cable	305m
	UC-DN01Z-02A	DeviceNet cable	305m
EtherNetCable	UC-EMC003-02A	EtherNet cable, Shielding	0.3m
	UC-EMC005-02A	EtherNet cable, Shielding	0.5m
	UC-EMC010-02A	EtherNet cable, Shielding	1m
	UC-EMC020-02A	EtherNet cable, Shielding	2m
	UC-EMC050-02A	EtherNet cable, Shielding	5m
	UC-EMC100-02A	EtherNet cable, Shielding	10m
	UC-EMC200-02A	EtherNet cable, Shielding	20m
PROFIBUS Cable	UC-PF01Z-01A	PROFIBUS DP cable	305m

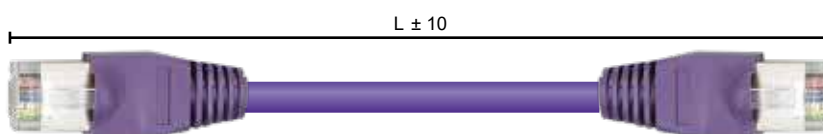

CANopen / DeviceNet TAP Breakout Boxes

Part Number	Description
TAP-CN01	1 in 2 out, built-in 121Ω terminal resistor
TAP-CN02	1 in 4 out, built-in 121Ω terminal resistor
TAP-CN03	1 in 4 out, RJ45 connector, built-in 121Ω terminal resistor

Unit: mm [inch]



TAP-CN01











TAP-CN02



TAP-CN03

Ordering Information

Frame Size		Power Range	Models			
Frame A		230 V: 0.75 ~ 5.5 kW	VFD007CP23A-21 VFD015CP23A-21 VFD022CP23A-21 VFD037CP23A-21 VFD055CP23A-21	VFD007CP43A-21 VFD015CP43B-21 VFD022CP43B-21 VFD037CP43B-21 VFD040CP43A-21 VFD055CP43B-21 VFD075CP43B-21	VFD007CP4EA-21 VFD015CP4EB-21 VFD022CP4EB-21 VFD037CP4EB-21 VFD040CP4EA-21 VFD055CP4EB-21 VFD075CP4EB-21	VFD015CP53A-21 VFD022CP53A-21 VFD037CP53A-21
		460 V: 0.75 ~ 7.5 kW				
		575 V: 1.5 ~ 3.7 kW				
Frame B		230 V: 7.5 ~ 15 kW	VFD075CP23A-21 VFD110CP23A-21 VFD150CP23A-21	VFD110CP43B-21 VFD150CP43B-21 VFD185CP43B-21	VFD110CP4EB-21 VFD150CP4EB-21 VFD185CP4EB-21	VFD055CP53A-21 VFD075CP53A-21 VFD110CP53A-21 VFD150CP53A-21
		460 V: 11 ~ 18.5 kW				
		575 V: 5.5 ~ 15 kW				
Frame C		230 V: 18.5 ~ 30 kW	VFD185CP23A-21 VFD220CP23A-21 VFD300CP23A-21	VFD220CP43A-21 VFD300CP43B-21 VFD370CP43B-21	VFD220CP4EA-21 VFD300CP4EB-21 VFD370CP4EB-21	VFD185CP63A-21 VFD220CP63A-21 VFD300CP63A-21 VFD370CP63A-21
		460 V: 22 ~ 37 kW				
		690 V: 18.5 ~ 37 kW				
Frame D		230 V: 37 ~ 45 kW	Frame D1: VFD370CP23A-00 VFD450CP23A-00 VFD750CP43B-00 VFD900CP43A-00	Frame D2: VFD370CP23A-21 VFD450CP23A-21 VFD750CP43B-21 VFD900CP43A-21		Frame D1: VFD450CP63A-00 VFD550CP63A-00
		460 V: 45 ~ 90 kW	Frame D0-1: VFD450CP43S-00 VFD550CP43S-00	Frame D0-2: VFD450CP43S-21 VFD550CP43S-21		Frame D2: VFD450CP63A-21 VFD550CP63A-21
		690 V: 55 ~ 75 kW				
Frame E		230 V: 55 ~ 90 kW	Frame E1: VFD550CP23A-00 VFD750CP23A-00 VFD900CP23A-00 VFD1100CP43A-00 VFD1320CP43B-00	Frame E2: VFD550CP23A-21 VFD750CP23A-21 VFD900CP23A-21 VFD1100CP43A-21 VFD1320CP43B-21		Frame E1: VFD750CP63A-00 VFD900CP63A-00 VFD1100CP63A-00 VFD1320CP63A-00
		460 V: 110 ~ 132 kW				Frame E2: VFD750CP63A-21 VFD900CP63A-21 VFD1100CP63A-21 VFD1320CP63A-21
		690 V: 75 ~ 132 kW				
Frame F		460 V: 160 ~ 185 kW	Frame F1: VFD1600CP43A-00 VFD1850CP43B-00	Frame F2: VFD1600CP43A-21 VFD1850CP43B-21		Frame F1: VFD1600CP63A-00 VFD2000CP63A-00
		690 V: 160 ~ 200 kW				Frame F2: VFD1600CP63A-21 VFD2000CP63A-21
Frame G		460 V: 220 ~ 280 kW	Frame G1: VFD2000CP43A-00 VFD2200CP43A-00 VFD2500CP43A-00 VFD2800CP43A-00	Frame G2: VFD2000CP43A-21 VFD2200CP43A-21 VFD2500CP43A-21 VFD2800CP43A-21		Frame G1: VFD2500CP63A-00 VFD3150CP63A-00
		690 V: 250 ~ 315 kW				Frame G2: VFD2500CP63A-21 VFD3150CP63A-21

Frame Size		Power Range	Models	
Frame H		460V: 315~ 630kW	Frame H1: VFD3150CP43A-00 VFD3550CP43A-00 VFD4000CP43A-00 VFD5000CP43A-00 VFD5600CP43A-00 VFD6300CP43A-00	Frame H3: VFD3150CP43C-21 VFD3550CP43C-21 VFD4000CP43C-21 VFD5000CP43C-21 VFD5600CP43C-21 VFD6300CP43C-21
Frame H (690 V Model)		690V: 400~ 630kW		Frame H1: VFD4000CP63A-00 VFD4500CP63A-00 VFD5600CP63A-00 VFD6300CP63A-00 Frame H2: VFD4000CP63A-21 VFD4500CP63A-21 VFD5600CP63A-21 VFD6300CP63A-21

Model Name

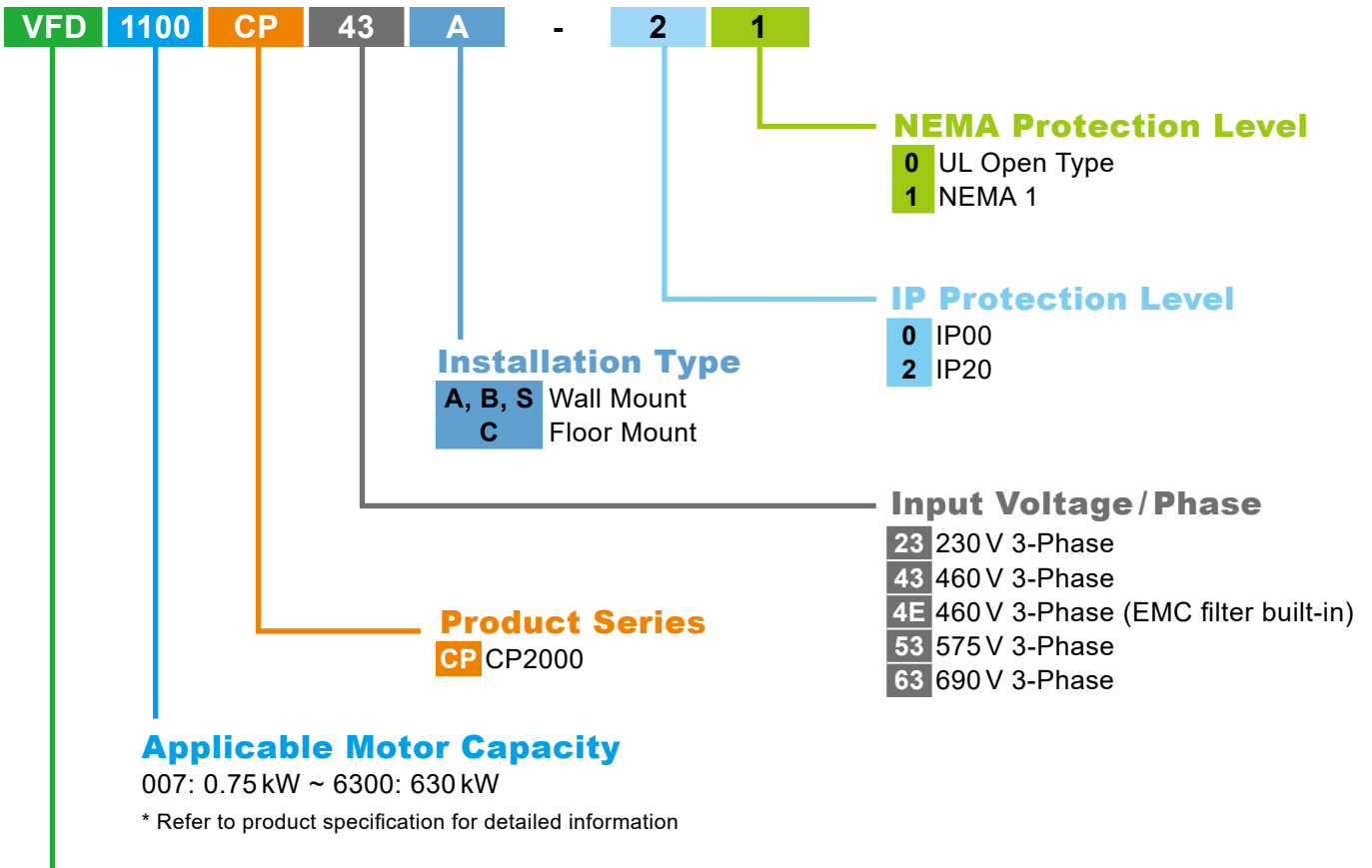



Attention

Standard Motors

Used with 400V Standard Motors

It is recommended to add an AC output reactor when using with a 400V standard motor to prevent damage to motor insulation.

Torque Characteristics and Temperature Rise

When a standard motor is drive controlled, the motor temperature will be higher than with DOL operation.

Please reduce the motor output torque when operating at low speeds to compensate for less cooling efficiency.

For continuous constant torque at low speeds, external forced motor cooling is recommended.

Vibration

When the motor drives the machine, resonances may occur, including machine resonances. Abnormal vibration may occur when operating a 2-pole motor at 60Hz or higher.

Noise

When a standard motor is drive controlled, the motor noise will be higher than with DOL operation.

To lower the noise, please increase the carrier frequency of the drive. The motor fan can be very noisy when the motor speed exceeds 60Hz.

Special Motors

High-speed Motor

To ensure safety, please try the frequency setting with another motor before operating the high-speed motor at 120Hz or higher.

Explosion-proof Motor

Please use a motor and drive that comply with explosion-proof requirements.

Submersible Motor & Pump

The rated current is higher than that of a standard motor.

Please check before operation and select the capacity of the AC motor drive carefully. The motor temperature characteristics differ from a standard motor, please set the motor thermal time constant to a lower value.

Brake Motor

When the motor is equipped with a mechanical brake, the brake should be powered by the mains supply. Damage may occur when the brake is powered by the drive output. Please DO NOT drive the motor with the brake engaged.

Gear Motor

In gearboxes or reduction gears, lubrication may be reduced if the motor is continuously operated at low speeds. Please DO NOT operate in this way.

Synchronous Motor

These motors need suitable software for control. Please contact Delta for more information.

Single-phase Motor

Single-phase motors are not suitable for being operated by an AC Motor Drive. Please use a 3-phase motor instead when necessary.

Environmental Conditions

Installation Position

1. The drive is suitable for installation in a place with ambient temperature from -10 to 50[°]C.
2. The surface temperature of the drive and brake resistor will rise under specific operation conditions. Therefore, please install the drive on materials that are noncombustible.
3. Ensure that the installation site complies with the ambient conditions as stated in the manual.

Wiring

Limit of Wiring Distance

For remote operation, please use twist-shielding cable and the distance between the drive and control box should be less than 20m.

Maximum Motor Cable Length

Motor cables that are too long may cause overheating of the drive or current peaks due to stray capacitance.

Please ensure that the motor cable is less than 30m.

If the cable length can't be reduced, please lower the carrier frequency or use an AC reactor.

Choose the Right Cable

Please refer to current value to choose the right cable section with enough capacity or use recommended cables.

Grounding

Please ground the drive completely by using the grounding terminal.

How to Choose the Drive Capacity

Standard Motor

Please select the drive according to applicable motor rated current listed in the drive specification.

Please select the next higher power AC drive in case higher starting torque or quick acceleration/deceleration is needed.

Special Motor

Please select the drive according to: Rated current of the drive > rated current of the motor

Transportation and Storage

Please transport and store the drive in a place that meets environment specifications.

Peripheral Equipment

Molded-Case Circuit Breakers (MCCB)

Please install the recommended MCCB or ELCB in the main circuit of the drive and make sure that the capacity of the breaker is equal to or lower than the recommended one.

Add a Magnetic Contactor(MC) in the Output Circuit

When a MC is installed in the output circuit of the drive to switch the motor to commercial power or other purposes, please make sure that the drive and motor are completely stopped and remove the surge absorbers from the MC before switching it.

Add a Magnetic Contactor (MC) in the Input Circuit

Please only switch the MC ONCE per hour or it may damage the drive. Please use RUN/STOP signal to switch many times during motor operation.

Motor Protection

The thermal protection function of the drive can be used to protect the motor by setting the operation level and motor type (standard motor or variable motor). When using a high-speed motor or a water-cooled motor the thermal time constant should be set to a lower value.

When using a longer cable to connect the motor thermal relay to a motor, high-frequency currents may enter via the stray capacitance. It may result in malfunctioning of the relay as the real current is lower than the setting of thermal relay. Under this condition, please lower the carrier frequency or add an AC reactor to solve this.

DO NOT Use Capacitors to Improve the Power Factor

Use a DC reactor to improve the power factor of the drive. Please DO NOT install power factor correction capacitors on the main circuit of the drive to prevent motor faults due to over current.

Do NOT Use Surge Absorbers

Please DO NOT install surge absorbers on the output circuit of the drive.

Lower the Noise

To ensure compliance with EMC regulations, usually a filter and shielded wiring is used to lower the noise.

Method Used to Reduce the Surge Current

Surge currents may occur in the phase-lead capacitor of the power system, causing an overvoltage when the drive is stopped or at low loads.

It is recommended to add a DC reactor to the drive.



Smarter. Greener. Together.

Industrial Automation Headquarters

Delta Electronics, Inc.

Taoyuan Technology Center
No.18, Xinglong Rd., Taoyuan District,
Taoyuan City 33068, Taiwan
TEL: 886-3-362-6301 / FAX: 886-3-371-6301

Asia

Delta Electronics (Shanghai) Co., Ltd.

No.182 Minyu Rd., Pudong Shanghai, P.R.C.
Post code : 201209
TEL: 86-21-6872-3988 / FAX: 86-21-6872-3996
Customer Service: 400-820-9595

Delta Electronics (Japan), Inc.

Tokyo Office
Industrial Automation Sales Department
2-1-14 Shibadaimon, Minato-ku
Tokyo, Japan 105-0012
TEL: 81-3-5733-1155 / FAX: 81-3-5733-1255

Delta Electronics (Korea), Inc.

Seoul Office
1511, 219, Gasan Digital 1-Ro., Geumcheon-gu,
Seoul, 08501 South Korea
TEL: 82-2-515-5305 / FAX: 82-2-515-5302

Delta Energy Systems (Singapore) Pte Ltd.

4 Kaki Bukit Avenue 1, #05-04, Singapore 417939
TEL: 65-6747-5155 / FAX: 65-6744-9228

Delta Electronics (India) Pvt. Ltd.

Plot No.43, Sector 35, HSIIDC Gurgaon,
PIN 122001, Haryana, India
TEL: 91-124-4874900 / FAX : 91-124-4874945

Delta Electronics (Thailand) PCL.

909 Soi 9, Moo 4, Bangpoo Industrial Estate (E.P.Z),
Pattana 1 Rd., T.Phraksa, A.Muang,
Samutprakarn 10280, Thailand
TEL: 66-2709-2800 / FAX : 662-709-2827

Delta Electronics (Australia) Pty Ltd.

Unit 20-21/45 Normanby Rd., Notting Hill Vic 3168, Australia
TEL: 61-3-9543-3720

Americas

Delta Electronics (Americas) Ltd.

Raleigh Office
P.O. Box 12173, 5101 Davis Drive,
Research Triangle Park, NC 27709, U.S.A.
TEL: 1-919-767-3813 / FAX: 1-919-767-3969

Delta Electronics Brazil

São Paulo Sales Office
Rua Itapeva, 26 - 3º, andar Edifício Itapeva,
One - Bela Vista 01332-000 - São Paulo - SP - Brazil
TEL: 55-12-3932-2300 / FAX: 55-12-3932-237

Delta Electronics International Mexico S.A. de C.V.

Mexico Office
Gustavo Baz No. 309 Edificio E PB 103
Colonia La Loma, CP 54060
Tlalnepantla, Estado de México
TEL: 52-55-3603-9200

EMEA

Headquarters: Delta Electronics (Netherlands) B.V.

Sales: Sales.IA.EMEA@deltaww.com
Marketing: Marketing.IA.EMEA@deltaww.com
Technical Support: iatechnicalsupport@deltaww.com
Customer Support: Customer-Support@deltaww.com
Service: Service.IA.emea@deltaww.com
TEL: +31(0)40 800 3900

BENELUX: Delta Electronics (Netherlands) B.V.

De Witbogt 20, 5652 AG Eindhoven, The Netherlands
Mail: Sales.IA.Benelux@deltaww.com
TEL: +31(0)40 800 3900

DACH: Delta Electronics (Netherlands) B.V.

Coesterweg 45, D-59494 Soest, Germany
Mail: Sales.IA.DACH@deltaww.com
TEL: +49(0)2921 987 0

France: Delta Electronics (France) S.A.

ZI du bois Challand 2, 15 rue des Pyrénées,
Lisses, 91090 Evry Cedex, France
Mail: Sales.IA.FR@deltaww.com
TEL: +33(0)1 69 77 82 60

Iberia: Delta Electronics Solutions (Spain) S.L.U

Ctra. De Villaverde a Vallecas, 265 1º Dcha Ed.
Hormigueras – P.I. de Vallecas 28031 Madrid
TEL: +34(0)91 223 74 20

Carrer Llacuna 166, 08018 Barcelona, Spain

Mail: Sales.IA.Iberia@deltaww.com

Italy: Delta Electronics (Italy) S.r.l.

Via Meda 2-22060 Novedrate(CO)
Piazza Grazioli 18 00186 Roma Italy
Mail: Sales.IA.Italy@deltaww.com
TEL: +39 039 8900365

Russia: Delta Energy System LLC

Vereyskaya Plaza II, office 112 Vereyskaya str.
17 121357 Moscow Russia
Mail: Sales.IA.RU@deltaww.com
TEL: +7 495 644 3240

Turkey: Delta Greentech Elektronik San. Ltd. Sti. (Turkey)

Şerifaii Mah. Hendem Cad. Kule Sok. No:16-A
34775 Ümraniye – İstanbul
Mail: Sales.IA.Turkey@deltaww.com
TEL: + 90 216 499 9910

GCC: Delta Energy Systems AG (Dubai BR)

P.O. Box 185668, Gate 7, 3rd Floor, Hamarain Centre
Dubai, United Arab Emirates
Mail: Sales.IA.MEA@deltaww.com
TEL: +971(0)4 2690148

Egypt + North Africa: Delta Electronics

Unit 318, 3rd Floor, Trivium Business Complex, North 90 street,
New Cairo, Cairo, Egypt
Mail: Sales.IA.MEA@deltaww.com