

## Bluetooth low energy expansion board based on BlueNRG for STM32 Nucleo

Data brief



- X-NUCLEO-IDB04A1 is officially certified as a BTLE 5mW module for Japan Radio Law "TYPE" Certification by Japan government
- RoHS compliant

### Description

The X-NUCLEO-IDB04A1 is a Bluetooth low energy evaluation board to allow expansion of the STM32 Nucleo boards. It is compatible with the Arduino UNO R3 connector layout, and is designed around BlueNRG, a Bluetooth low energy, low power network coprocessor compliant with BTLE 4.0 and the BALF-NRG-01D3, an ultra miniature balun optimized for ST BlueNRG RF IC, which integrates matching network and harmonics filter. The X-NUCLEO-IDB04A1 interfaces with the STM32 MCU via SPI pin, and the user can change the default SPI clock, the SPI chip select and SPI IRQ by changing one resistor on the evaluation board. The excellent performance of BlueNRG and the best matching between BlueNRG and BALF-NRG-01D3, X-NUCLEO-IDB04A1 passed the RF TEST for Japan Radio Law certification with higher margin above the specification values as well as it is FCC certified (FCC ID: S9NIDB04A1).

### Features

- BlueNRG low power, low energy Bluetooth network coprocessor
- BALF-NRG-01D3 balun & harmonic filter
- Free comprehensive development firmware library and example for BlueNRG, compatible with STM32Cube firmware
- Bluetooth low energy 4.0 master and slave compliant
- Compatible with STM32 Nucleo boards
- Equipped with Arduino UNO R3 connector
- Very low power consumption: 7.3 mA RX and 8.2 mA TX at +0 dBm
- Maximum transmission power: +8 dBm
- Excellent receiver sensitivity (-88 dBm)
- X-NUCLEO-IDB04A1 is FCC certified (FCC ID: S9NIDB04A1)

# 1 Formal Notices Required by the U.S. Federal Notices Required by the U.S. Federal Communications Commission (“FCC”)

Any changes or modifications to this equipment not expressly approved by STMicroelectronics may cause harmful interference and void the user’s authority to operate this equipment. This device complies with Part 15 of the FCC Rules. Operation is subject to the following two conditions: (1) this device may not cause harmful interference, and (2) this device must accept any interference received, including any interference that may cause undesired operation. This device uses, generates and radiated radio frequency energy. The radio frequency energy produced by this device is well below the maximum exposure allows by Federal Communications Commission (FCC). The X-NUCLEO-IDB04A1 is FCC certified (FCC ID: S9NIDB04A1).

Figure 1: Functional block diagram

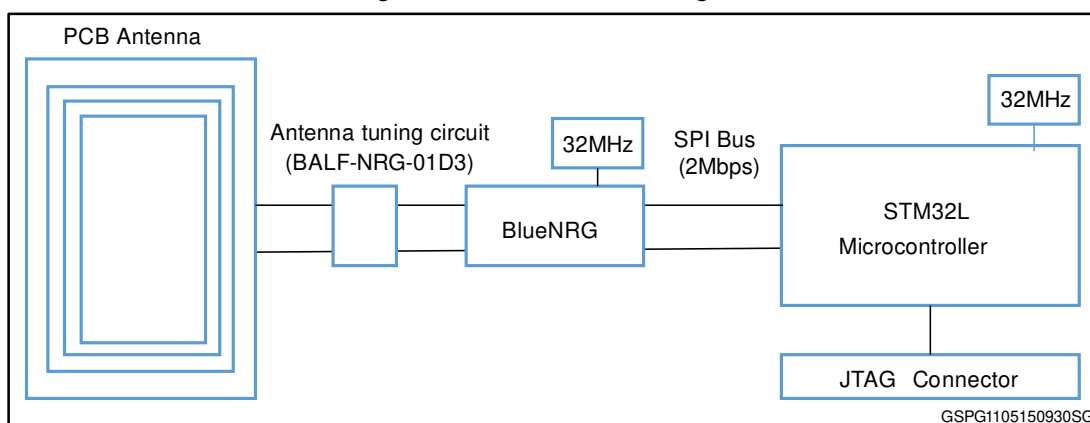

# 2 Schematic diagram

Figure 2: Circuit schematic

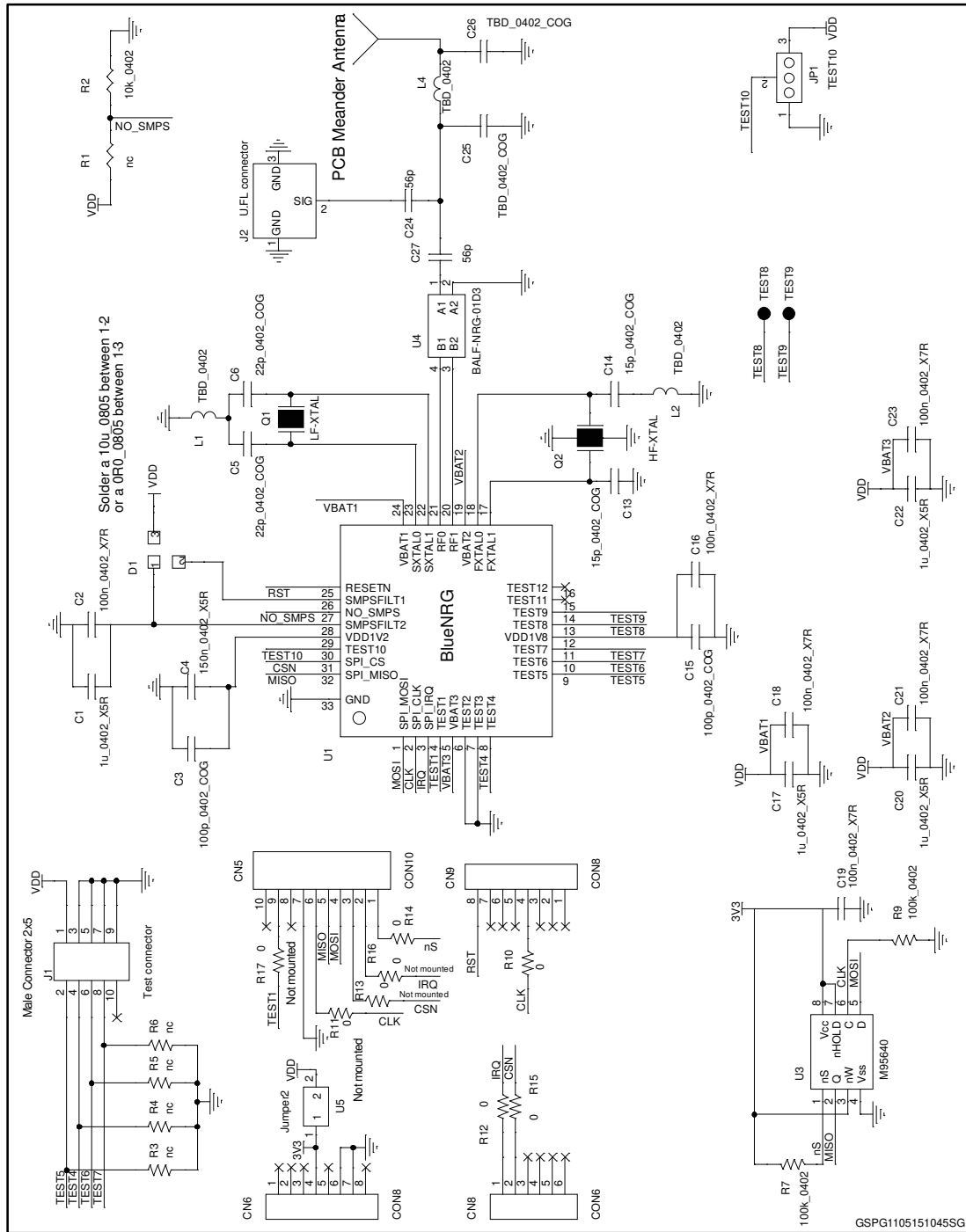

### 3 Revision history

**Table 1: Document revision history**

<b>Date</b>	<b>Rev</b>	<b>Changes</b>
08-May-2014	1	First release.
01-Dec-2014	2	Features and Description in cover page have been updated.
20-May-2015	3	Added new Section 1.

**IMPORTANT NOTICE – PLEASE READ CAREFULLY**

STMicroelectronics NV and its subsidiaries (“ST”) reserve the right to make changes, corrections, enhancements, modifications, and improvements to ST products and/or to this document at any time without notice. Purchasers should obtain the latest relevant information on ST products before placing orders. ST products are sold pursuant to ST’s terms and conditions of sale in place at the time of order acknowledgement.

Purchasers are solely responsible for the choice, selection, and use of ST products and ST assumes no liability for application assistance or the design of Purchasers’ products.

No license, express or implied, to any intellectual property right is granted by ST herein.

Resale of ST products with provisions different from the information set forth herein shall void any warranty granted by ST for such product.

ST and the ST logo are trademarks of ST. All other product or service names are the property of their respective owners.

Information in this document supersedes and replaces information previously supplied in any prior versions of this document.

© 2015 STMicroelectronics – All rights reserved