

- NOTES:
1. ALL PARTS TO BE BULK PACKED UNLESS NOTED.
 2. INSTA CLICK PANEL MOUNT ASSEMBLY IS SUPPLIED WITH CONTACTS INSERTED INTO THE CONNECTOR. ACCEPTS WIRE 12, 14 AND 16 AWG.
 3. ALL DIMENSIONS ARE REFERENCED IN INCHES [MM], WITHIN ± 0.015 UNLESS NOTED.

W 4 X 8 X - X SG - P - 3 XX

CONTACT SIZES
 1' - SIZE #12
 2' - SIZE #20
 3' - SIZE #16

CONTACTS STYLE
 0' - CRIMP
 1' - SOLDER
 2' - PC TAIL

ES - EPOXY FILLED
 00 - NO EPOXY

CONTACTS POSITIONS
 POSITION 2, 3 & 4 (AVAILABLE IN SIZE #12)
 POSITION 4, 5 & 6 (AVAILABLE IN SIZE #16)
 POSOTION 4,5,6,7,8,9,10,11&12 (AVAILABLE IN SIZE #20)

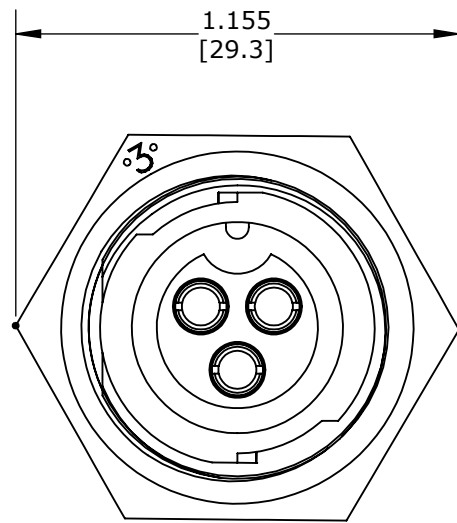

FACE VIEW
 W4181-3SG-P-300
 3 #12 CONTACT STYLE IS SHOWN

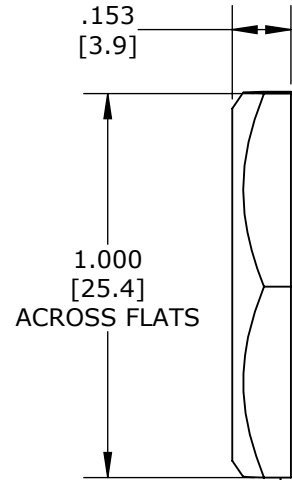

HEX NUT
 MATL: UV THERMOPLASTIC, BLACK

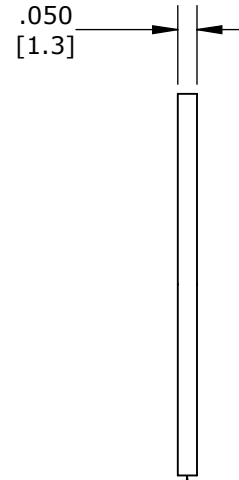

WASHER GASKET
 MATL: RUBBER, BLACK

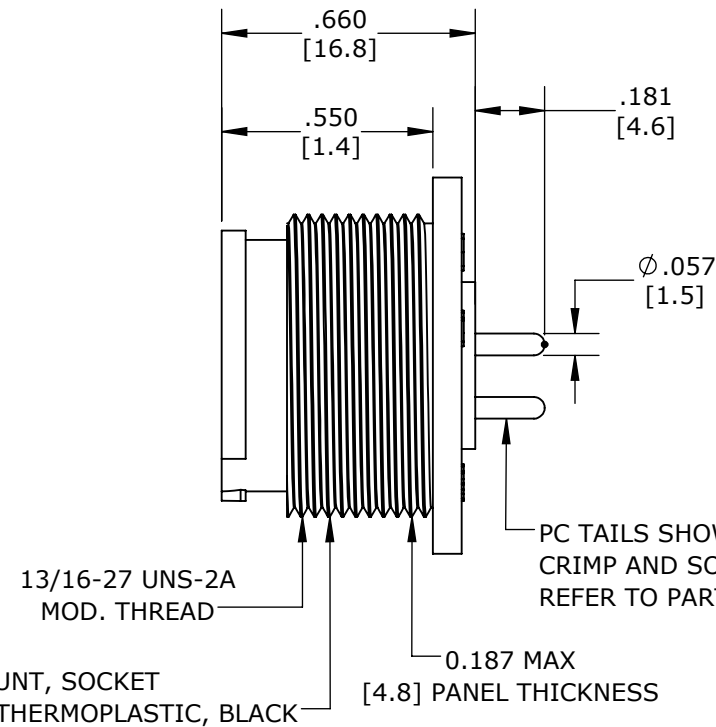

PANEL MOUNT, SOCKET
 MATL: UV THERMOPLASTIC, BLACK

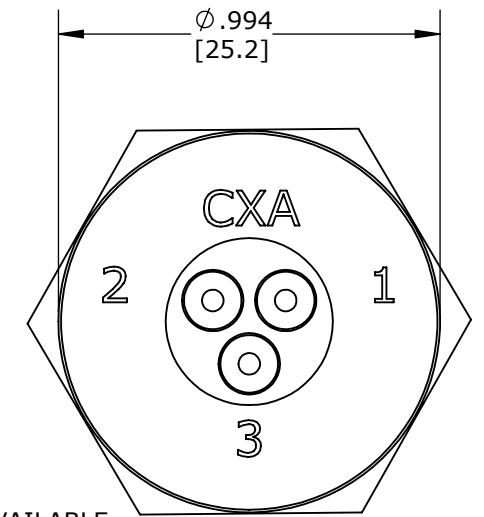

WIRE VIEW
 W4181-3SG-P-300
 3 #12 CONTACT STYLE IS SHOWN

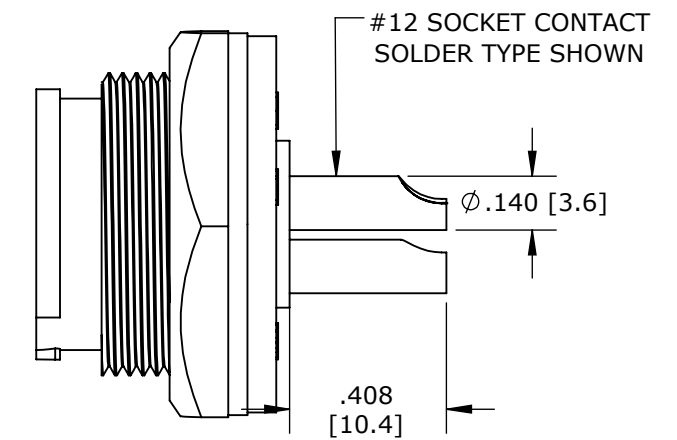

SIDE VIEW SHOWN
 W4182-3SG-P-300

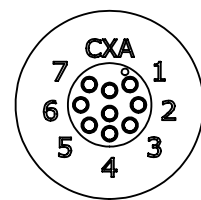

WIRE VIEW
 W4281-9SG-P-300

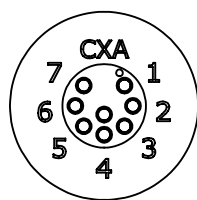

WIRE VIEW
 W4281-8SG-P-300

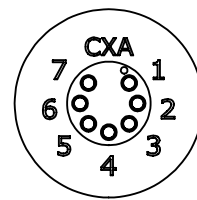

WIRE VIEW
 W4281-7SG-P-300

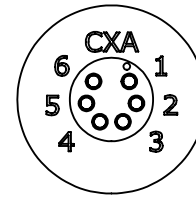

WIRE VIEW
 W4281-6SG-P-300

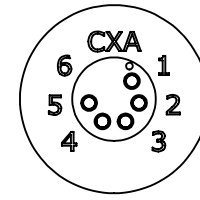

WIRE VIEW
 W4281-5SG-P-300

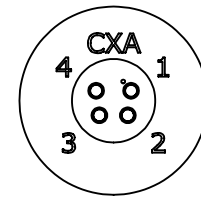

WIRE VIEW
 W4281-4SG-P-300

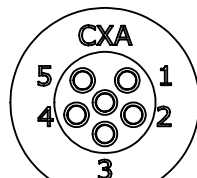

WIRE VIEW
 W4381-6SG-P-300

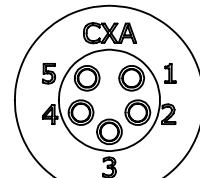

WIRE VIEW
 W4381-5SG-P-300

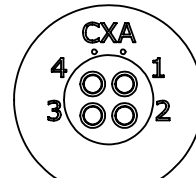

WIRE VIEW
 W4381-4SG-P-300

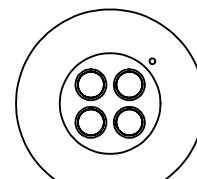

WIRE VIEW
 W4182-4SG-P-300

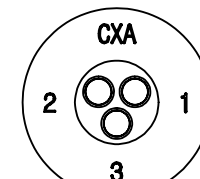

WIRE VIEW
 W4182-3SG-P-300

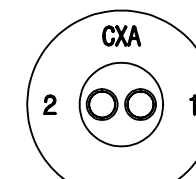

WIRE VIEW
 W4182-2SG-P-300

CUSTOMER APPROVAL

THIS DOCUMENT CONTAINS CONFIDENTIAL INFORMATION PROPRIETARY TO CONXALL CORPORATION. ANY REPRODUCTION, DISCLOSURE, OR USE OF THIS DOCUMENT /INFORMATION IS EXPRESSLY PROHIBITED UNLESS AUTHORIZED IN WRITING BY CONXALL CORPORATION.

APPROVED BY: _____
 DATE: _____

(RoHS COMPLIANT)

0A	AM	03/03/22	CUSTOMER DRAWING
REV.	INIT.	DATE	DESCRIPTION
	AM	03/03/22	
<small>ALL INFORMATION ILLUSTRATED IS THE PROPERTY OF CONXALL CORPORATION. UNAUTHORIZED DUPLICATION OR DISTRIBUTION OF THIS DOCUMENT IS PROHIBITED.</small>			
<small>ALL UNITS ARE IN FEET, INCHES, FRACTION OF INCHES AND DECIMALS. UNLESS OTHERWISE SPECIFIED TOLERANCES: 3 PLACE DECIMALS ±.005 ANGLES ±1° FRACTIONS ±1/16</small>			
<small>APPROVED BY:</small>		<small>TITLE: PANEL CONNECTOR ASSEMBLY (2-4) #12, (4-6) #16, (4-12) #20 SOCKET CONTACTS MULTI CONX INSTA-CLICK STANDARD PRODUCT</small>	
SCALE	SIZE	SHEET	<small>CUSTOMER:</small>
NTS	B	1 OF 1	
FILE:	DIRECTORY:	PART NUMBER:	<small>W4X8X-XSG-P-3XX</small>
FILE NAME	SLW	REV	0A

CUSTOMER PRINT

PART NUMBER: W4X8X-XSG-P-3XX