

NUMBER 66051

©1961 BY AMP INCORPORATED. ALL RIGHTS RESERVED. AMP PRODUCTS COVERED BY PATENTS AND/OR PATENTS PENDING.

REVISIONS				
ZONE	LTR	DESCRIPTION	DATE	APPROVED
E-1		REDRAWN AND REVISED 1678	4-18-68	M.S. ΔH.
F		LOC'S WAS 'AB', DIST 2 WAS 39 9347	11-8-72	JP
G		BRIGHT TIN-LEAD WAS TIN, EA 1818	6-18-81	DS
H		OBSOLETE - 7 & - 8 ECN 53379	11-86	RA
J		REV PER DF-0357	6/15/88	JP

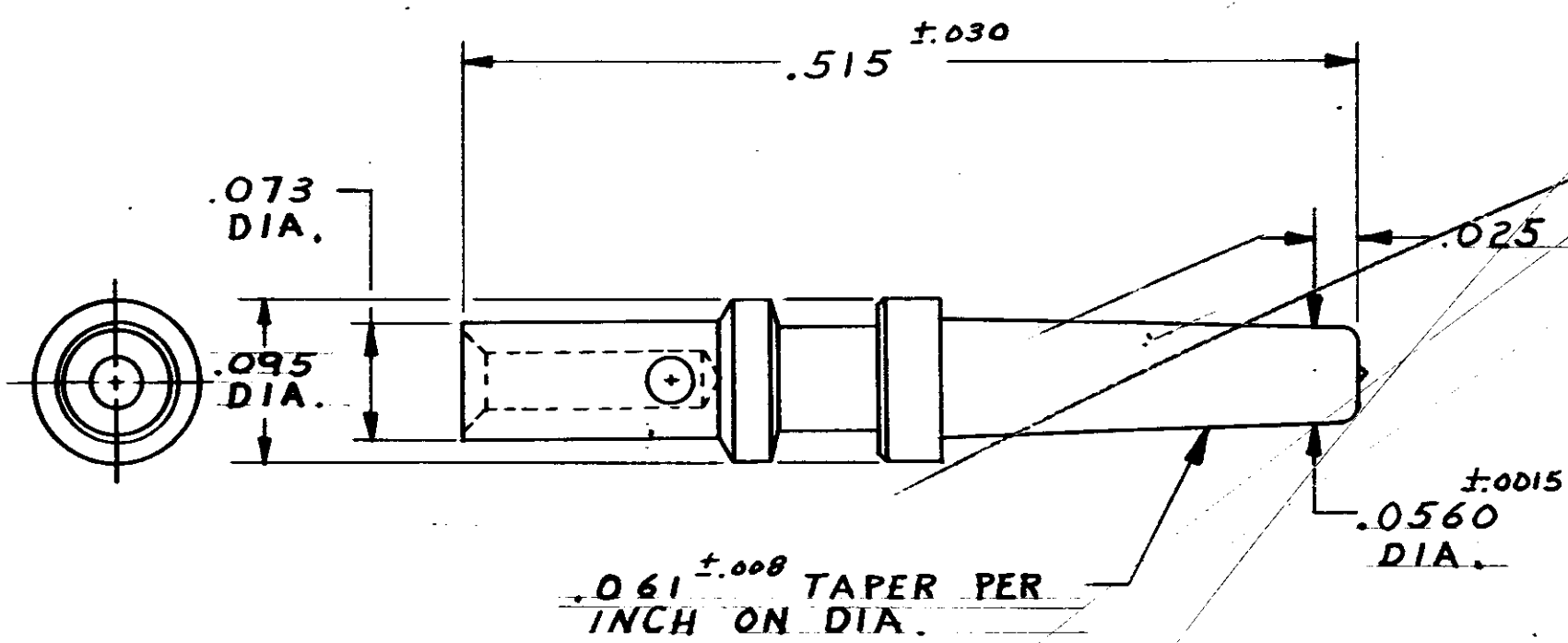

WIRE SIZE: #24-22

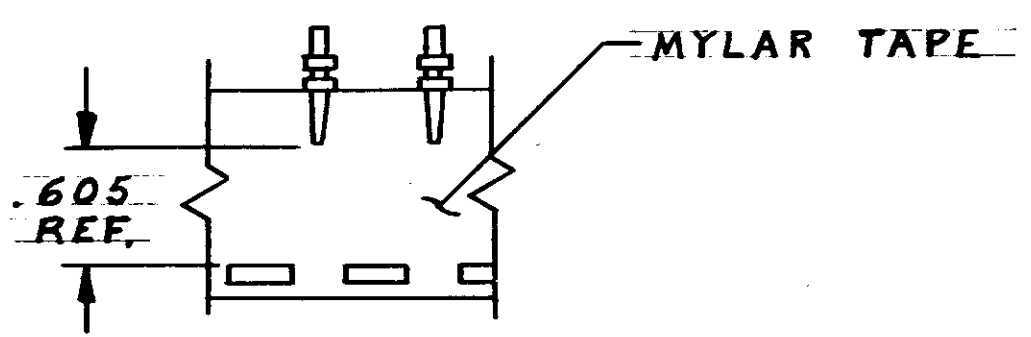

TAPE MOUNTED PART NO.S 66051-7, -8, & -9.

	66051-9	.00003 GOLD OVER .00005 NICKEL
OBSOLETE	66051-8	SILVER -.0002 THICK
	66051-7	BRIGHT TIN-LEAD .0002 THICK
	66051-5	.0002 GOLD OVER .000050 NICKEL
	66051-4	.0001 GOLD OVER .0001 NICKEL
	66051-3	.00003 GOLD OVER .00005 NICKEL
OBSOLETE	66051-2	SILVER -.0002 THICK
	66051-1	BRIGHT TIN-LEAD .0002 THICK
	PART NO.	FINISH

UNLESS OTHERWISE SPECIFIED DIM. ARE IN INCHES. TOLERANCES ON DECIMALS ± .015 ANGLES ± 1° 0'	CONTRACT NO.	AMP INCORPORATED HARRISBURG, PENNSYLVANIA	
	DR <i>M. Smith</i> 4-18-68	NAME PIN, TAPER "53" SERIES	
MATERIAL BRASS	CHK <i>S. Heide</i> 5/10/68	SIZE B	CODE IDENT NO. 00779
	APP'D <i>Abowitz</i> 5/16/68	NUMBER 66051	SCALE 10-1
AMP INFO	DESIGN APP'D	WT CALC	ACTUAL
LOC DF	PRINTED BY JNO	SHEET	
HEAT TREAT	FINISH SEE TABLE		

2 CUSTOMER DRAWING 1