

CKT SIZE	DIM A	DIM B
2	---	.396
	---	10.06
4	.496	.727
	12.60	18.46
5	.661	.892
	16.80	22.66
6	.827	1.057
	21.00	26.86
7	.992	1.223
	25.20	31.06
8	1.157	1.388
	29.40	35.26
9	1.323	1.553
	33.60	39.46
10	1.488	1.719
	37.80	43.66
11	1.654	1.884
	42.00	47.86
12	1.819	2.049
	46.20	52.06

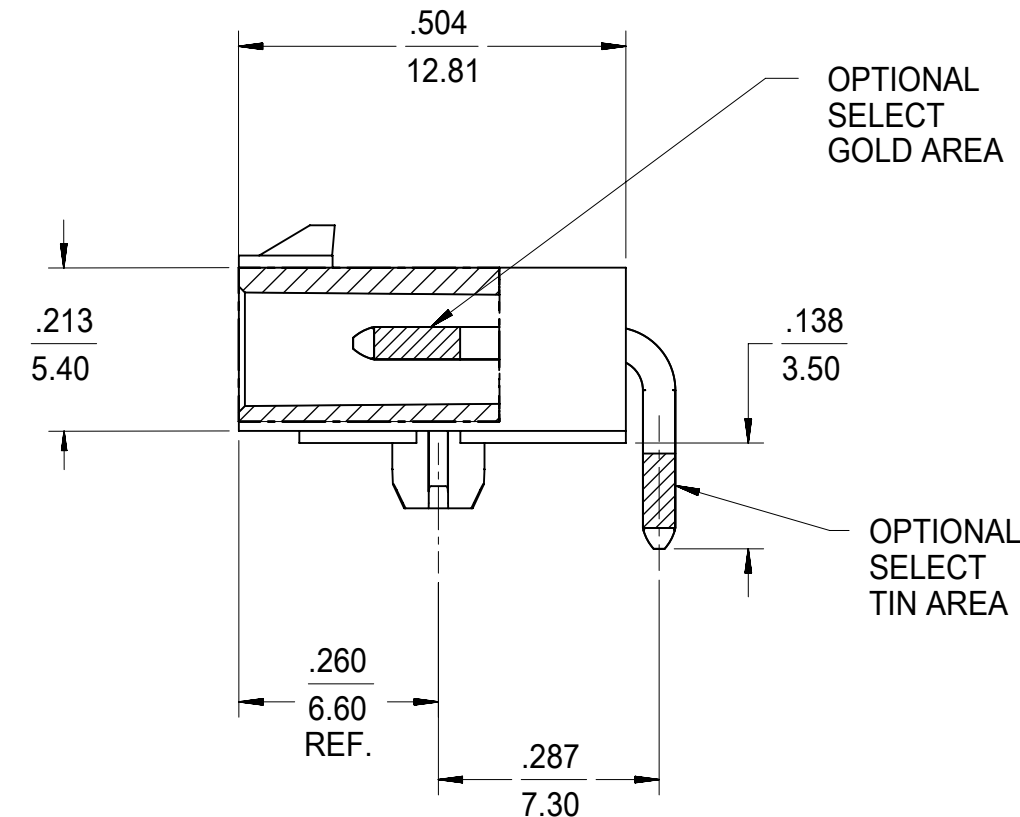
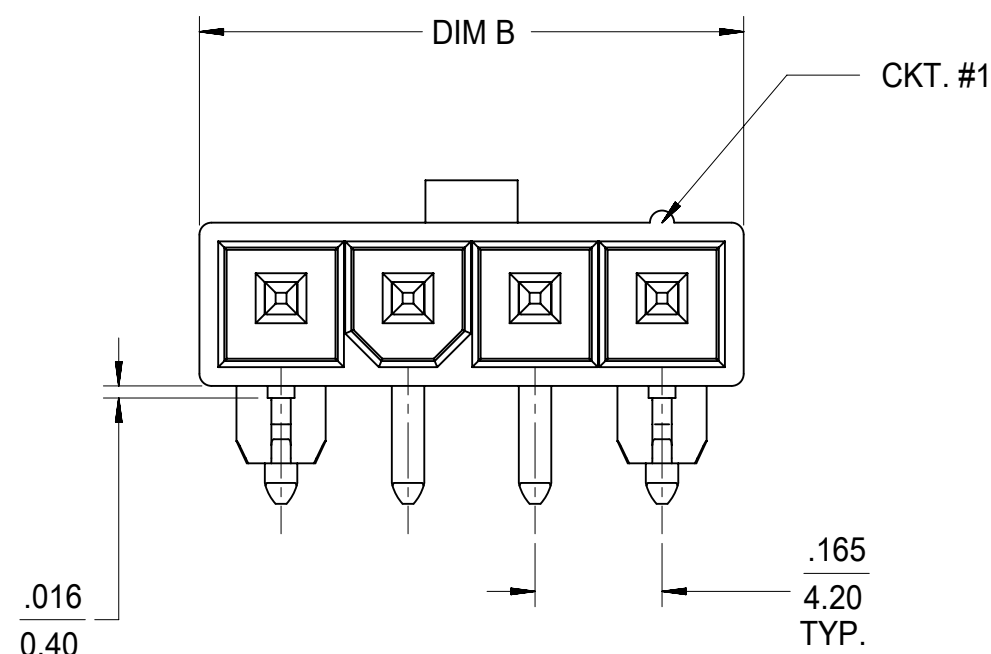
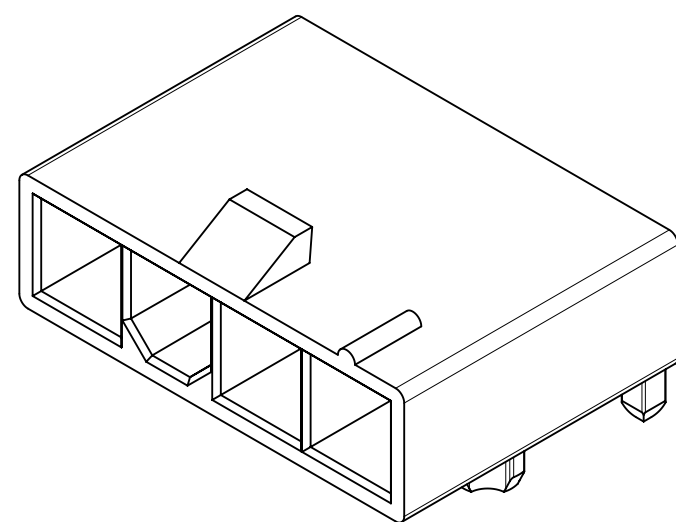

LEGEND:

CKT. SIZE (02-12) → 5569 - ** A ** - *

ASSEMBLY →

MOUNTING & LOCK OPTION: →

8 = PRESS-FIT PEG, POSITIVE LOCK

PLATING OPTION: → (SEE NOTE 3)

MATERIAL OPTION: → (SEE NOTE 1)

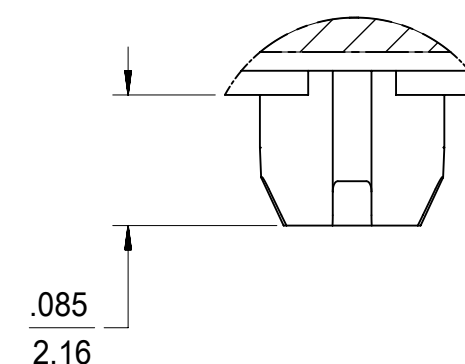
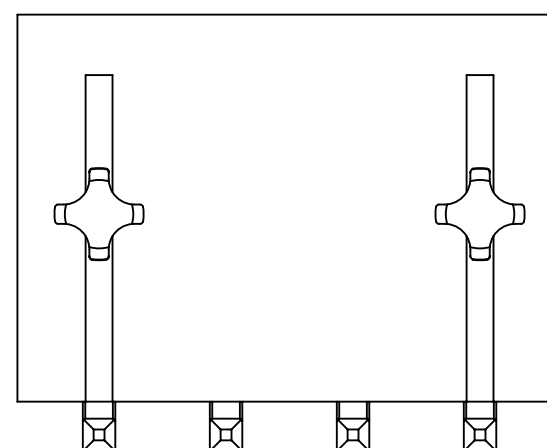
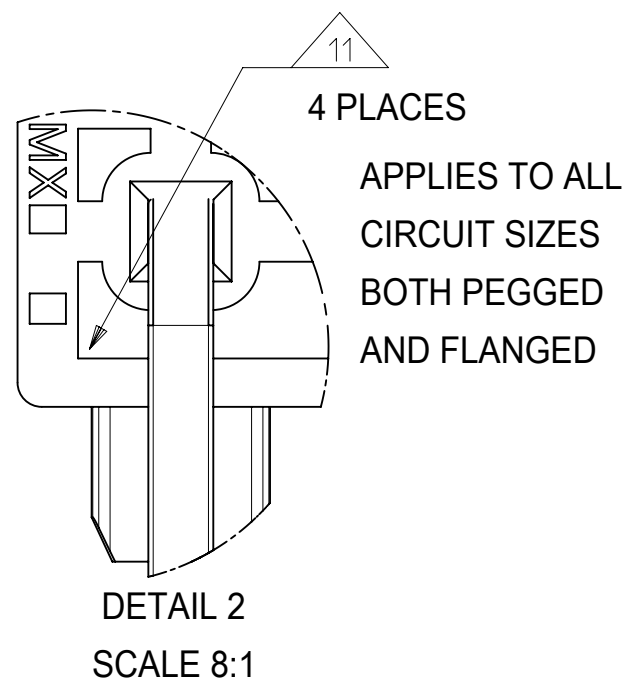
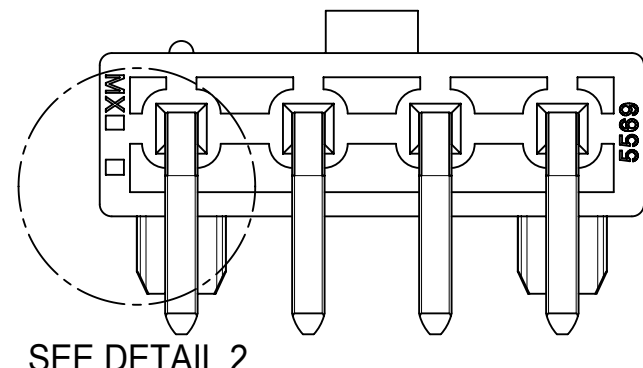

DETAIL 1
SCALE 8:1

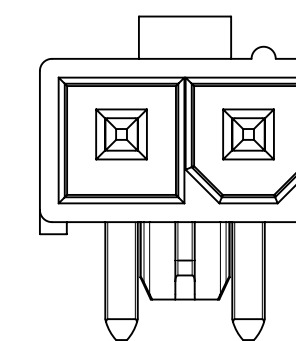

2 CIRCUIT

- NOTES:**
- HOUSING MATERIAL: 130 = LCP, UL94V-0. COLOR: BLACK IEC 60335-1, 5TH EDITION GLOW WIRE CAPABLE
 - TERMINAL MATERIAL: BRASS ALLOY
 - TERMINAL PLATING: "MS" = .000100/0.00254 MIN. MATTE TIN OVER .000050/0.00127 MIN. NICKEL
 - PRODUCT SPECIFICATION: PS-5556-004
 - PART MATES WITH MINI-FIT JR RECEPTACLE SERIES 5557
 - DISCOLORATION IN THE BANDOLIER CARRIER AREA OF THE PIN IS INHERENT TO THE PLATING PROCESS AND IS DUE TO THE MASKING EFFECT OF THE CARRIER. THIS DISCOLORATION IS IN A NON-FUNCTIONAL AREA OF THE PIN AND WILL NOT AFFECT THE PERFORMANCE OF THE HEADER ASSEMBLY.
 - PART CONFORMS TO CLASS "B" REQUIREMENTS OF COSMETIC SPECIFICATION PS-45499-002.
 - CONNECTORS ARE NOT TO BE MATED AND UNMATED WHILE CIRCUITS ARE LIVE.
 - PARTS ARE NOT DESIGNED FOR CURRENT SHARING.
 - PACKAGING: TRAY PACK PER PK-5569-005
 - CORNER CORE-OUTS ARE OPTIONAL AND MAY OR MAY NOT BE PRESENT.

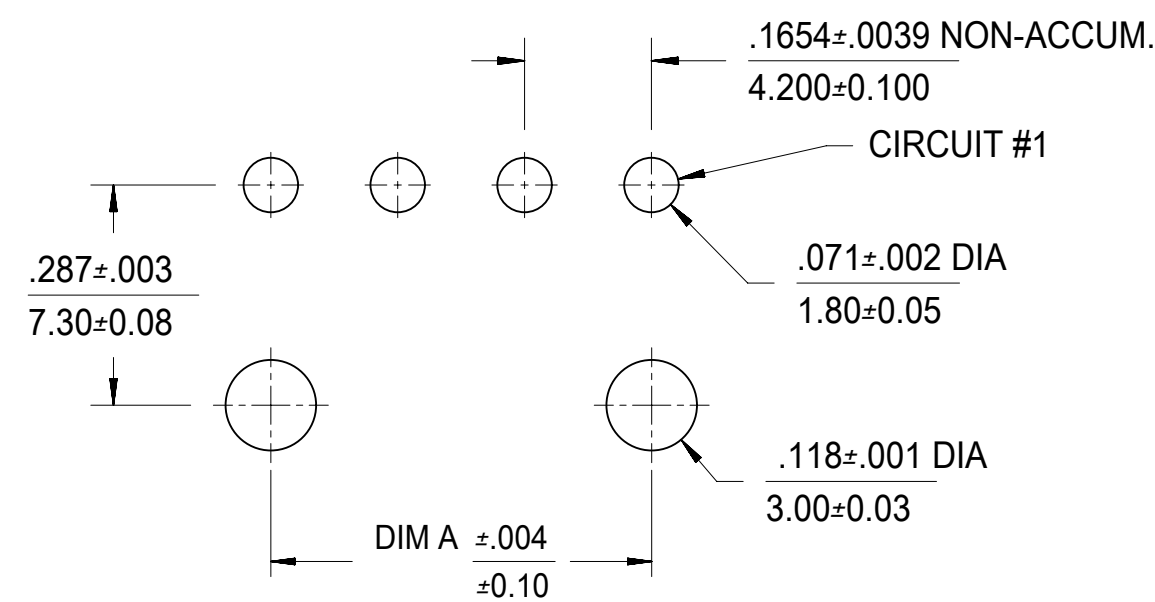

RECOMMENDED HOLE LAYOUT FOR .070/ 1.78 MAX. THICK P.C. BOARD
VIEWED FROM COMPONENT SIDE
4-12 CIRCUIT PART

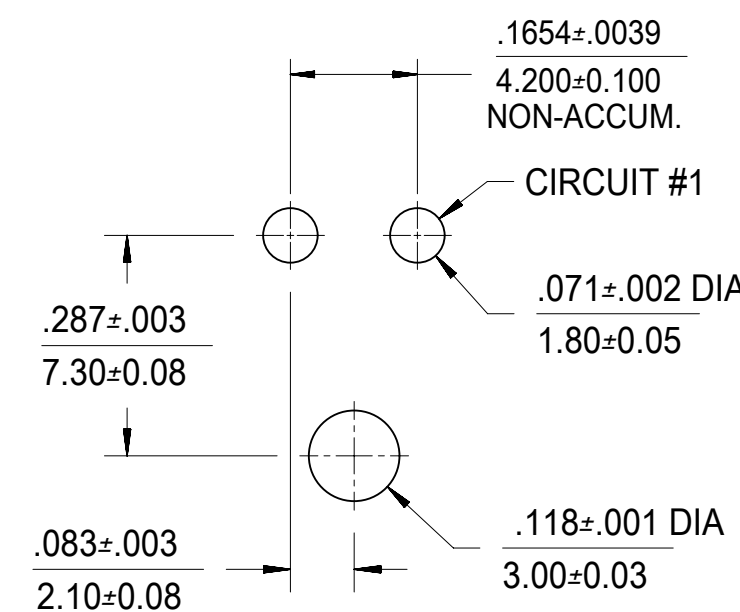

RECOMMENDED HOLE LAYOUT FOR .070/ 1.78 MAX. THICK P.C. BOARD
VIEWED FROM COMPONENT SIDE
2 CIRCUIT PART

SYMBOLS										THIS DRAWING CONTAINS INFORMATION THAT IS PROPRIETARY TO MOLEX ELECTRONIC TECHNOLOGIES, LLC AND SHOULD NOT BE USED WITHOUT WRITTEN PERMISSION									
DIMENSION UNITS		SCALE		CURRENT REV DESC: MIGRATE TO ECTR															
∇ = 0	IN/MM	4:1		EC NO: 172489 DRWN: ANESSER 2018/01/26 CHK'D: JBELL 2018/02/20 APPR: FSMITH 2018/02/22 INITIAL REVISION: DRWN: NGYEN 2015/02/05 APPR: FSMITH 2015/02/09															
∇ = 0	GENERAL TOLERANCES (UNLESS SPECIFIED)																		
∇ = 0		MM	INCH																
∇ = 0	4 PLACES	±	±																
∇ = 0	3 PLACES	±	± 0.015																
∇ = 0	2 PLACES	± 0.38	±																
∇ = 0	1 PLACE	±	±																
∇ = 0	0 PLACES	±	±																
∇ = 0	ANGULAR TOL	± 3.0 °																	
∇ = 0	DRAFT WHERE APPLICABLE MUST REMAIN WITHIN DIMENSIONS				THIRD ANGLE PROJECTION		DRAWING		SERIES		MATERIAL NUMBER		CUSTOMER		SHEET NUMBER				
∇ = 0					C-SIZE		5569		SEE CHART		GENERAL MARKET		1 OF 2						

molex

RIGHT ANGLE HEADER ASSY
MINI-FIT JR.(SINGLE ROW) (LCP)

PRODUCT CUSTOMER DRAWING

DOCUMENT NUMBER	DOC TYPE	DOC PART	REVISION
55690008-SD	PSD	000	A

EDP NO.	TOOLING STATUS	ENG. NO.	CKT. SIZE	MOUNTING OPTION	LOCK OPTION	PLATING (SEE NOTE 3)	MAT'L. (SEE NOTE 1)
46999-0699	TOOLED	5569-02A8MS-130	2	PEGS	POSITIVE	TIN/NICKEL	94V-0
46999-0701	TOOLED	5569-04A8MS-130	4	PEGS	POSITIVE	TIN/NICKEL	94V-0
50-36-2307	TOOLED	5569-05A8MS-130	5	PEGS	POSITIVE	TIN/NICKEL	94V-0
46999-0702	TOOLED	5569-06A8MS-130	6	PEGS	POSITIVE	TIN/NICKEL	94V-0
NO EDP.	NOT TOOLED	5569-07A8MS-130	7	PEGS	POSITIVE	TIN/NICKEL	94V-0
26-01-3185	NOT TOOLED	5569-08A8MS-130	8	PEGS	POSITIVE	TIN/NICKEL	94V-0
NO EDP.	NOT TOOLED	5569-09A8MS-130	9	PEGS	POSITIVE	TIN/NICKEL	94V-0
NO EDP.	NOT TOOLED	5569-10A8MS-130	10	PEGS	POSITIVE	TIN/NICKEL	94V-0
NO EDP.	NOT TOOLED	5569-11A8MS-130	11	PEGS	POSITIVE	TIN/NICKEL	94V-0
NO EDP.	NOT TOOLED	5569-12A8MS-130	12	PEGS	POSITIVE	TIN/NICKEL	94V-0

SYMBOLS	THIS DRAWING CONTAINS INFORMATION THAT IS PROPRIETARY TO MOLEX ELECTRONIC TECHNOLOGIES, LLC AND SHOULD NOT BE USED WITHOUT WRITTEN PERMISSION													
	DIMENSION UNITS		SCALE		CURRENT REV DESC: MIGRATE TO ECTR									
	IN/MM		1:1		molex RIGHT ANGLE HEADER ASSY MINI-FIT JR.(SINGLE ROW) (LCP) PRODUCT CUSTOMER DRAWING									
	GENERAL TOLERANCES (UNLESS SPECIFIED)										EC NO: 172489		2018/01/26	
	4 PLACES ±		±								DRWN: ANESSER		2018/02/20	
	3 PLACES ±		± 0.015		CHK'D: JBELL		2018/02/20							
	2 PLACES ±		± 0.38		APPR: FSMITH		2018/02/22							
	1 PLACE ±		±		INITIAL REVISION:				DOCUMENT NUMBER					
	0 PLACES ±		±		DRWN: NGYEN		2015/02/05		55690008-SD					
	ANGULAR TOL ± 3.0 °		±		APPR: FSMITH		2015/02/09		PSD	000	A			
DRAFT WHERE APPLICABLE MUST REMAIN WITHIN DIMENSIONS				THIRD ANGLE PROJECTION		DRAWING	SERIES	MATERIAL NUMBER		CUSTOMER	SHEET NUMBER			
						C-SIZE	5569	SEE CHART		GENERAL MARKET	2 OF 2			

DOCUMENT STATUS	P1	RELEASE DATE	2018/02/22	21:31:15
-----------------	----	--------------	------------	----------

THIS DRAWING REPLACES DRAWING SD-5569-NL*-130

12	11	10	9	8	7	6	5	4	3	2	1
----	----	----	---	---	---	---	---	---	---	---	---