

### Absolute maximum ratings

( $T_a=25^\circ\text{C}$ )

Symbol	Ratings	Unit
$V_{DSS}$	60	V
$V_{GSS}$	$\pm 20$	V
$I_D$	7	A
$I_D(\text{pulse})$	15 ( $PW \leq 100\mu\text{s}$ , $D_u \leq 1\%$ )	A
$E_{AS}^*$	60	mJ
$I_{AS}$	7	A
$P_T$	4.8 ( $T_a=25^\circ\text{C}$ , with all circuits operating, without heatsink)	W
	35 ( $T_c=25^\circ\text{C}$ , with all circuits operating, with infinite heatsink)	
$\theta_{j-a}$	26 (Junction-Air, $T_a=25^\circ\text{C}$ , with all circuits operating)	$^\circ\text{C/W}$
$\theta_{j-c}$	3.57 (Junction-Case, $T_c=25^\circ\text{C}$ , with all circuits operating)	$^\circ\text{C/W}$
$V_{ISO}$	1000 (Between fin and lead pin, AC)	V <sub>rms</sub>
$T_{ch}$	150	$^\circ\text{C}$
$T_{stg}$	-40 to +150	$^\circ\text{C}$

\* :  $V_{DD}=20\text{V}$ ,  $L=20\text{mH}$ ,  $I_D=2\text{A}$ , unclamped,  $R_G=50\Omega$ , see Fig. E on page 15.

### Equivalent circuit diagram

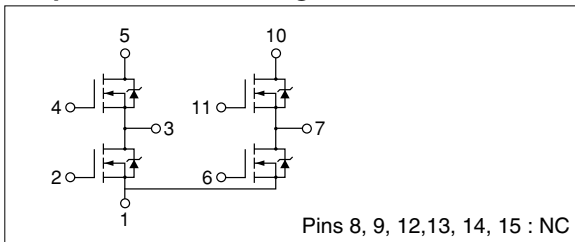

### Electrical characteristics

( $T_a=25^\circ\text{C}$ )

Symbol	Specification			Unit	Conditions
	min	typ	max		
$V_{(BR)DSS}$	60			V	$I_D=100\mu\text{A}$ , $V_{GS}=0\text{V}$
$I_{GSS}$			$\pm 100$	nA	$V_{GS}=\pm 20\text{V}$
$I_{DSS}$			100	$\mu\text{A}$	$V_{DS}=60\text{V}$ , $V_{GS}=0\text{V}$
$V_{TH}$	1.0		2.0	V	$V_{DS}=10\text{V}$ , $I_D=250\mu\text{A}$
$R_{e(yfs)}$	6			S	$V_{DS}=10\text{V}$ , $I_D=3.5\text{A}$
$R_{DS(ON)}$			0.1	$\Omega$	$V_{GS}=10\text{V}$ , $I_D=3.5\text{A}$
$C_{iss}$		660		pF	$V_{DS}=10\text{V}$ , $f=1.0\text{MHz}$ , $V_{GS}=0\text{V}$
$C_{oss}$		310		pF	
$C_{rss}$		75		pF	
$t_{d(on)}$		30		ns	$I_D=3.5\text{A}$ , $V_{DD} \approx 20\text{V}$ , $R_L=5.7\Omega$ , $V_{GS}=5\text{V}$ , see Fig. 3 on page 16.
$t_r$		90		ns	
$t_{d(off)}$		140		ns	
$t_f$		65		ns	
$V_{SD}$		1.1		V	
$t_{rr}$		80		ns	$I_{SD}=3.5\text{A}$ , $di/dt=100\text{A}/\mu\text{s}$

**$I_D$ - $V_{DS}$  Characteristics (Typical)**

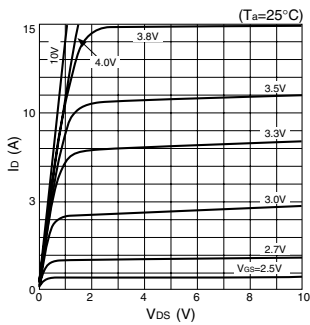

**$I_D$ - $V_{GS}$  Characteristics (Typical)**

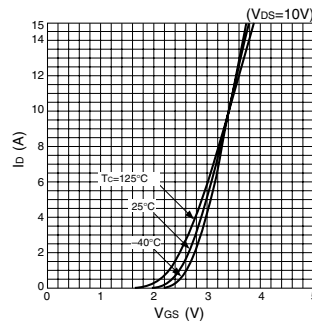

**$R_{DS(ON)}$ - $I_D$  Characteristics (Typical)**

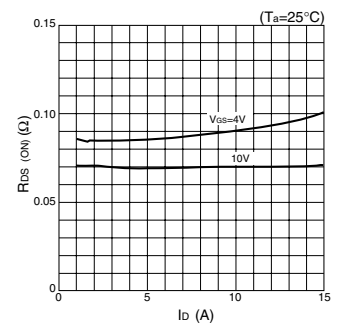

**$R_{e(yfs)}$ - $I_D$  Characteristics (Typical)**

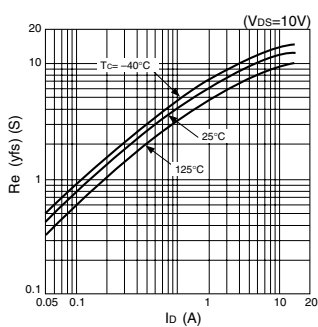

**$R_{DS(ON)}$ - $T_c$  Characteristics (Typical)**

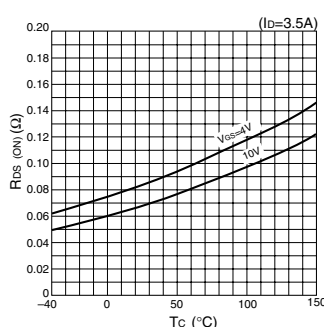

**Capacitance- $V_{DS}$  Characteristics (Typical)**

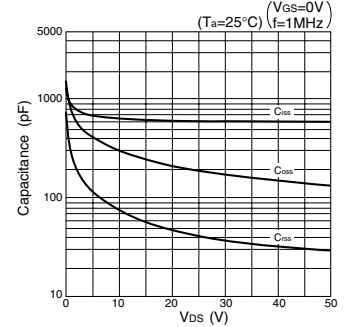

**$I_{DR}$ - $V_{SD}$  Characteristics (Typical)**

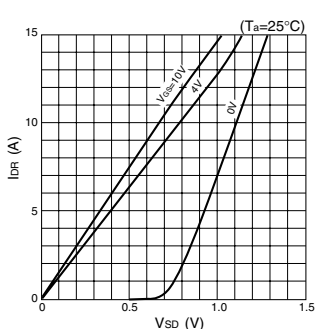

**Safe Operating Area (SOA)**

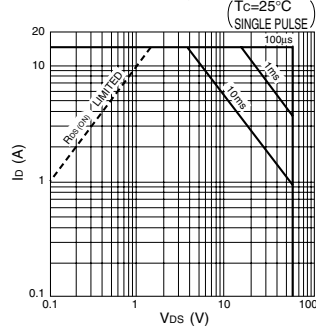

**$P_T$ - $T_a$  Characteristics**

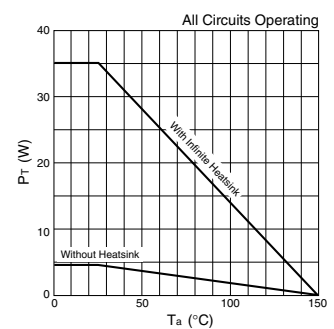

• SIP 8 (STA8Pin)

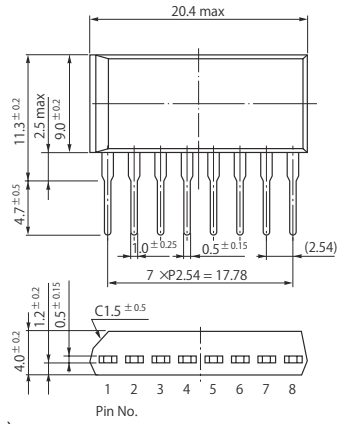

• SIP 10 (STA10Pin)

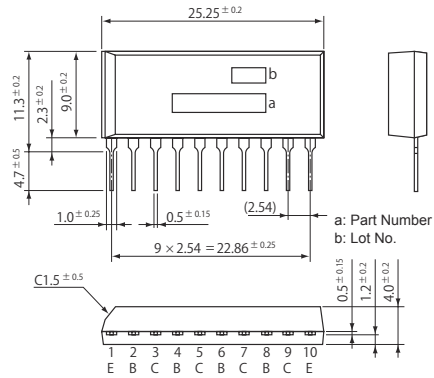

• SIP 12 (SMA12Pin)

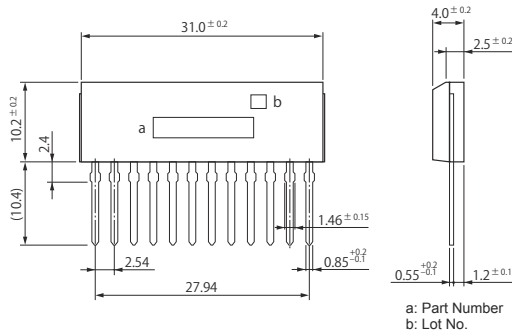

• SIP 15 (SMA15Pin)

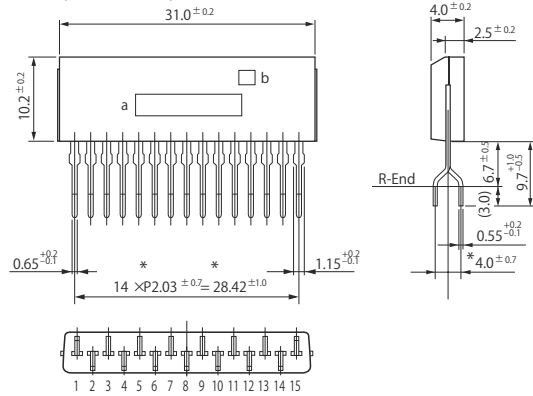

• SIP 12 with Fin (SLA12Pin)

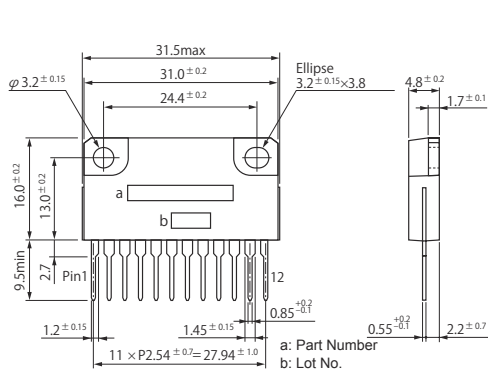

• SIP 15 with Fin (SLA15Pin)

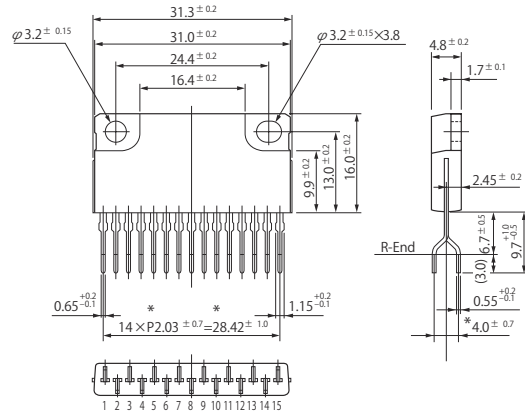

• SIP 21 with Fin (SLA21Pin)

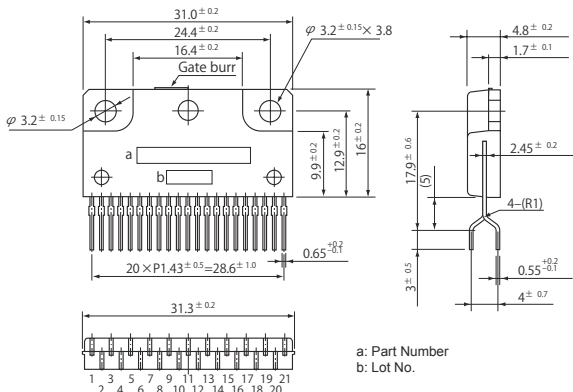

(Unit:mm)