

TW3801

Security Link Over Coax (SLOC) Transmitter

FN8283

Rev.1.00

November 29, 2012

SLOC™ (Security Link Over Coax) is a transmission protocol for simultaneously transmitting analog CVBS video and digital IP video over a single coaxial cable.

The TW3801 is the transmitting (“camera”) end of a SLOC link, combining Ethernet digital video data and analog CVBS video into a single SLOC signal that can be transmitted over 500m of coaxial cable. It can be embedded into a camera or configured as a stand-alone IP+CVBS-to-SLOC converter.

The TW3801 includes an AFE, digital modem, and two Ethernet MII/RMII interfaces. The device accepts an analog CVBS signal and an Ethernet (R)MII signal and encodes it into a SLOC signal.

Applications

- Single-channel SLOC transmitter modem
- Embedded SLOC camera modem

Features

- Simultaneous transmission of IP video data and analog CVBS video over up to 500m of RG59 coaxial cable
- Analog CVBS video preview support
- Proprietary adaptive analog equalizer for extending the reach of CVBS video
- Proprietary SLOC-based IP DVR detection
- Creates a full-duplex 100BASE-T digital link
- 36Mbps downlink speed from TW3801 to TW3811
- 4Mbps uplink for SLOC compliance
- Ethernet MAC MII/RMII interface for interfacing to Camera ISPs
- Ethernet PHY MII/RMII interface for interfacing to Ethernet PHY chip
- I²C 2-wire control interface
- Integrated PLL with 25MHz crystal interface
- 1.8V, 3.3V supplies
- 100-TQFP (12mmx12mm) Package

Application Block Diagram

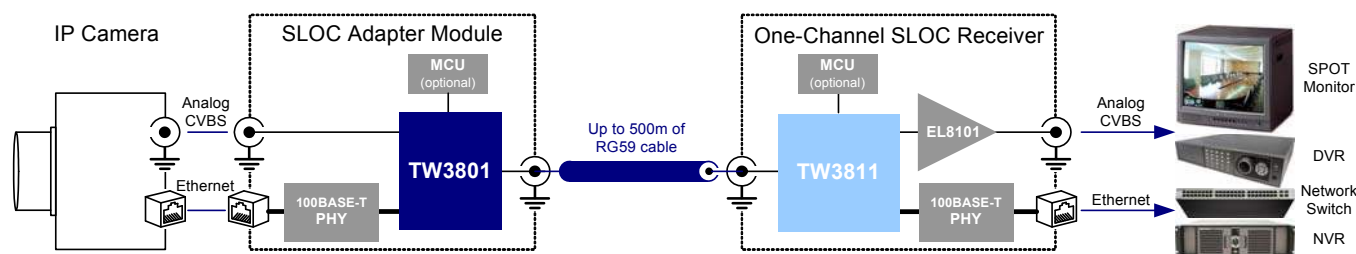

Simplified Application Schematic

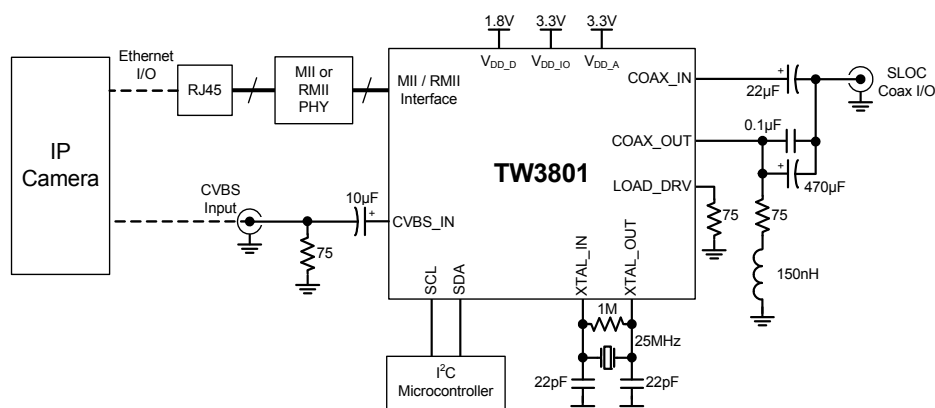

Ordering Information

PART NUMBER	PART MARKING	TEMP RANGE (°C)	PACKAGE (Pb-free)	PKG. DWG. #
TW3801-TC1-CR (Notes 1, 2, 3)	TW3801 TC1-CR	-40 to +85	100 Ld TQFP	Q100.12X12A
TW3801-TC1-CR-EVAL	Evaluation Board			

NOTES:

1. Add "T" suffix for tape and reel. Please refer to [TB347](#) for details on reel specifications.
2. These Intersil Pb-free plastic packaged products employ special Pb-free material sets, molding compounds/die attach materials, and 100% matte tin plate plus anneal (e3 termination finish, which is RoHS compliant and compatible with both SnPb and Pb-free soldering operations). Intersil Pb-free products are MSL classified at Pb-free peak reflow temperatures that meet or exceed the Pb-free requirements of IPC/JEDEC J STD-020.
3. For more information on MSL please see tech brief [TB363](#).

Pin Configuration

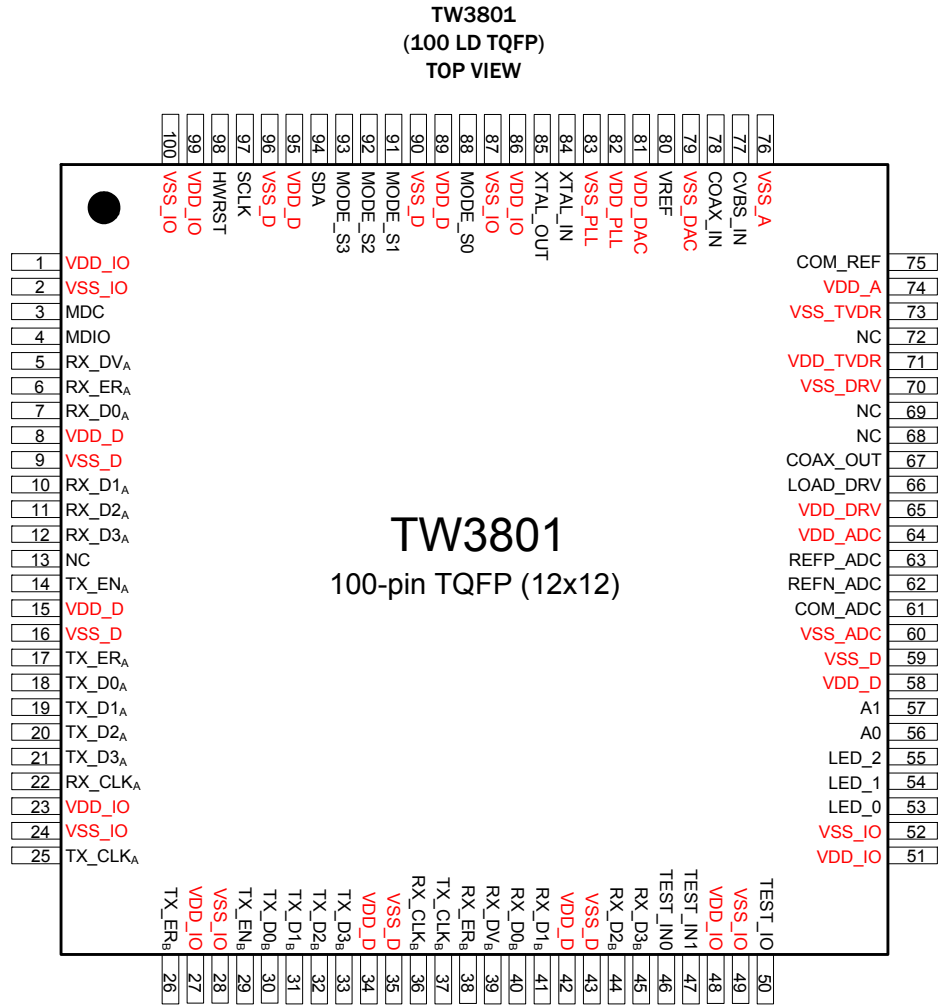

Pin Descriptions

SYMBOL	NUMBER	DESCRIPTION
POWER SUPPLY AND GROUND		
VDD_IO	1, 23, 27, 48, 51, 86, 99	3.3V Power supply for all digital I/Os. Connect to the 3.3V supply through a MI0805K601R-10 (or equivalent) ferrite bead and bypass each supply pin to ground plane with a 0.1 μ F capacitor.
VSS_IO	2, 24, 28, 49, 52, 87, 100	Digital I/O Ground. Connect each pin to ground plane using the shortest/lowest inductance path possible.
VDD_D	8, 15, 34, 42, 58, 89, 95	1.8V Power supply for core digital logic. Connect to the 1.8V supply through a MI0805K601R-10 (or equivalent) ferrite bead and bypass each supply pin to ground plane with a 0.1 μ F capacitor.
VSS_D	9, 16, 35, 43, 59, 90, 96	Digital Core Ground. Connect each pin to ground plane using the shortest/lowest inductance path possible.
VDD_ADC	64	3.3V Power supply for internal ADC. Connect to the 3.3V supply through a MI0805K601R-10 (or equivalent) ferrite bead and bypass to ground plane with a 0.1 μ F capacitor.
VSS_ADC	60	ADC Analog Ground. Connect to ground plane using the shortest/lowest inductance path possible.
VDD_DRV	65	3.3V Power supply for analog output stages. Connect to the 3.3V supply through a MI0805K601R-10 (or equivalent) ferrite bead and bypass to ground plane with a 0.1 μ F capacitor.
VSS_DRV	70	Analog Output Driver Ground. Connect to ground plane using the shortest/lowest inductance path possible.
VDD_A	71, 74	3.3V Power supply for internal analog. Connect to the 3.3V supply through a MI0805K601R-10 (or equivalent) ferrite bead and bypass each pin to ground plane with a 0.1 μ F capacitor.
VSS_A	73, 76	Analog Ground. Connect each pin to ground plane using the shortest/lowest inductance path possible.
VDD_DAC	81	3.3V Power supply for DAC. Connect to the 3.3V supply through a MI0805K601R-10 (or equivalent) ferrite bead and bypass to ground plane with a 0.1 μ F capacitor.
VSS_DAC	79	DAC Analog Ground. Connect to ground plane using the shortest/lowest inductance path possible.
VDD_PLL	82	3.3V Power supply for PLL. Connect to the 3.3V supply through a MI0805K601R-10 (or equivalent) ferrite bead and bypass to ground plane with a 0.1 μ F capacitor.
VSS_PLL	83	PLL Analog Ground. Connect to ground plane using the shortest/lowest inductance path possible.
ANALOG		
ADC_COM	61	Analog Output. Internally Generated ADC Reference Voltage. Common mode reference voltage for ADC. Bypass to ground plane with a 0.1 μ F capacitor.
ADC_REFN	62	Analog Output. Internally Generated ADC Reference Voltage. Negative differential reference voltage for ADC. Bypass to ground plane with a 0.1 μ F capacitor.
ADC_REFP	63	Analog Output. Internally Generated ADC Reference Voltage. Positive differential reference voltage for ADC. Bypass to ground plane with a 0.1 μ F capacitor.
LOAD_DRV	66	Analog Output. Driver Reference Load. The signal on this pin generates the output current that is mirrored onto the COAX_OUT pin. Connect to a 75 Ω , 1% resistor to ground. To maximize stability, ensure that this signal is isolated from the COAX_OUT signal. This can be achieved by placing the resistor on the bottom side of PCB and routing the trace in the opposite direction from the COAX_OUT trace.
COAX_OUT	67	Analog Output. Coaxial TX Output. This pin is a high impedance current source output. Terminate to VSS_A with a 75 Ω 1% resistor in series with a 150nH inductor. AC-couple per Figure 1 to SLOC I/O connector.
COM_REF	75	Analog Output. Internally Generated Reference Voltage. Bypass to ground plane with a 0.1 μ F capacitor.
CVBS_IN	77	Analog Input. Standard 1V _{pp} CVBS video signal from camera or other source.
COAX_IN	78	Analog Input. Coaxial RX Input.
VREF	80	Analog Input. Externally Generated Reference Voltage. Voltage reference input for internal DAC. Connect to a 1.2VDC source. This voltage can be generated from AVD_DAC with a 6.34k/3.65k resistor divider and 0.1 μ F bypass capacitor. Refer to reference schematic for more details.

Pin Descriptions (Continued)

SYMBOL	NUMBER	DESCRIPTION
XTAL_IN	84	Analog Input. Crystal Input. Connect to one end of a 25MHz crystal with 22pF capacitor and 1MΩ feedback resistor. Refer to reference schematic for more details.
XTAL_OUT	85	Analog Output. Crystal Output. Connect to other end of a 25MHz crystal with 22pF capacitor and 1MΩ feedback resistor. Refer to reference schematic for more details.
MII/RMII DIGITAL INTERFACE		
MDC	3	Digital Output. MDC is the management data clock reference for the serial management interface. The maximum frequency supported is 3.125MHz.
MDIO	4	Digital I/O. MDIO is the management data. MDIO transfers data synchronously with MDC.
The following pins are used to connect TW3801 to an external Ethernet PHY using the A Interface pins, when MODE_S3 = 0.		
RX_DV _A	5	Digital Input with internal 57k pull-down resistor to VSS_IO. Receive Data Valid. 0: The incoming data on the RX_Dn _A is not ready to be latched. 1: The incoming data on the RX_Dn _A pins is valid and should be latched using RX_CLK _A .
RX_ER _A	6	Digital Input with internal 57k pull-down resistor to VSS_IO. Receive Error. 0: The incoming data on the RX_Dn _A pins is valid. 1: The incoming data on the RX_Dn _A pins has an error.
RX_D0 _A	7	Digital Input with internal 57k pull-down resistor to VSS_IO. Receive Data bit 0.
RX_D1 _A	10	Digital Input with internal 57k pull-down resistor to VSS_IO. Receive Data bit 1.
RX_D2 _A	11	Digital Input with internal 57k pull-down resistor to VSS_IO. Receive Data bit 2. (MII mode only)
RX_D3 _A	12	Digital Input with internal 57k pull-down resistor to VSS_IO. Receive Data bit 3. (MII mode only)
TX_EN _A	14	Digital Output. Transmit Enable. 0: Data on the TX_Dn _A pins is not ready. 1: Data on the TX_Dn _A pins is valid and should be latched using TX_CLK _A .
TX_ER _A	17	Digital Output. Transmit Error This pin is normally low. When in "Passthrough Mode", this pin duplicates the state of TX_ER _B .
TX_D0 _A	18	Digital Output. Transmit Data bit 0.
TX_D1 _A	19	Digital Output. Transmit Data bit 1.
TX_D2 _A	20	Digital Output. Transmit Data bit 2. (MII mode only)
TX_D3 _A	21	Digital Output. Transmit Data bit 3. (MII mode only)
RX_CLK _A	22	Digital Input with internal 57kΩ pull-down resistor to VSS_IO. Receive Data Clock signal.
TX_CLK _A	25	Digital Input with internal 57kΩ pull-down resistor to VSS_IO. Transmit Data Clock signal. MII: 25MHz. RMII: 50MHz.
The following pins are used to connect TW3801 to an external MAC/SoC using the B Interface pins, when MODE_S3 = 1.		
TX_ER _B	26	Digital Input with internal 57kΩ pull-down resistor to VSS_IO. Receive Error. This bit is synchronous to TX_CLK _B . 0: The incoming data on the TX_Dn _B pins is valid. 1: The incoming data on the TX_Dn _B pins has an error.
TX_EN _B	29	Digital Input with internal 57kΩ pull-down resistor to VSS_IO. Transmit Enable. 0: Data on the TX_Dn _B pins is not ready. 1: Data on the TX_Dn _B pins is valid and should be latched using TX_CLK _B .
TX_D0 _B	30	Digital Input with internal 57kΩ pull-down resistor to VSS_IO. Transmit Data bit 0.
TX_D1 _B	31	Digital Input with internal 57kΩ pull-down resistor to VSS_IO. Transmit Data bit 1.
TX_D2 _B	32	Digital Input with internal 57kΩ pull-down resistor to VSS_IO. Transmit Data bit 2. (MII mode only)
TX_D3 _B	33	Digital Input with internal 57kΩ pull-down resistor to VSS_IO. Transmit Data bit 3. (MII mode only)
RX_CLK _B	36	Digital Output. Receive Data Clock signal.
TX_CLK _B	37	Digital Output. Transmit Data Clock signal.
RX_ER _B	38	Digital Output. Receiver Error. This pin is normally low. When in "Passthrough Mode", this pin duplicates the state of RX_ER _A .

Pin Descriptions (Continued)

SYMBOL	NUMBER	DESCRIPTION
RX_DV _B	39	Digital Output. Receive Data Valid. 0: The data on the RX_Dn _B is not ready to be latched. 1: The data on the RX_Dn _B pins is valid and should be latched using RX_CLK _B .
RX_D0 _B	40	Digital Output. Receive Data bit 0.
RX_D1 _B	41	Digital Output. Receive Data bit 1.
RX_D2 _B	44	Digital Output. Receive Data bit 2. (MII mode only)
RX_D3 _B	45	Digital Output. Receive Data bit 3. (MII mode only)
MISCELLANEOUS		
MODE_S0	88	Digital Inputs. TW3801 Transmission Speed Selection. Status latched at power-on/reset. Only valid if register 0x01[0] = 0. If register 0x01[0] = 1, Transmission Speed is set by register 0x0A.
MODE_S1	91	MODE_S1 = 0, MODE_S0 = 0: 36Mbps MODE_S1 = 0, MODE_S0 = 1: 28Mbps MODE_S1 = 1, MODE_S0 = 0: 25Mbps MODE_S1 = 1, MODE_S0 = 1: 21Mbps Note: This bitrate should always be set to 36Mbps for maximum compatibility with all cameras. A lower bitrate will increase the chances of a buffer overflow without significantly increasing cable connection distance
MODE_S2	92	Digital Input. Tie to GND.
MODE_S3	93	Digital Input. MII Interface Selection. Status latched on reset/power-on. Only valid if register 0x01[0] = 0. If register 0x01[0] = 1, Interface Mode is set by register 0x01. 0: Ethernet PHY connect with SLOC by MII _A data bus. 1: SOC connect with SLOC by MII _B data bus.
LED_0 / MII_Mode_ Select	53	Digital I/O with internal 57kΩ pull-up resistor to VDD_IO (active low). As an output during normal operation, a low output on LED_0 indicates the SLOC data link is connected. If register 0x01[0] = 0, the state of this pin is latched at power-on/reset to set MII or RMII operation. If register 0x01[0] = 1, MII or RMII operation is determined by register 0x01[5]. >2.0V: MII mode (default if pin is floating) <0.8V: RMII mode (10kΩ pull-down resistor or equivalent)
LED_1	54	Digital I/O with internal 57kΩ pull-up resistor to VDD_IO (active low). A low output on LED_1 indicates MII Transmit Data is valid. For correct TW3801 operation, this pin must be left floating or be held to a voltage >2.0V during power on/reset.
LED_2	55	Digital I/O with internal 57kΩ pull-up resistor to VDD_IO (active low). A low output on LED_2, indicates MII Receive Data is valid. For correct TW3801 operation, this pin must be left floating or be held to a voltage >2.0V during power on/reset.
SDA	94	Digital I/O with open-drain. I ² C Serial Data.
SCLK	97	Digital Input. I ² C Clock.
A0	56	Digital Input with internal 57kΩ pull-down resistor to VSS_IO. TW3801 I ² C Address Bit 0.
A1	57	Digital Input with internal 57kΩ pull-down resistor to VSS_IO. TW3801 I ² C Address Bit 1.
HWRST	98	Digital I/O with internal 57kΩ pull-up resistor to VDD_IO (active low). Active LOW system reset. To reset the TW3801, hold low (<0.8V) for at least 12 cycles of the 25MHz crystal clock after the oscillator has stabilized (crystal oscillator may take up to 1ms to start up and stabilize after power is applied).
TEST_IN0, TEST_IN1	46, 47	Digital Input with internal 57kΩ pull-down resistor to VSS_IO. Do not connect anything to this pin.
TEST_IO	50	Digital I/O with internal 57kΩ pull-down resistor to VDD_IO. Do not connect anything to this pin.
NC	13, 68, 69, 72, 77	Do Not Connect. Do not connect anything to these pins.

Absolute Maximum Ratings

VDD_D Digital Core Supply Voltage Range	-0.5V to 2.4V
VDD_IO Digital I/O Supply Voltage Range	-0.5V to 4.3V
VDD_A=VDD_ADC=VDD_DRV=VDD_TVDR=VDD_DAC=VDD_PLL	
Analog Supply Voltage Range	-0.5V to 4.3V
Voltage on Digital I/O Pins	-0.5V to 5.5V
Voltage on Analog I/O Pins	-0.5V to 4.3V
ESD Rating	
Human Body Model (Tested per JESD22-A114E)	2kV
Machine Model (Tested per JESD22-A115-A)	200V
CDM Model (Tested per JESD22-C101)	750V
Latch Up (Tested per JESD-78B; Class 2, Level A)	±100mA

Thermal Information

Thermal Resistance (Typical)	θ_{JA} (°C/W)	θ_{JC} (°C/W)
100 Ld TQFP Package (Notes 4, 5)	41	7
Maximum Junction Temperature (Plastic Package)	+125°C	
Storage Temperature Range	-65°C to +150°C	
Pb-Free Reflow Profile	see link below http://www.intersil.com/pbfree/Pb-FreeReflow.asp	
Pb-Free Reflow Profile (*)	see TB487 *Peak temperature during solder reflow +235°C max	

Recommended Operating Conditions

Temperature	-40°C to +85°C
VDD_D Digital Supply Voltage	1.6V to 2.0V
VDD_IO Digital Supply Voltage	3.0V to 3.6V
VDD_ADC=VDD_DRV=VDD_TVDR=VDD_A=VDD_DAC	
=VDD_PLL Analog Supply Voltage	3.0V to 3.6V

CAUTION: Do not operate at or near the maximum ratings listed for extended periods of time. Exposure to such conditions may adversely impact product reliability and result in failures not covered by warranty.

NOTES:

- θ_{JA} is measured with the component mounted on a high effective thermal conductivity test board in free air. See Tech Brief [TB379](#) for details.
- For θ_{JC} , the "case temp" location is taken at the package top center.

Electrical Specifications VDD_D = 1.8V, VDD_I/O = 3.3V, VDD_ADC = VDD_DRV = VDD_TVDR = VDD_A = VDD_DAC = VDD_PLL = 3.3V, T_A = +25°C. **Boldface limits apply over the operating temperature range, -40°C to +85°C.** (Note 6)

SYMBOL	PARAMETER	TEST CONDITIONS	MIN	TYP	MAX	UNITS
POWER SUPPLY						
VDD_D	Digital Core Supply Voltage Range		1.6	1.8	2.0	V
IDD_D	VDD_D Supply Current			160		mA
VDD_IO	Digital I/O Supply Voltage Range		3.0	3.3	3.6	V
IDD_IO	VDD_IO Supply Current			7		mA
VDD_A	Analog Supply Voltage Range		3.0	3.3	3.6	V
IDD_A	VDD_A Supply Current			135		mA
PD	Total Power Dissipation			760		mW
COAX I/O						
	COAX_IN Input Capacitance			9		pF
VCXO	COAX_OUT Output Level	RL = 37.5Ω, 15 - 24MHz, transmitting IP Data and CVBS		0.5		V _{P-P}
	Return Loss	RL = 75Ω, 6 - 42MHz		-10		dB
CVBS OUTPUT						
Vin	Video Input Range	100IRE White Pattern; AC-coupled to CVBS_IN		1	1.2	V _{pp}
	Luminance Non-Linearity	1M COAX, IP data on, VIN = TW3801 CVBS_IN, 5 step pattern, VOUT = TW3811 CVBS_OUT		5		%
	Chroma Non-Linear Gain Distortion (reference for 40IRE)	1M COAX, IP data on, VIN = TW3801 CVBS_IN, Modulated pedestal signal, VOUT = TW3811 CVBS_OUT		-1.8		%
	Chroma Non-Linear Phase Distortion (Reference for 40IRE)	1M COAX, IP data on, VIN = TW3801 CVBS_IN, Modulated pedestal signal, VOUT = TW3811 CVBS_OUT		-2		°

Electrical Specifications VDD_D = 1.8V, VDD_I/O = 3.3V, VDD_ADC = VDD_DRV = VDD_TVDR = VDD_A = VDD_DAC = VDD_PLL = 3.3V, T_A = +25 °C. **Boldface limits apply over the operating temperature range, -40 °C to +85 °C.** (Note 6) **(Continued)**

SYMBOL	PARAMETER	TEST CONDITIONS	MIN	TYP	MAX	UNITS
DG	Differential Gain	1M COAX, IP data on, VIN = TW3801 CVBS_IN, Modulated ramp, VOUT = TW3811 CVBS_OUT		4		%
DP	Differential Phase	1M COAX, IP data on, VIN = TW3801 CVBS_IN, Modulated ramp, VOUT = TW3811 CVBS_OUT		-0.6		°
BW	Video Bandwidth (-3dB)	1M COAX, IP data on, VIN = TW3801 CVBS_IN, VOUT = TW3811 CVBS_OUT		5.4		MHz
SNR	Video Signal-To-Noise Ratio	1M COAX, IP data on, Unweighted filter, VIN = TW3801, 100IRE White pattern, VOUT = TW3811 CVBS_OUT		52.5		dB
DIGITAL I/O						
DIGITAL INPUTS						
VIH	Input High Voltage (TTL)		2.0		5.5	V
VIL	Input Low Voltage (TTL)		-0.3		0.8	V
IL	Input Leakage Current (Inputs Without Pull-up Or Pull-down Resistors)	VIN = 3.3V and 0V			±10	μA
CIN	Input Capacitance			6		pF
DIGITAL OUTPUTS						
VOH	Output High Voltage		2.4			V
VOL	Output Low Voltage				0.4	V
EXTERNAL CRYSTAL/REFERENCE CLOCK REQUIREMENTS (per MII/RMII standard)						
f _{XTAL}	External Crystal/Clock Frequency			25		MHz
XTALTOL	External Crystal/Clock Tolerance				±50	ppm

NOTES:

6. Compliance to datasheet limits is assured by one or more methods: production test, characterization and/or design.

Register Listing

ADDRESS	REGISTER (DEFAULT VALUE)	BIT(S)	FUNCTION NAME	DESCRIPTION
0x00	Reset and Device ID (0x80)	0	Soft Reset	Soft chip reset. Write a 1 to reset. Will set itself to 0 when reset is complete. Does not reset register settings.
		4:1	Reserved	Set to 0 when writing this register.
		7:5	Revision ID	100: C1 Revision
0x01	SLOC Configuration (0x60)	0	Config Source	0: Configuration determined by external pins (default). 1: Configuration determined by registers 0x01 and 0x0A.
		1	Operational Mode	0: Transmitter (TW3801) (default) 1: Receiver (TW3811)
		2	Reserved	Set to 0 when writing this register.
		4:3	I/O Configuration	00: MII _A bus enabled. TW3801 acts like a MAC and is connected to a PHY (default). 01: MII _B bus enabled. TW3801 acts like a PHY and is connected to a MAC. 02: Both MII _A and MII _B buses are connected together (passthrough mode) (experimental). 03: Reserved
		5	Interface Selection	0: RMII 1: MII (default)
		6	RMII Clock Source	0: An internally-generated 50MHz RMII reference clock is available on the TEST_IO pin. 1: An externally-supplied 50MHz RMII reference clock must be supplied to TX_CLK _A pin for RMII operation (default).
		7	Reserved	Set to 0 when writing this register.
0x0A	Transmit Link Datarate (0x00)	4:0	Tx Link Datarate	When 0x01[0] = 0, the transmit datarate is determined by the MODE_S0 and MODE_S1 pins. When 0x01[0]=1, this register sets the bitrate of data transmitted from the TW3801 to the TW3811. This bitrate should always be set to 36Mbps for maximum compatibility with all cameras. A lower bitrate will increase the chances of a buffer overflow without significantly increasing cable connection distance. The speed selection choices below are shown for historical continuity. Use 0x13 for all new designs. 0x0C: 25Mbps 0x0A: 21Mbps 0x11: 28Mbps 0x13: 36Mbps 0x00 - 0x0B, 0x10, 0x12, 0x14-0x1F: Reserved
		7:5	Reserved	Set to 0 when writing this register.
0x14	Receive Link Datarate (Read Only)	4:0	Rx Link Datarate	When a SLOC link is established, this register indicates the bit rate of the data from the TW3811 to the TW3801. 0x02: 3Mbps 0x04: 4Mbps 0x11: 9Mbps 0x13: 11Mbps
		7:5	Reserved	
0x19	CVBS Channel Gain (0x00)	6:0	CVBS Gain	0x00: Minimum CVBS Gain (default) 0x7F: Maximum CVBS Gain
		7	Reserved	Set to 0 when writing this register.

Register Listing (Continued)

ADDRESS	REGISTER (DEFAULT VALUE)	BIT(S)	FUNCTION NAME	DESCRIPTION
0x1E	MDIO 1 (0x00)	0	MDIO Register Read	MDIO register read command. Specify MDIO register address in 0x1F, apply read command (set this bit), clear read command (clear this bit), then read MDIO register value in registers 0x22 and 0x23.
		1	MDIO Register Write	MDIO register write command. Specify MDIO register address in 0x1F, write MDIO register data into registers 0x20 and 0x21, apply write command (set this bit), then clear write command (clear this bit).
		3:2	Reserved	Set to 0 when writing this register.
		6:4	MDIO PHY Address	These are the 3 MSB bits of MDIO PHY address that SLOC needs to match with Ethernet-PHY chip's PHY address. The 2 lower LSB = {A1,A0}, where A1 and A0 are set by the logic levels of the external A1 and A0 pins.
		7	Reserved	Set to 0 when writing this register.
0x1F	MDIO 2 (0x00)	4:0	MDIO Register R/W Address	
		7:5	Reserved	Set to 0 when writing this register.
0x20	MDIO OUT DATA LSB (0x00)	7:0	MDIO OUT (LSB)	Lower 8 bits of 16 bit word to be transmitted.
0x21	MDIO OUT DATA MSB (0x00)	7:0	MDIO OUT (MSB)	Upper 8 bits of 16 bit word to be transmitted.
0x22	MDIO IN DATA LSB (Read Only)	7:0	MDIO IN (LSB)	Lower 8 bits of 16 bit word received.
0x23	MDIO IN DATA MSB (Read Only)	7:0	MDIO IN (MSB)	Upper 8 bits of 16 bit word received.
0x26	SLOC Control (0x00)	0	Control Overwrite	0: Automatic System Control. SLOC Tx and Rx automatically enabled if "Ethernet PHY Connected" bit is set (44[3] = 1). 1: Manual System Control. SLOC Tx and Rx enabled based on bits 3 and 4 of this register.
		2:1	Reserved	Set to 11b when writing this register.
		3	SLOC Transmitter Enable	0: Disabled. 1: Enabled.
		4	SLOC Receiver Enable	0: Disabled. 1: Enabled.
		7:5	Reserved	Set to 0 when writing this register.
0x27	Reed-Solomon Segment Monitor Count (0x00)	7:0	Reed-Solomon Segments	The number of segments to monitor error count at Reed-Solomon Decoder. Actual segment number is 65536 x [the value in this register]. After setting this register, check status bit Error Count Updated (0x43, bit[0]) for completion of error count. A value of 0 in this register will disable the Reed-Solomon Error Counter and reset Error Count Updated (0x43 bit[0]) to 0.
0x40	Reed-Solomon Error Count 7:0 (Read Only, default is 0xFF)	7:0	Error Count 7:0	Bits 7:0 of the 24-bit Reed-Solomon Error Count. Registers 0x40 - 0x42 = 0FFFFFFF whenever 0x43[0] = 0.
0x41	Reed-Solomon Error Count 15:8 (Read Only, default is 0xFF)	7:0	Error Count 15:8	Bits 15:8 of the 24-bit Reed-Solomon Error Count. Registers 0x40 - 0x42 = 0FFFFFFF whenever 0x43[0] = 0.
0x42	Reed-Solomon Error Count 23:16 (Read Only, default is 0xFF)	7:0	Error Count 23:16	Bits 23:16 of the 24-bit Reed-Solomon Error Count. Registers 0x40 - 0x42 = 0FFFFFFF whenever 0x43[0] = 0.
0x43	Reed-Solomon Error Count Updated (Read Only, default is 0x00)	0	Error Count Updated	0: Reed-Solomon Error Count is not valid. 1: Reed-Solomon Error Count value has been updated. To clear this bit, write a 0 to register 0x27.
		7:1	Reserved	

Register Listing (Continued)

ADDRESS	REGISTER (DEFAULT VALUE)	BIT(S)	FUNCTION NAME	DESCRIPTION
0x44	Status Bits (Read Only)	2:0	Reserved	
		3	Ethernet PHY Connected	0: Ethernet PHY reporting no link. 1: Ethernet PHY reporting link established.
		4	SLOC Rx Locked	0: SLOC carrier not detected. 1: SLOC carrier detected and locked.
		5	SLOC Data Active	0: SLOC data link not established. 1: SLOC data link established.
		7:6	Reserved	

Functional Description

Functional Overview

The TW3801 block diagram is shown in Figure 1.

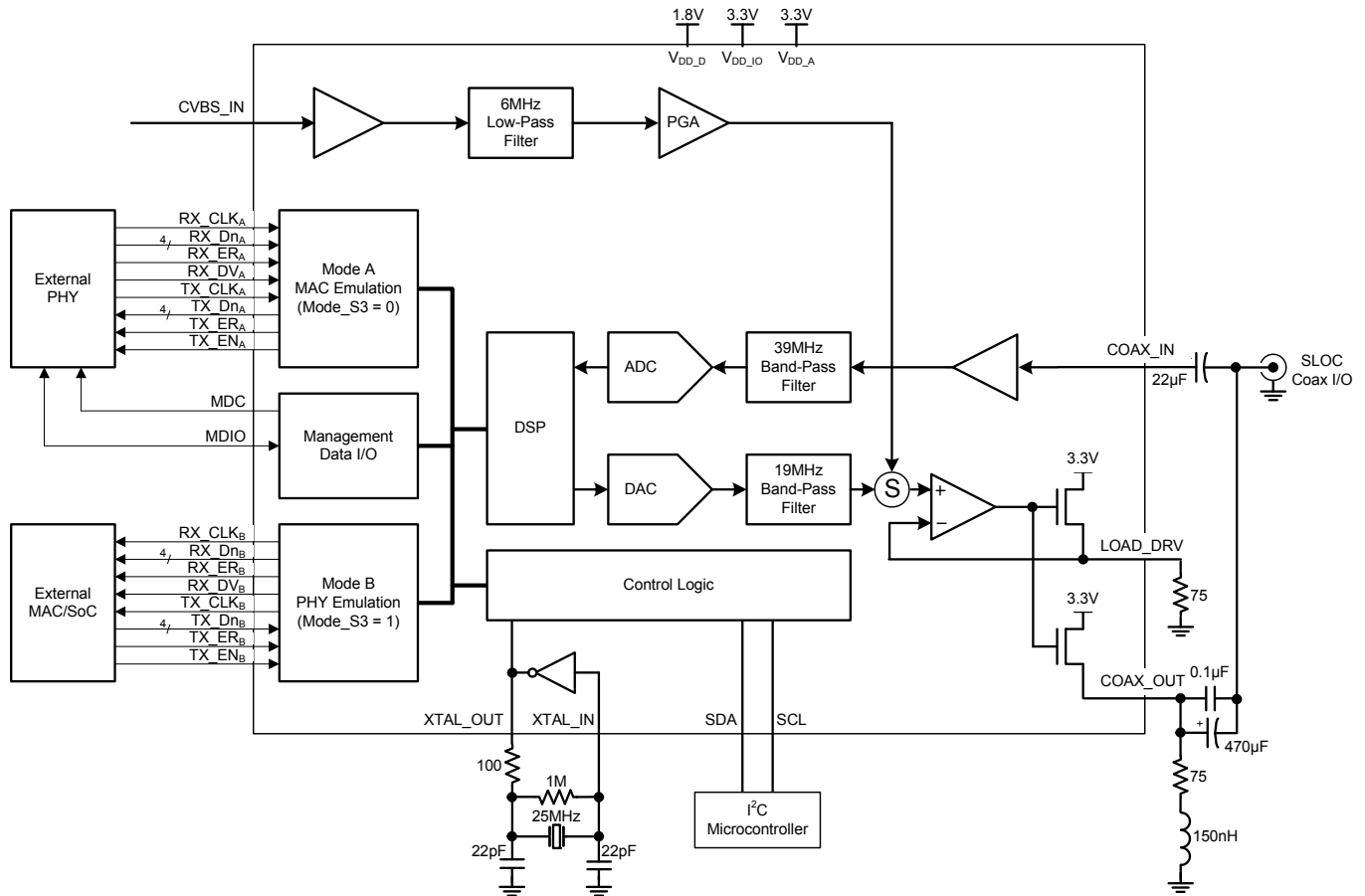

FIGURE 1. TW3801 INTERNAL BLOCK DIAGRAM

Applications Information

External Interfacing

The TW3801 uses the standard Ethernet MII or RMI interface to communicate with Ethernet PHYs (in Mode A, where the TW3801 emulates a MAC) or Ethernet MACs (in Mode B, where the TW3801 emulates a PHY).

The TW3801 supports the 100BASE-T communication mode. 10BASE-T communication is not supported, so both ends of a SLOC system must be connected to 100BASE-T devices.

Management Interface

The management interface is a serial bus used in Mode A to communicate between the TW3801 and the external PHY it is connected to.

SLOC as a MDIO master will check Ethernet PHY linkup status periodically by sending out MDC and MDIO signals. It requires SLOC to have MDIO PHY address to sync with the Ethernet-PHY chip's PHY address [4:0]. The SLOC MDIO PHY address can be programmed at {Reg0x1E[6:4], A1,A0}, where A1 and A0 are set by the logic levels of the external A1 and A0 pins.

Management Data I/O Timing

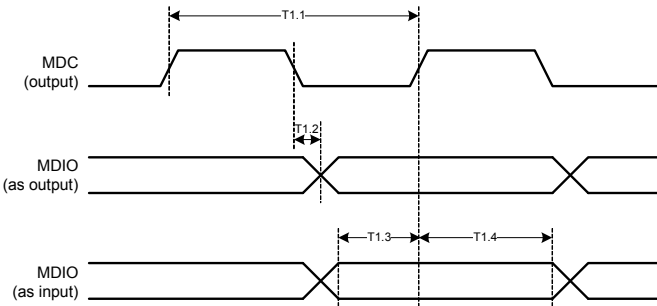

TABLE 1. MDIO INTERFACE TIMING

PARAMETER	DESCRIPTION	MIN	TYP	MAX	UNIT
T1.1	MDC Clock Cycle Time		8/f _{XTAL}		ns
DC _{MDC}	MDC Clock Duty Cycle	45		55	%
T1.2	MDIO Data Output Delay			5	ns
T1.3	MDIO Data Input Setup Time	10			ns
T1.4	MDIO Data Input Hold Time	10			ns

Setting the MDIO PHY Address

The TW3801's MDIO PHY address is abcde (in binary), where:

- a = register 0x1E bit 6
- b = register 0x1E bit 5
- c = register 0x1E bit 4
- d = state of A1 (pin 57)
- e = state of A0 (pin 56)

The TW3801's MDIO PHY address should be set to match the PHY address of the device it is connected to.

MII Interface

Ethernet data is transferred via the MII or RMI interface. The TW3801 is designed to work with any PHY with an MII interface, and has been tested with the following PHYs in MII mode:

- 88E1111 (Marvell)
- IP101A (IC+)
- LAN8710 (SMSC)
- RTL8201EL (Realtek)

MII Mode A (MAC Emulation) Input Timing

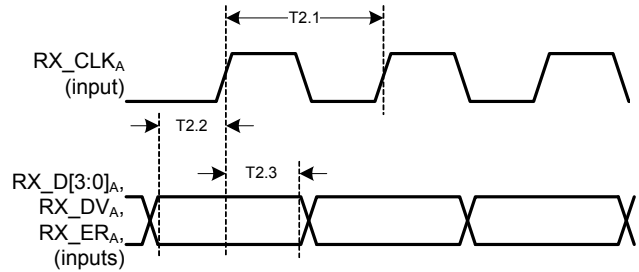

TABLE 2. MII MODE A (MAC EMULATION) INPUT TIMING

PARAMETER	DESCRIPTION	MIN	TYP	MAX	UNIT
T2.1	RX_CLK _A Period		40		ns
DC _{RX_CLKA}	RX_CLK _A Duty Cycle	20		80	%
T2.2	Data Setup Time	10			ns
T2.3	Data Hold Time	10			ns

MII Mode A (MAC Emulation) Output Timing

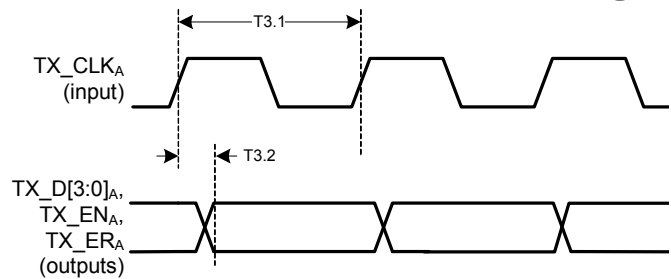

TABLE 3. MII MODE A (MAC EMULATION) OUTPUT TIMING

PARAMETER	DESCRIPTION	MIN	TYP	MAX	UNIT
T3.1	TX_CLK _A Period		40		ns
DC _{TX_CLKA}	TX_CLK _A Duty Cycle	20		80	%
T3.2	Output Data Valid Delay			14	ns

MII Mode B (PHY Emulation) Input Timing

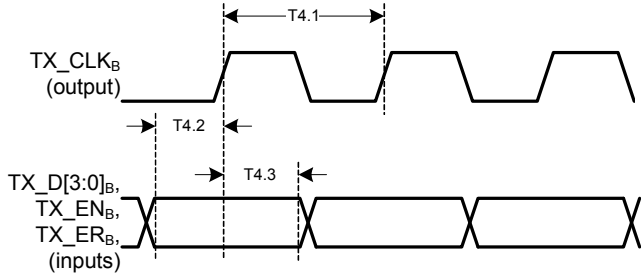

TABLE 4. MII MODE B (PHY EMULATION) INPUT TIMING

PARAMETER	DESCRIPTION	MIN	TYP	MAX	UNIT
T4.1	TX_CLK _B Period		1/f _{X_{TAL}}		ns
DC _{TX_CLKB}	TX_CLK _B Duty Cycle	45		55	%
T4.2	Data Setup Time	10			ns
T4.3	Data Hold Time	10			ns

MII Mode B (PHY Emulation) Output Timing

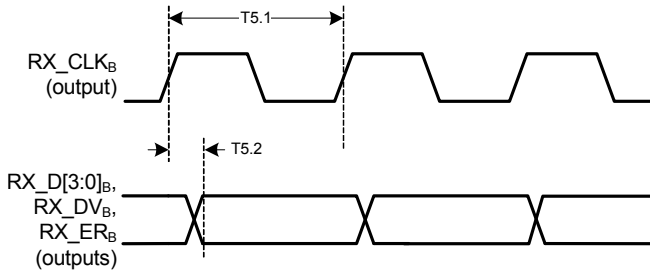

TABLE 5. MII MODE B (PHY EMULATION) OUTPUT TIMING

PARAMETER	DESCRIPTION	MIN	TYP	MAX	UNIT
T5.1	RX_CLK _B Period		1/f _{X_{TAL}}		ns
DC _{RX_CLKB}	RX_CLK _B Duty Cycle	45		55	%
T5.2	Output Data Valid Delay			5	ns

RMII Interface

Ethernet data is transferred via the MII or RMII interface. The TW3801 is designed to work with any PHY with an RMII interface, and has been tested with the IP101A (IC+) PHY in RMII mode. The 50MHz RMII clock may be supplied by the external PHY or by the TEST_IO pin (when RMII Clock Source = 1).

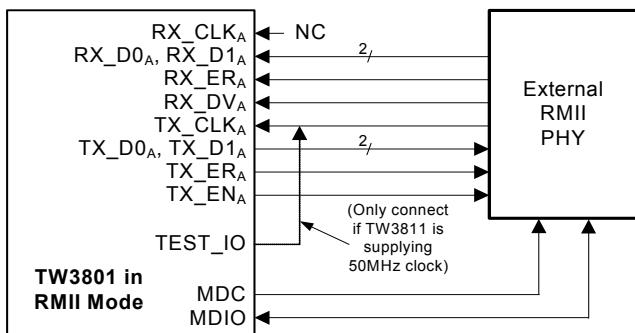

FIGURE 2. OPTIONAL USE OF TEST_IO AS RMII CLOCK SOURCE

RMII Mode A (MAC Emulation) Input Timing

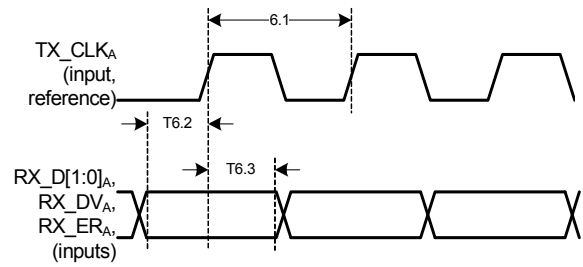

TABLE 6. RMII MODE A (MAC EMULATION) INPUT TIMING

PARAMETER	DESCRIPTION	MIN	TYP	MAX	UNIT
T6.1	TX_CLK _A Period		20		ns
DC _{TX_CLKA}	TX_CLK _A Duty Cycle	20		80	%
T6.2	Data Setup Time	4			ns
T6.3	Data Hold Time	2			ns

RMII Mode A (MAC Emulation) Output Timing

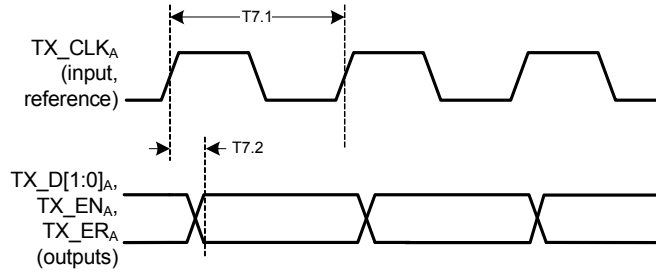

TABLE 7. RMII MODE A (MAC EMULATION) OUTPUT TIMING

PARAMETER	DESCRIPTION	MIN	TYP	MAX	UNIT
T7.1	TX_CLK _A Period		20		ns
DC _{TX_CLKA}	TX_CLK _A Duty Cycle	20		80	%
T7.2	Output Data Valid Delay			14	ns

RMII Mode B (PHY Emulation) Input Timing

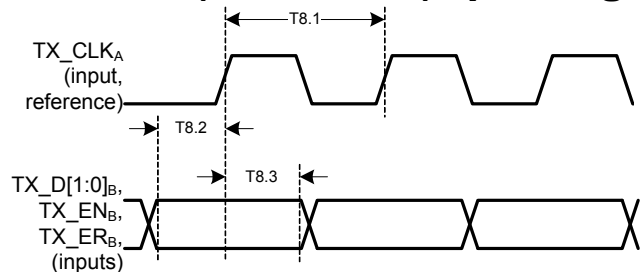

TABLE 8. RMII MODE B (PHY EMULATION) INPUT TIMING

PARAMETER	DESCRIPTION	MIN	TYP	MAX	UNIT
T8.1	TX_CLK _A Period		20		ns
DC _{TX_CLKA}	TX_CLK _A Duty Cycle	20		80	%
T8.2	Data Setup Time	4			ns
T8.3	Data Hold Time	2			ns

RMII Mode B (PHY Emulation) Output Timing

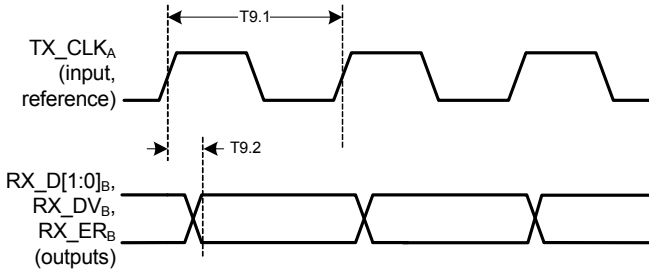

TABLE 9. RMII MODE B (PHY EMULATION) OUTPUT TIMING

PARAMETER	DESCRIPTION	MIN	TYP	MAX	UNIT
T9.1	TX_CLK _A Period		1/f _{XTAL}		ns
DC _{TX_CLKA}	TX_CLK _A Duty Cycle	45		55	%
T9.2	Output Data Valid Delay			14	ns

MII Passthrough Mode

Passthrough mode connects all the MII Inputs to all the MII outputs through the TW3801's internal drivers (Figure 3). Passthrough mode is enabled by setting Register 0x01[4:3] to 10b. Passthrough mode introduces a small delay between the input and output signals.

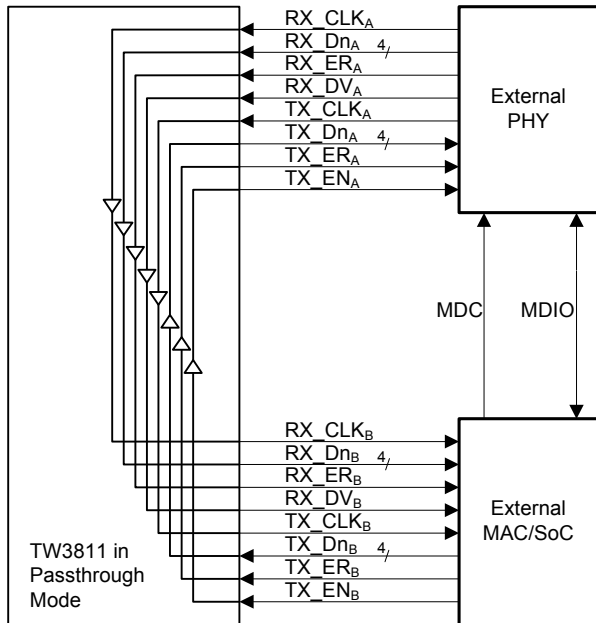

FIGURE 3. MII PASSTHROUGH MODE

TABLE 10. MII PASSTHROUGH MODE TIMING

PARAMETER	DESCRIPTION	MIN	TYP	MAX	UNIT
Signal Delay	RX_CLK _A to RX_CLK _B RX_D[3:0] _A to RX_D[3:0] _B RX_ER _A to RX_ER _B RX_DV _A to RX_DV _B TX_CLK _A to TX_CLK _B TX_D[3:0] _B to TX_D[3:0] _A TX_ER _B to TX_ER _A TX_EN _B to TX_EN _A	2.5		10	ns

RMII Passthrough Mode

In RMII Passthrough mode, the signals are registered by the TX_CLK_A clock to minimize skew (Figure 4). Passthrough mode is enabled by setting Register 0x01[4:3] to 10b. Passthrough mode introduces a small delay between the input and output signals.

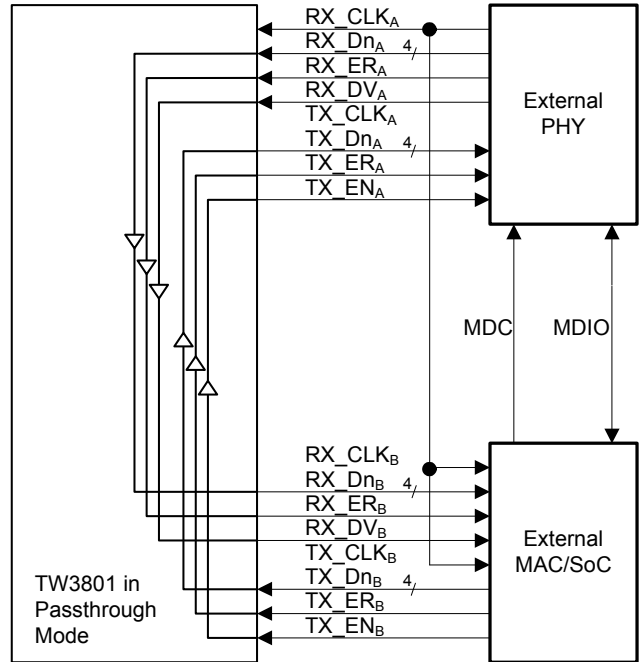

FIGURE 4. RMII PASSTHROUGH MODE

TABLE 11. RMII PASSTHROUGH MODE TIMING

PARAMETER	DESCRIPTION	MIN	TYP	MAX	UNIT
T10.1	D to Q Setup Time	4			ns
T10.2	D to Q Hold Time	2			ns

I²C Serial Interface

The TW3801 supports a bidirectional bus oriented protocol. The protocol defines any device that sends data onto the bus as a transmitter and the receiving device as the receiver. The device controlling the transfer is the master and the device being controlled is the slave. The master always initiates data transfers and provides the clock for both transmit and receive operations. Therefore, the TW3801 operates as a slave device in all applications.

All communication over the I²C interface is conducted by sending the MSB of each byte of data first.

Protocol Conventions

Data states on the SDA line can change only during SCL LOW periods. SDA state changes during SCL HIGH are reserved for indicating START and STOP conditions (see Figure 5). On power-up of the TW3801, the SDA pin is in the input mode.

All I²C interface operations must begin with a START condition, which is a HIGH to LOW transition of SDA while SCL is HIGH. The TW3801 continuously monitors the SDA and SCL lines for the START condition and does not respond to any command until this condition is met (see Figure 5). A START condition is ignored during the power-up sequence and during non-volatile write cycles for the device.

All I²C interface operations must be terminated by a STOP condition, which is a LOW to HIGH transition of SDA while SCL is HIGH (see Figure 5). A STOP condition at the end of a read operation, or at the end of a write operation places the device in its standby mode. A STOP condition at the end of a write operation to a non-volatile byte initiates an internal non-volatile write cycle. The device enters its standby state when the internal, non-volatile write cycle is completed.

An ACK, Acknowledge, is a software convention used to indicate a successful data transfer. The transmitting device, either master or slave, releases the SDA bus after transmitting eight bits. During the ninth clock cycle, the receiver pulls the SDA line LOW to acknowledge the reception of the eight bits of data (see Figure 6).

The TW3801 responds with an ACK after recognition of a START condition followed by a valid Identification Byte, and once again after successful receipt of an Address Byte. The TW3801 also responds with an ACK after receiving a Data Byte of a write operation. The master must respond with an ACK after receiving a Data Byte of a read operation.

A valid Identification Byte contains 0011 1 A1 A0 R/ \overline{W} as the seven MSBs, where A0 = the logic level of the A0 pin, A1 = the logic level of the A1 pin, and R/ \overline{W} is the bit that determines if the next operation is a read or a write. The Read/ \overline{Write} bit is "1" for a Read operation, and "0" for a Write operation (see Table 12).

Write Operation

A Write operation requires a START condition, followed by a valid Identification Byte, a valid Address Byte, a Data Byte, and a STOP condition. After each of the three bytes, the TW3801 responds with an ACK.

STOP conditions that terminate write operations must be sent by the master after sending at least 1 full data byte and its associated ACK signal. If a STOP byte is issued in the middle of a data byte, or before 1 full data byte + ACK is sent, then the TW3801 resets itself without performing the write.

TABLE 12. IDENTIFICATION BYTE FORMAT

A1	A0	ADDRESS BYTE FOR A WRITE	ADDRESS BYTE FOR A READ
0	0	0x38	0x39
0	1	0x3A	0x3B
1	0	0x3C	0x3D
1	1	0x3E	0x3F

Read Operation

A Current Address Read operation is shown in Figure 8. It consists of a minimum 2 bytes: a START followed by the ID byte from the master with the R/ \overline{W} bit set to 1, then an ACK followed by the data byte or bytes sent by the slave. The master terminates the Read operation by not responding with an ACK and then issuing a STOP condition. This operation is useful if the master knows the current address and desires to read one or more data bytes.

A Random Address Read operation consists of a three byte "dummy write" instruction followed by a Current Address Read operation (see Figure 6). The master initiates the operation issuing the following sequence: a START, the identification byte with the R/ \overline{W} bit set to "0", an Address Byte, a second START, and a second Identification byte with the R/ \overline{W} bit set to "1". After each of the three bytes, the TW3801 responds with an ACK. The TW3801 then transmits Data Bytes as long as the master responds with an ACK during the SCL cycle following the eighth bit of each byte. The master terminates the Read operation (issuing a STOP condition) following the last bit of the last Data Byte (see Figure 9).

The Data Bytes are from the registers indicated by an internal pointer. This pointer initial's value is determined by the Address Byte in the Read operation instruction, and increments by one during transmission of each Data Byte. Address 04h is the last valid data byte, higher addresses are not available. Data from addresses higher than memory location 04h will be invalid.

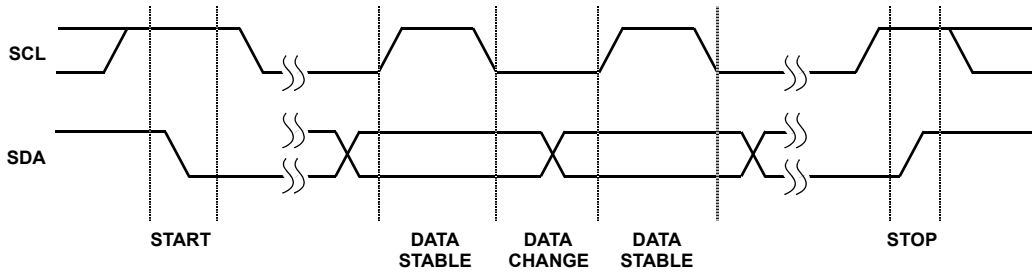

FIGURE 5. VALID DATA CHANGES, START AND STOP CONDITIONS

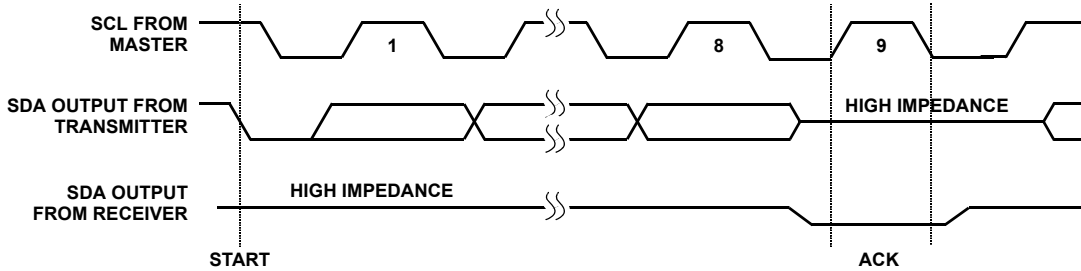

FIGURE 6. ACKNOWLEDGE RESPONSE FROM RECEIVER

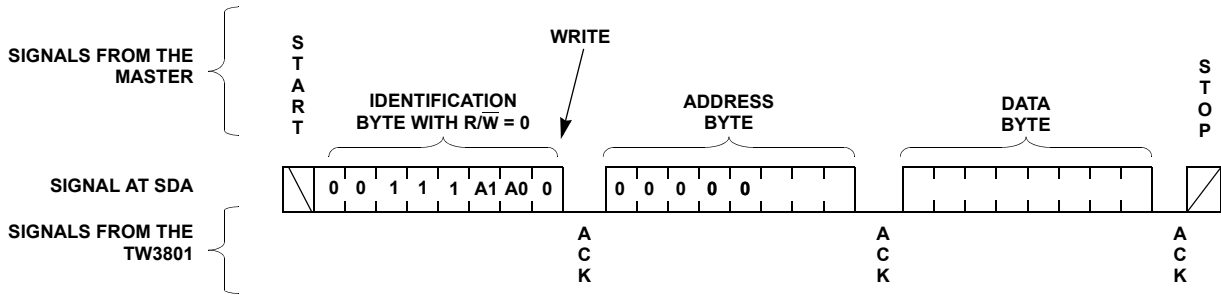

FIGURE 7. BYTE WRITE SEQUENCE

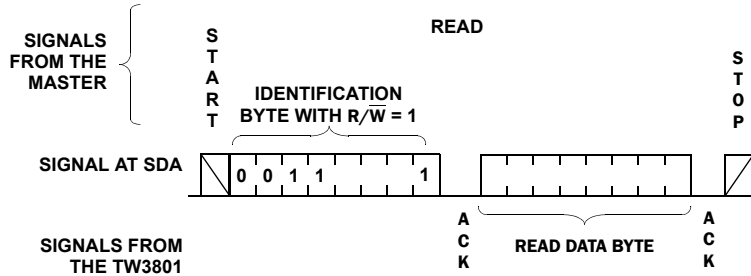

FIGURE 8. BYTE READ SEQUENCE

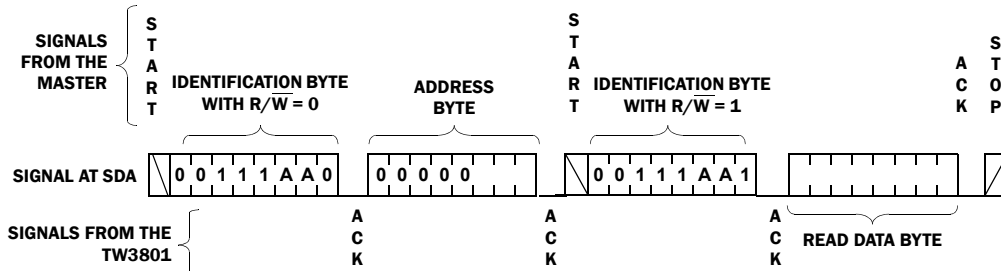

FIGURE 9. RANDOM ADDRESS READ SEQUENCE

PC Board Layout

The AC performance of this circuit depends greatly on the care taken in designing the PC board. The following are recommendations to achieve optimum high frequency performance from your PC board.

- The use of low inductance components, such as chip resistors and chip capacitors, is strongly recommended.
- Minimize signal trace lengths. Trace inductance and capacitance can easily limit circuit performance. Avoid sharp corners, use rounded corners when possible. Vias in the signal lines add inductance at high frequency and should be avoided. PCB traces greater than 1" begin to exhibit transmission line characteristics with signal rise/fall times of 1ns or less. High frequency performance may be degraded for traces greater than one inch, unless strip lines are used.
- Match channel-channel analog I/O trace lengths and layout symmetry. This will minimize propagation delay mismatches.
- Maximize use of AC de-coupled PCB layers. All signal I/O lines should be routed over continuous ground planes (i.e. no split planes or PCB gaps under these lines). Avoid vias in the signal I/O lines.
- Use proper value and location of termination resistors. Termination resistors should be as close to the device as possible.
- When testing, use good quality connectors and cables, matching cable types and keeping cable lengths to a minimum.
- Place power supply decoupling capacitors (0.1 μ F) as close to the device connections as possible. Avoid vias between the cap and the device because vias adds unwanted inductance. Larger caps can be farther away. When vias are required in a layout, they should be routed as far away from the device as possible. Do not connect anything to pins labelled "NC".

Revision History

The revision history provided is for informational purposes only and is believed to be accurate, but not warranted. Please go to web to make sure you have the latest revision.

DATE	REVISION	CHANGE
November 16, 2012	FN8283.1	<p>Changed "Application Block Diagram" on page 1 to only show 100BASE-T, and MCU as optional.</p> <p>Added 75Ω termination resistor to CVBS_IN in "Simplified Application Schematic" on page 1.</p> <p>Added 150nH inductor to COAX_OUT termination in "Simplified Application Schematic" on page 1.</p> <p>Horizontally flipped "Simplified Application Schematic" on page 1 so signal flow is from left to right.</p> <p>Eliminated unnecessary "Vdd Range" from Ordering Information table on page 2.</p> <p>For clarification, added "internal" in front of all pull-up/pull-down resistors in Pin Descriptions table.</p> <p>Added 150nH inductor to COAX_OUT pin description on page 3.</p> <p>Clarified Pin Description information for LED_0, LED_1, and LED_2 (all active low) on page 5. Previous version of datasheet incorrectly indicated LED_0 was active high.</p> <p>Changed CVBS Gain register on page 8 from 0x30 (correct for TW3811 but not TW3801) to 0x19.</p> <p>Corrected Register 0x30[6:0] on page 8 to show Maximum CVBS Gain as 0x7F.</p> <p>Changed Register 0x26 bit 7:5 on page 9 to "reserved" because the bit has no function.</p> <p>In "SLOC Control (0x00)" on page 9, changed "Set to 0 when writing this register." to "Set to 11b when writing this register."</p> <p>Clarified operation of registers 0x26, 0x27, and 0x43 on page 9.</p> <p>Added 150nH inductor to COAX_OUT termination in Figure 1 on page 11.</p> <p>Horizontally flipped Figure 1 on page 11 so signal flow is from left to right.</p> <p>Added "Setting the MDIO PHY Address" on page 12 to "Applications Information" section.</p> <p>Added "External Interfacing" paragraph to Applications Information section on page 12 clarifying that SLOC supports 100Mb/s 100BASE-T only (not 1-T).</p> <p>Added MII Interface and RMII Interface paragraphs to page 12 and page 13, including list of tested PHYs, and how to optionally use TEST_IO as the RMII clock source.</p> <p>Corrected drawings in Figures 1, 3, and 4 incorrectly showing the MDIO bus connecting the TW3811 to a MAC/SoC device.</p> <p>In "RMII Passthrough Mode" on page 14, changed "0x01[4:3] to 01b" to "0x01[4:3] to 10b"</p> <p>Emphasized 36Mbps and 4Mbps link speeds (the rates required for SLOC compliance) throughout document, including rewriting the Description section of registers 0x0A and 0x14 in the Register Listing section.</p>
June 8, 2012	FN8283.0	Initial Release

About Intersil

Intersil Corporation is a leading provider of innovative power management and precision analog solutions. The company's products address some of the largest markets within the industrial and infrastructure, mobile computing and high-end consumer markets.

For the most updated datasheet, application notes, related documentation and related parts, please see the respective product information page found at www.intersil.com.

You may report errors or suggestions for improving this datasheet by visiting www.intersil.com/ask.

Reliability reports are also available from our website at www.intersil.com/support

© Copyright Intersil Americas LLC 2012. All Rights Reserved.

All trademarks and registered trademarks are the property of their respective owners.

For additional products, see www.intersil.com/en/products.html

Intersil products are manufactured, assembled and tested utilizing ISO9001 quality systems as noted in the quality certifications found at www.intersil.com/en/support/qualandreliability.html

Intersil products are sold by description only. Intersil may modify the circuit design and/or specifications of products at any time without notice, provided that such modification does not, in Intersil's sole judgment, affect the form, fit or function of the product. Accordingly, the reader is cautioned to verify that datasheets are current before placing orders. Information furnished by Intersil is believed to be accurate and reliable. However, no responsibility is assumed by Intersil or its subsidiaries for its use; nor for any infringements of patents or other rights of third parties which may result from its use. No license is granted by implication or otherwise under any patent or patent rights of Intersil or its subsidiaries.

For information regarding Intersil Corporation and its products, see www.intersil.com

