

PROPER USE GUIDELINES

Cumulative Trauma Disorders can result from the prolonged use of manually powered hand tools. Hand tools are intended for occasional use and low volume applications. A wide selection of powered application equipment for extended-use, production operations is available.

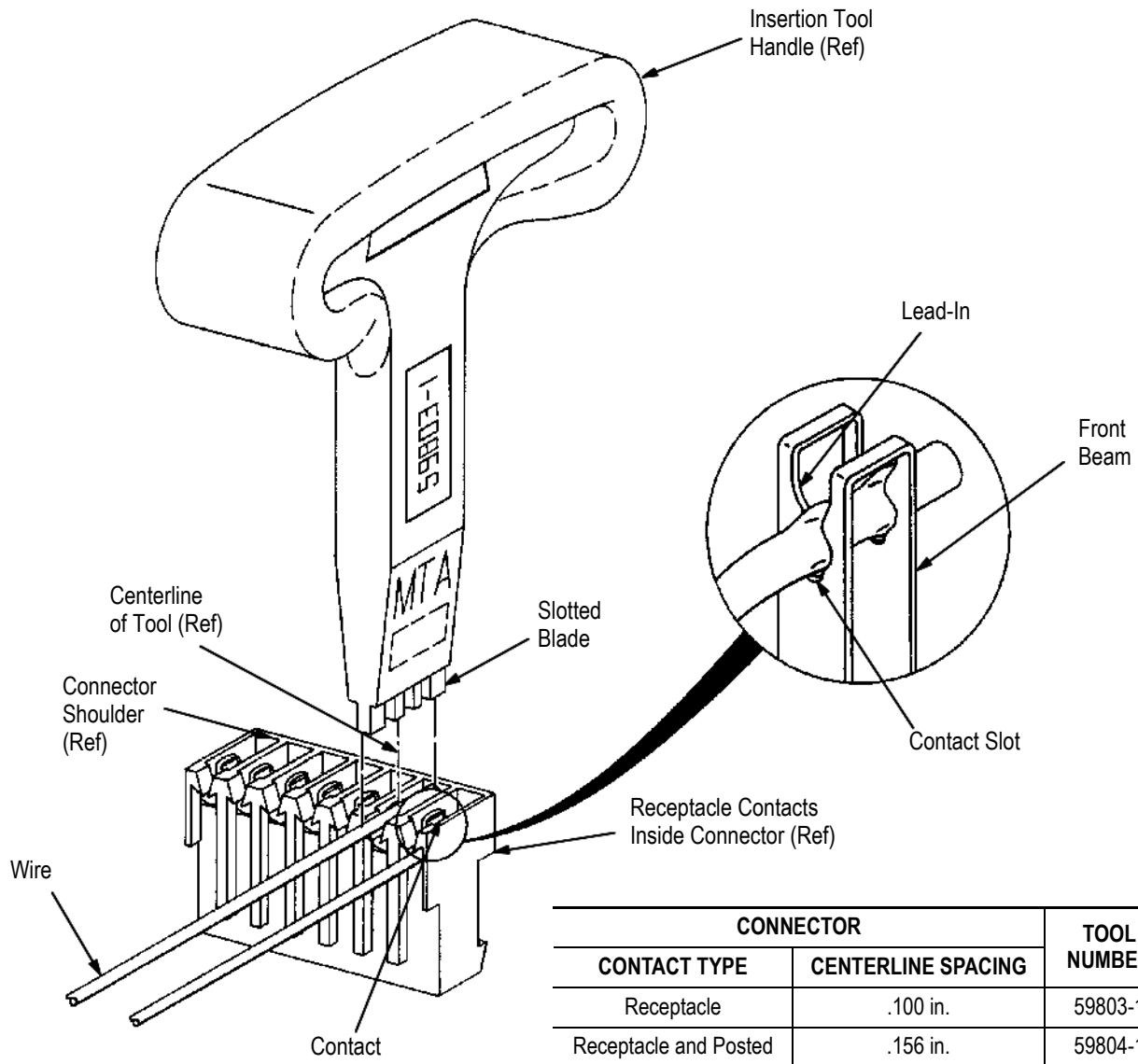
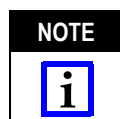

Figure 1

1. INTRODUCTION

This instruction sheet covers the use of Insertion Tools 59803-1 and 59804-1 designed to terminate .100-in. and .156-in. centerline MTA connectors. Read these instructions thoroughly before using the tools to ensure correct termination of the wire.



Dimensions in this instruction sheet are in metric units [with U.S. customary units in brackets]. Figures are not drawn to scale.

2. DESCRIPTION

The T-handle wire insertion tool is equipped with a slotted blade design which is used to insert the wire into the MTA connector. The blade is designed to fit into the connector slot to terminate the wire using the Displacement Terminating Technique.

This technique requires inserting an unstripped wire into a slotted contact beam to form a reliable electrical connection between the conductor and contact.

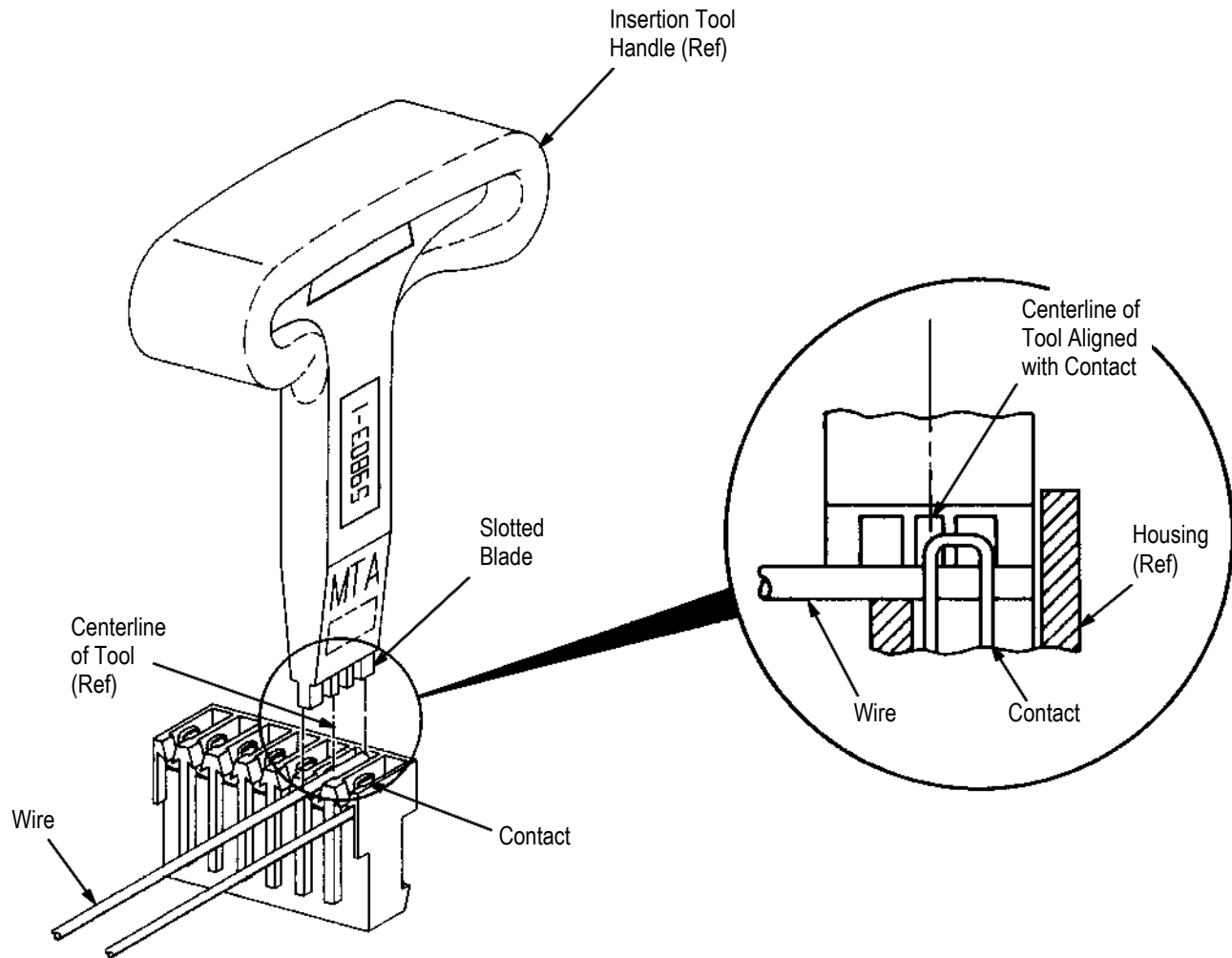

Figure 2

The tool number is stamped on the tool side and a logo marking is molded on both sides. Insertion tool 59803-1 is designed for connectors with contacts on .100-in. centers (MTA 100), and insertion tool 59804-1 is designed for connectors with .156-in centers (MTA 156).

3. INSERTION PROCEDURES (Figure 2)

1. Place the connector block on a flat surface or suitable support to prevent possible rocking when inserting the wire.
2. Position wire over the contact in the MTA connector. Make sure the end of the wire does not extend over the shoulder of the connector. Start the wire into contact with finger.

3. Place appropriate tool on wire over contact so that the centerline of the tool matches the contact. The tool must be positioned as shown in Figure 2.

4. Holding the tool handle perpendicular to the contact, apply a constant, direct pressure until the wire is terminated with the contact. Exert pressure in such a manner as to avoid contact damage.

5. Remove tool and inspect contact for proper wire insertion. If necessary, repeat the operation.

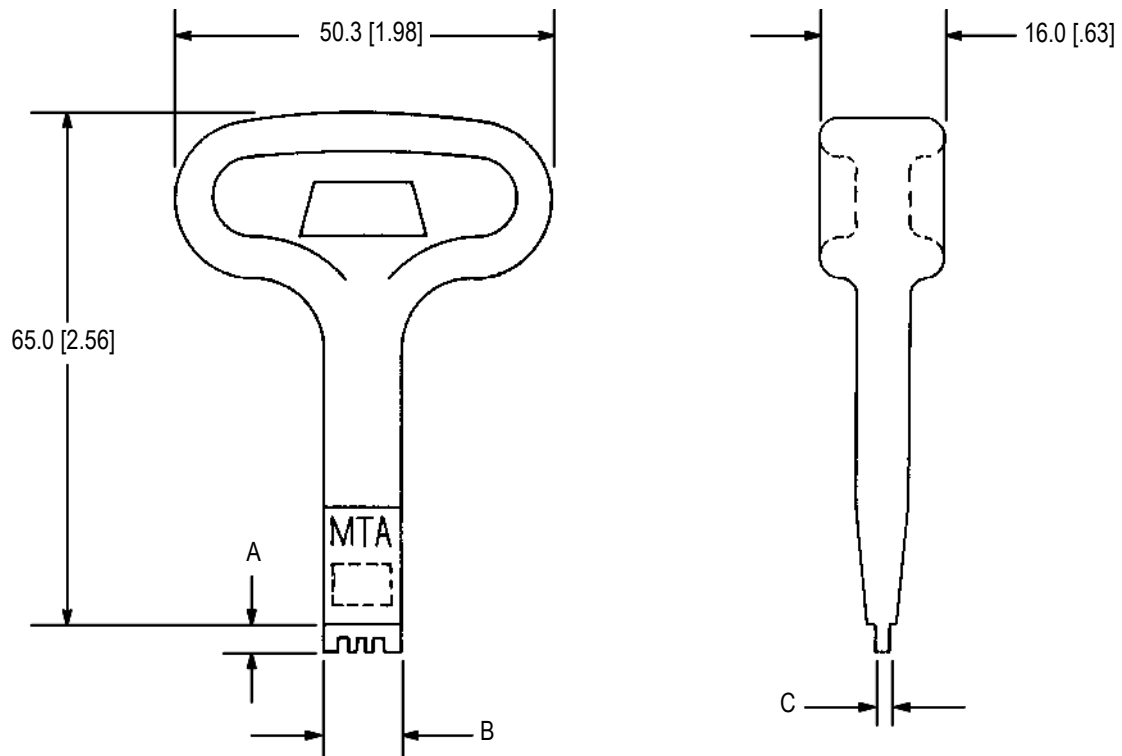

TOOL NUMBER	DIMENSIONS			PRODUCT DESIGNED FOR
	A	B	C	
59803-1	2.67 [.105]	7.11 [.280]	1.02 [.040]	MTA 100 Connector
59804-1	3.05 [.120]	9.53 [.375]	1.52 [.060]	MTA 156 Connector

Figure 3

4. TOOL INSPECTION

The insertion tools listed on this instruction sheet should be inspected with the information provided in Figure 3. We recommend that you inspect the tools immediately upon arrival at your facility, and at regularly scheduled intervals, to ensure that the tools have not been damaged during handling.

Additional tools can be purchased from:

CUSTOMER SERVICE (038-035)
 TYCO ELECTRONICS CORPORATION
 PO BOX 3608
 HARRISBURG PA 17105-3608

5. REVISION SUMMARY

Revisions to this instruction sheet include:

- Updated document to corporate requirements.