

THE INFORMATION CONTAINED IN THIS DRAWING IS THE SOLE PROPERTY OF BUD INDUSTRIES, INC. ANY REPRODUCTION IN PART OR WHOLE WITHOUT THE WRITTEN PERMISSION OF BUD INDUSTRIES, INC. IS PROHIBITED.

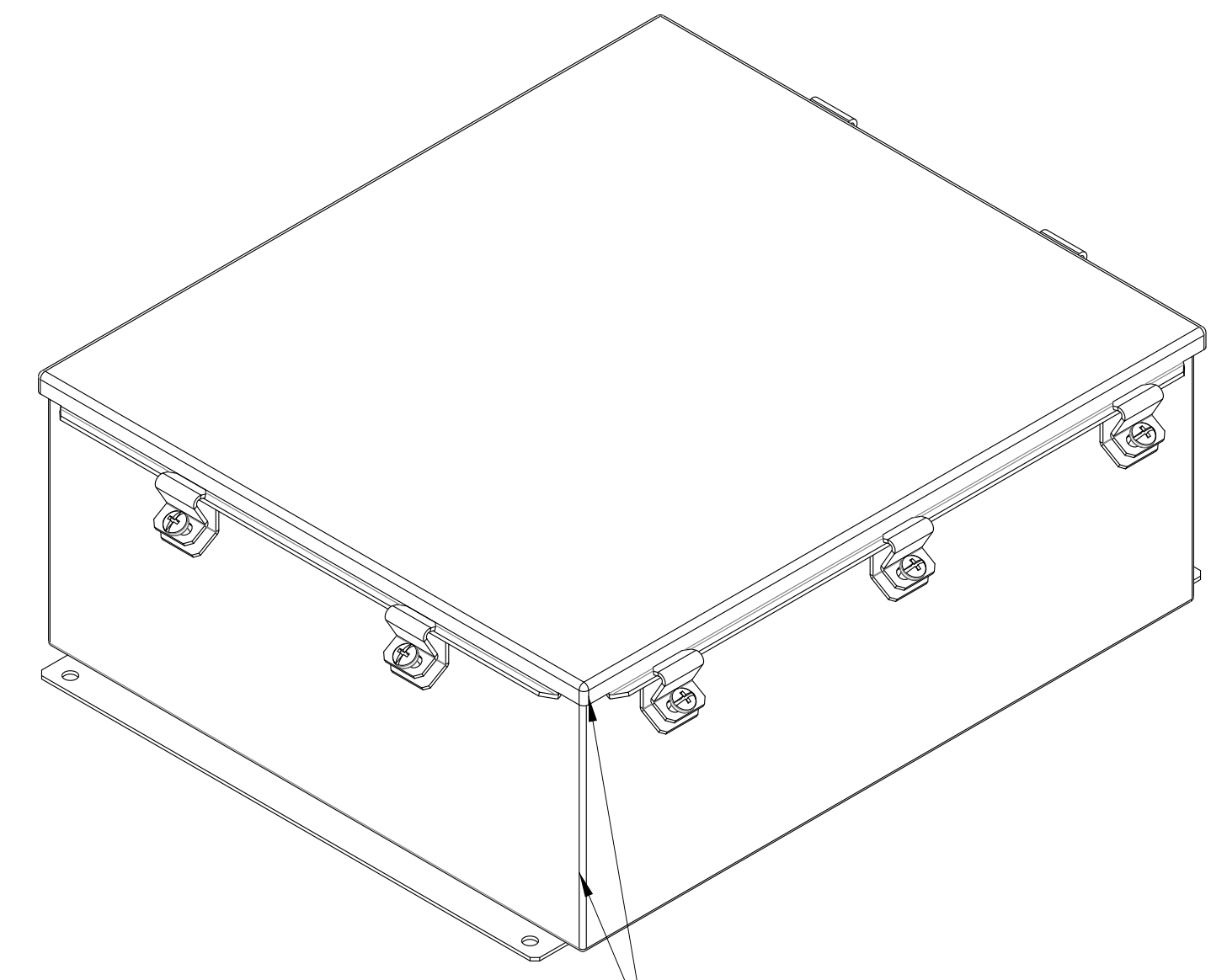

TEST ALL CORNER WELDS TO VERIFY CONTINUOUS SEAM WELD QUALITY

(F)

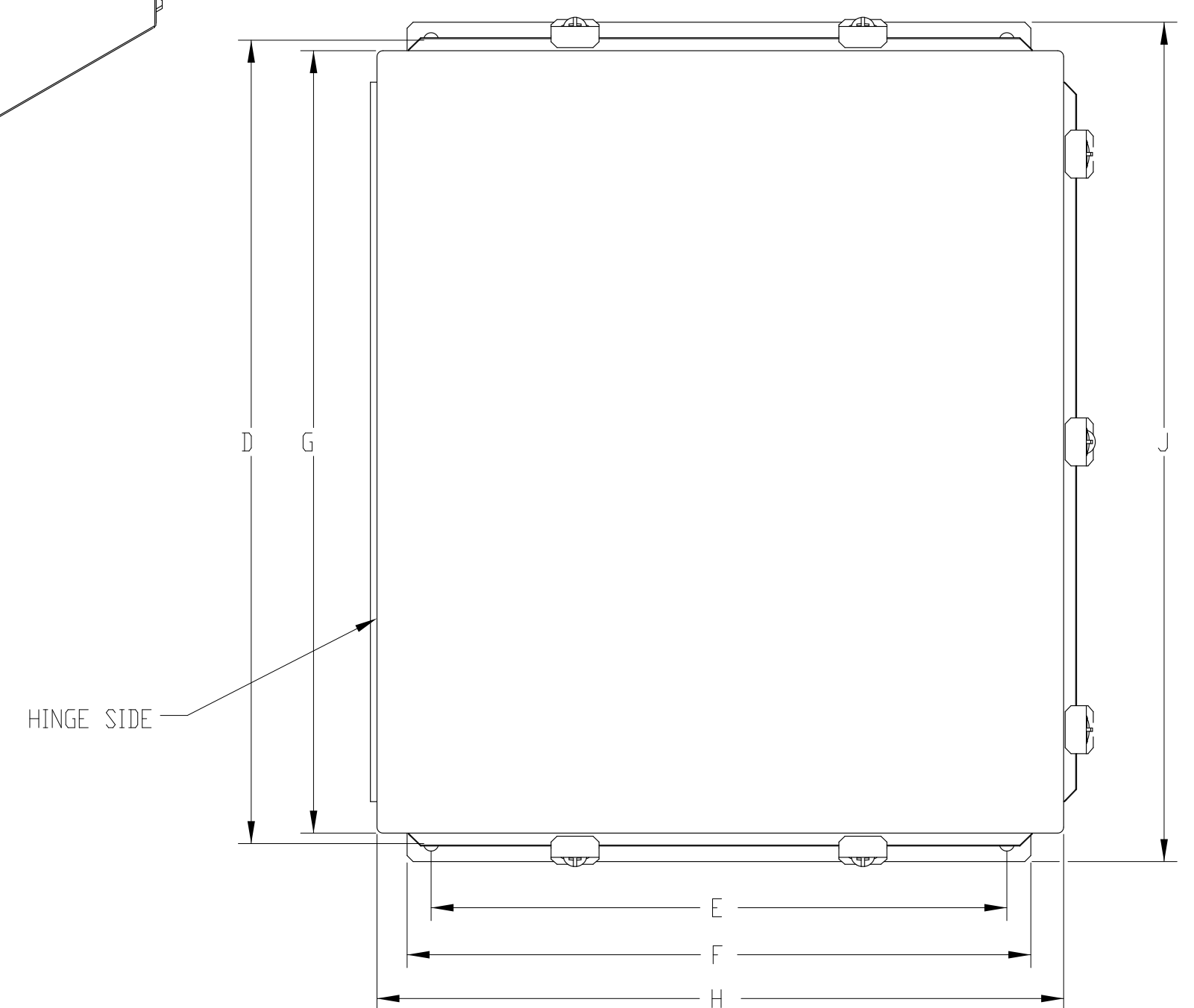

HINGE SIDE

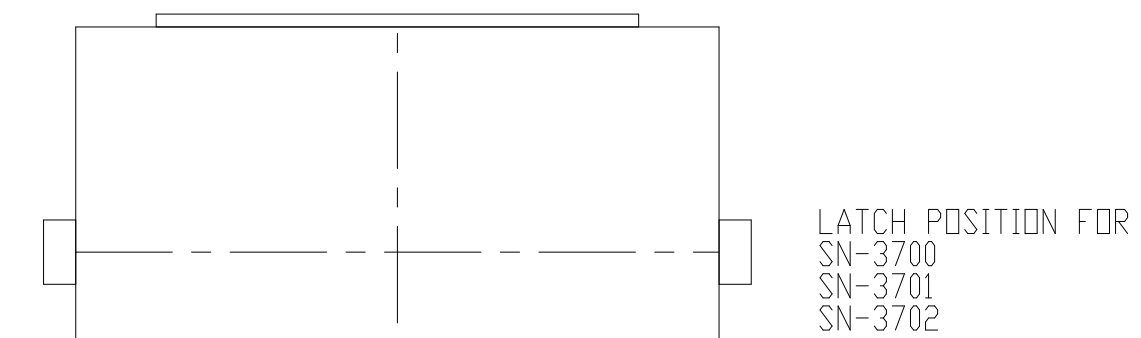
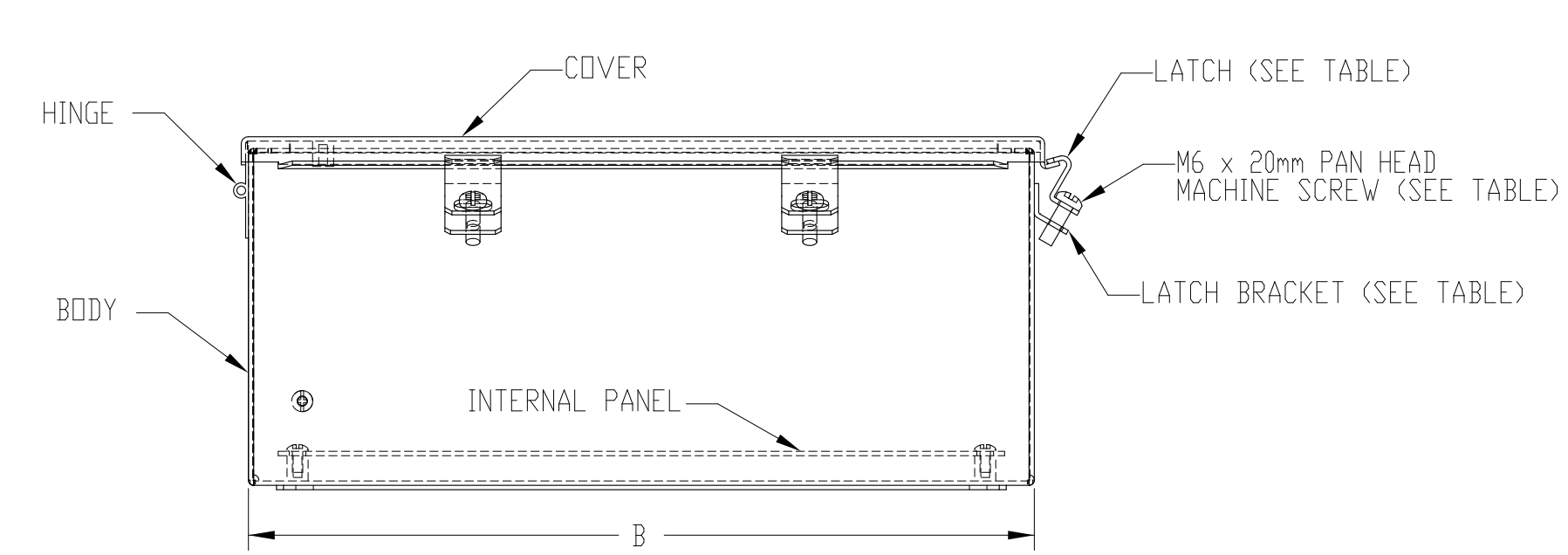
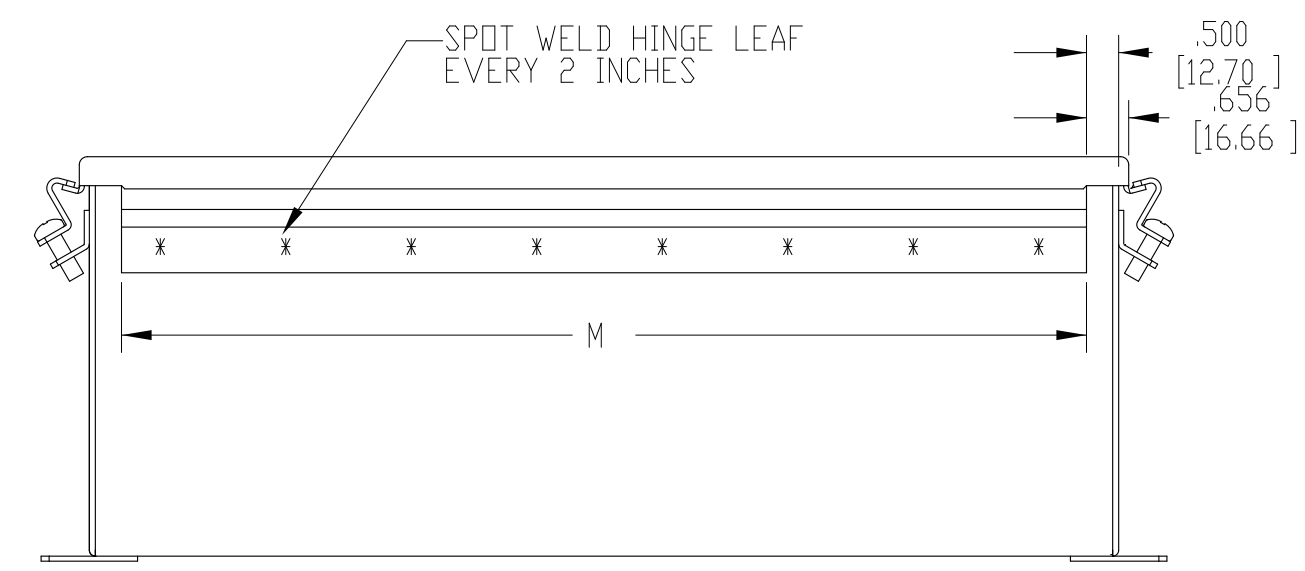

LATCH POSITION FOR SN-3700 SN-3701 SN-3702

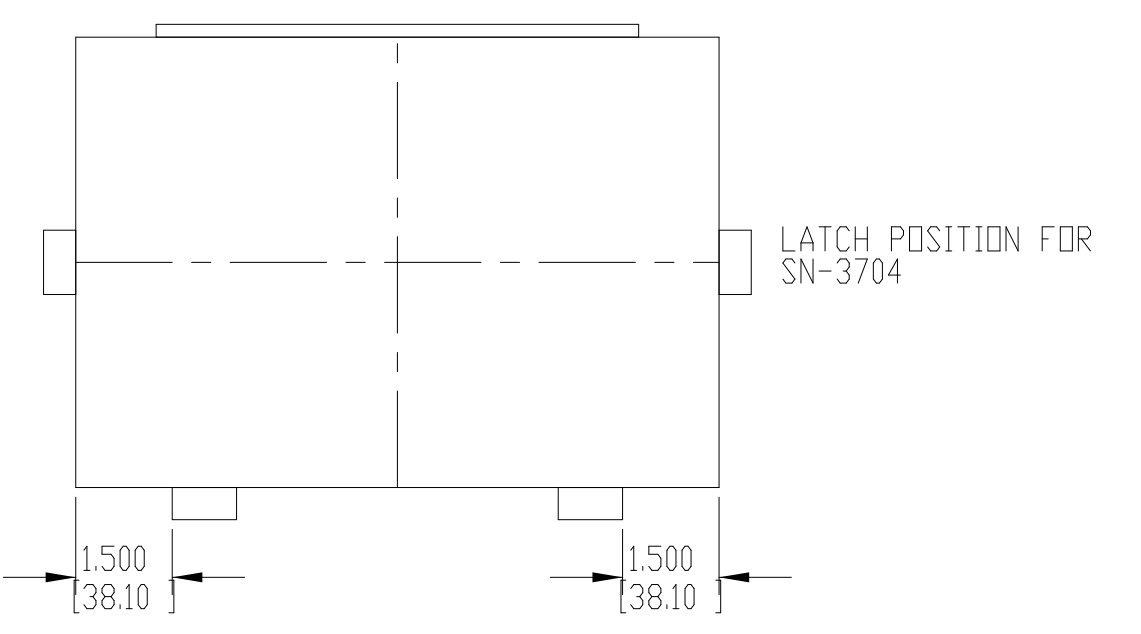

LATCH POSITION FOR SN-3704

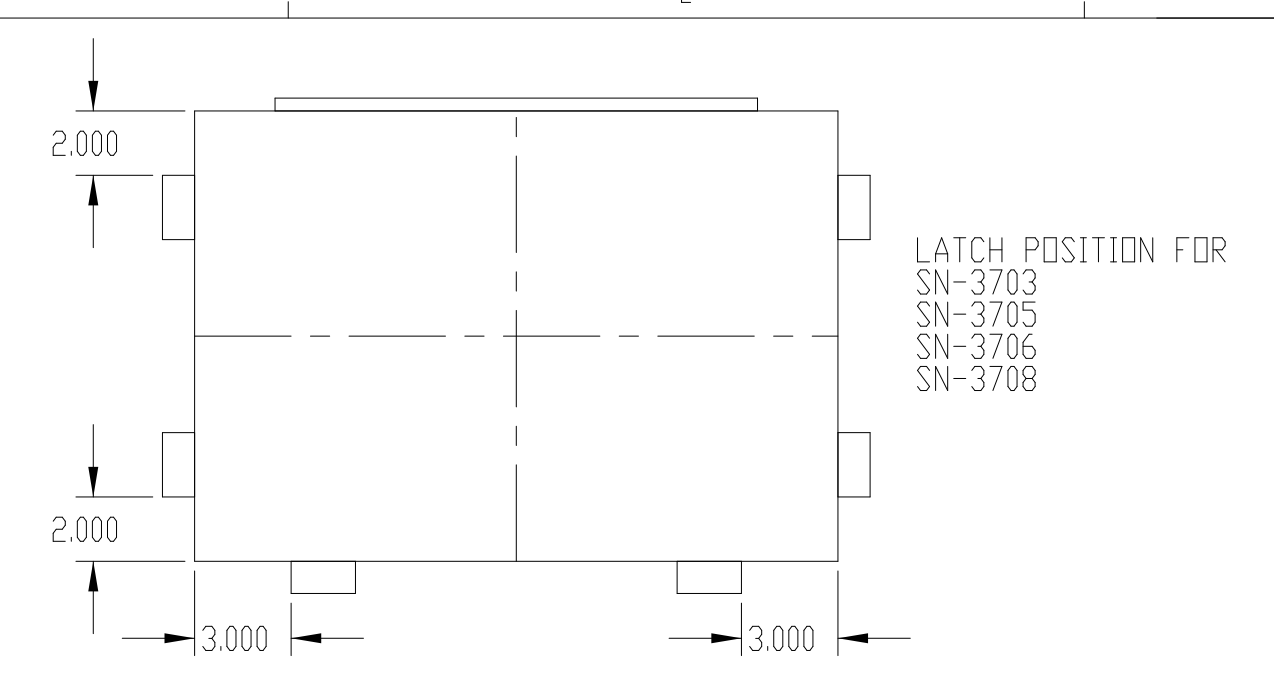

LATCH POSITION FOR SN-3703 SN-3705 SN-3706 SN-3708

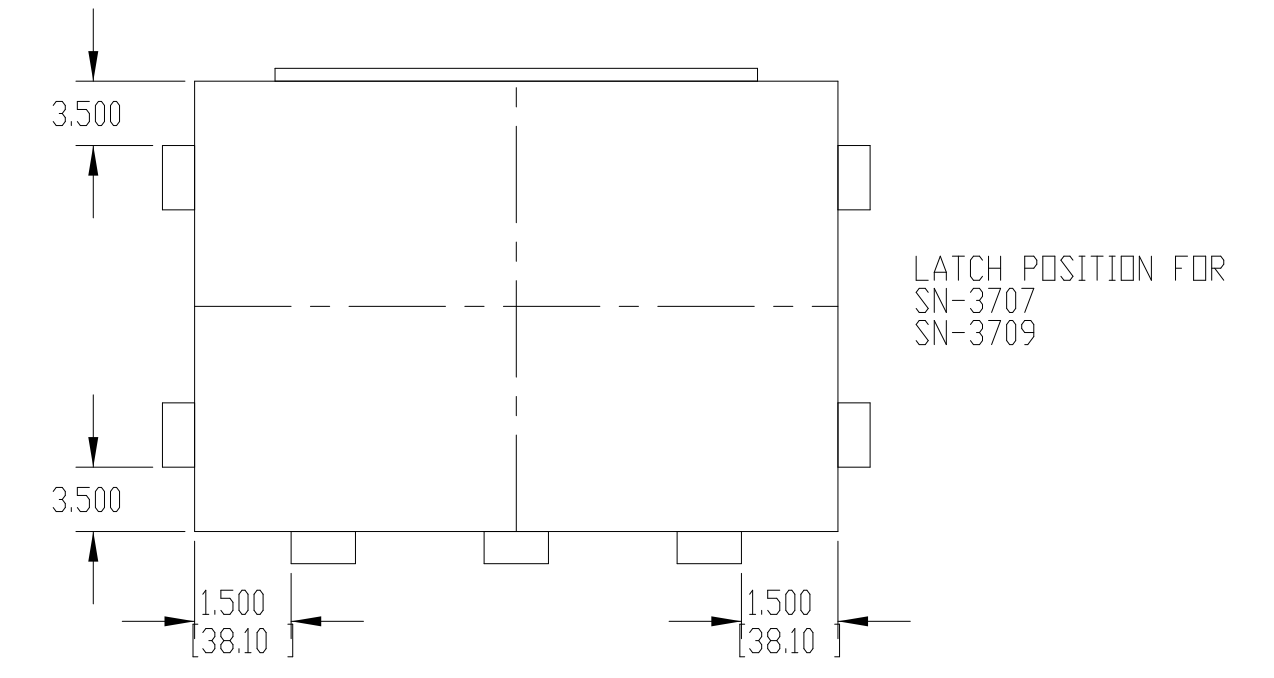

LATCH POSITION FOR SN-3707 SN-3709

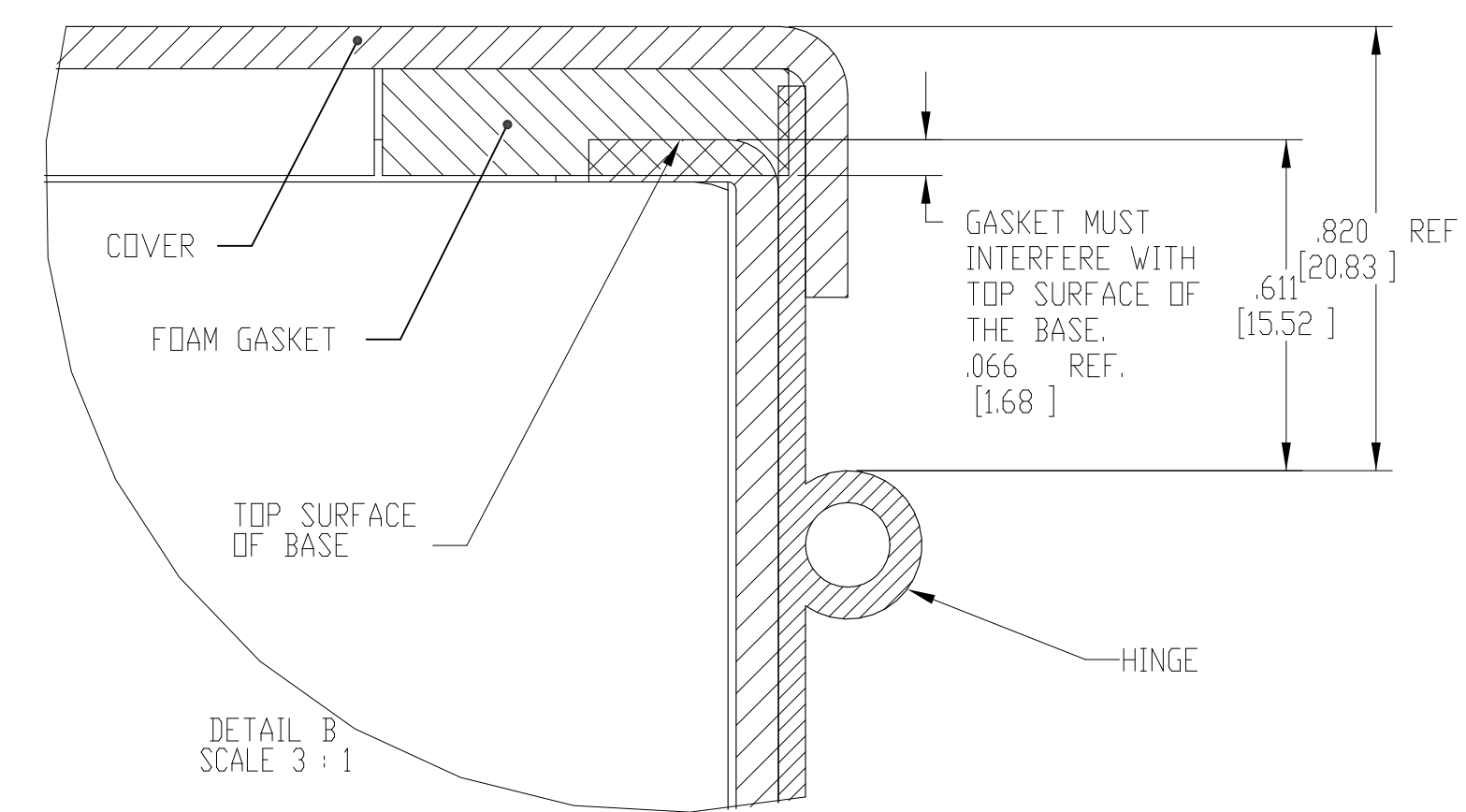

DETAIL B SCALE 3 : 1

GASKET MUST INTERFERE WITH TOP SURFACE OF THE BASE. .820 REF [20.83] .61 [15.52] .066 REF. [1.68]

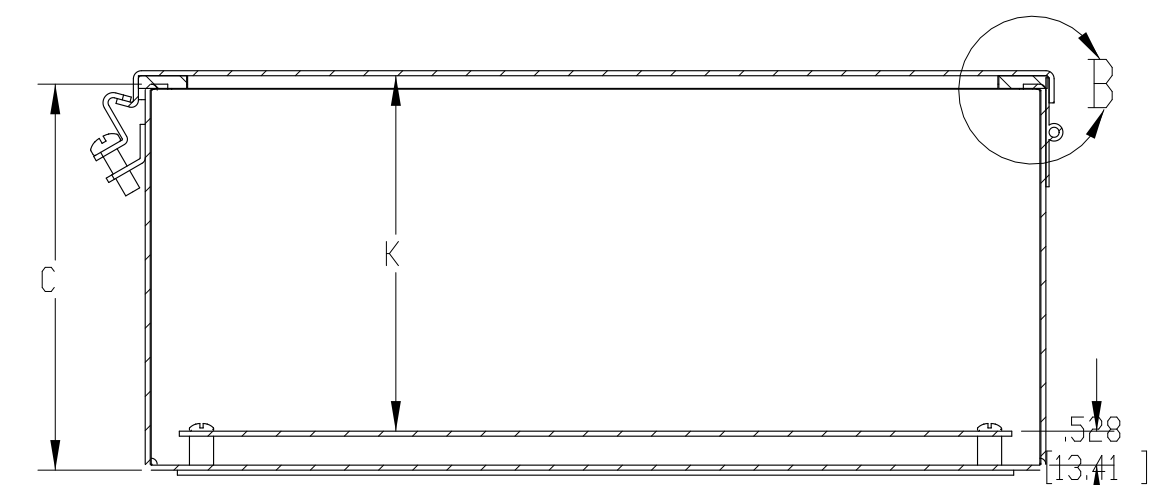
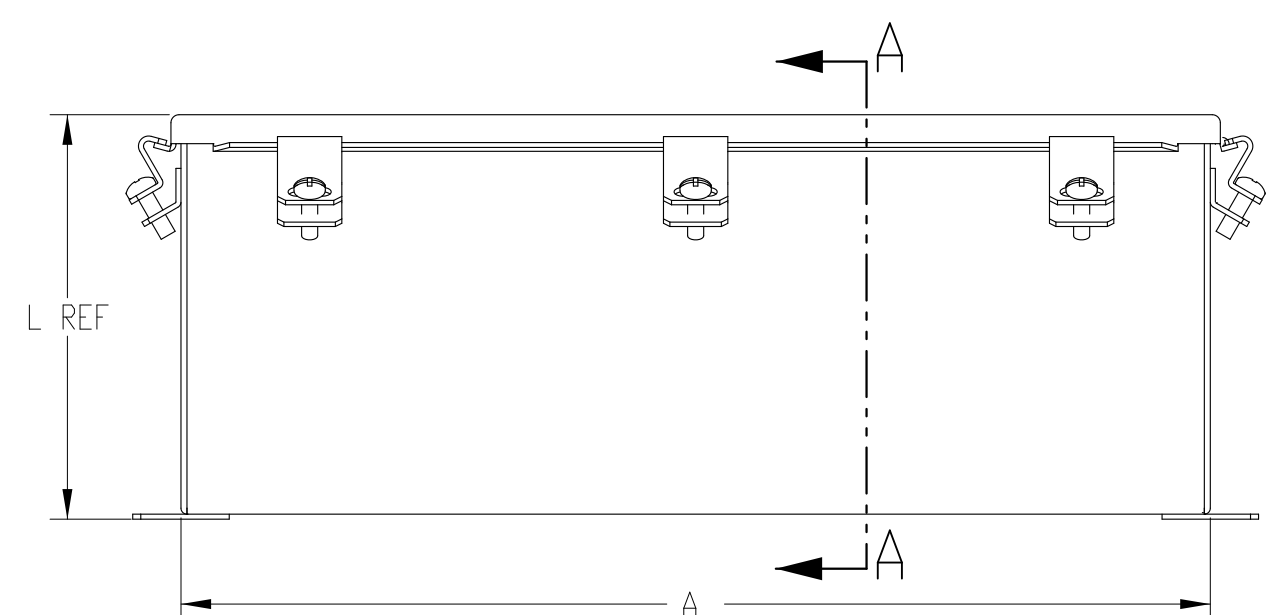

SECTION A-A

(G)

PART #	A	B	C	D	E	F	G	H	J	K	L	M	PANEL SIZE	# OF BRACKETS, SCREWS/LATCHES
SN-3700	8.00[152.4]	4.00[101.6]	3.00[76.2]	8.75[171.5]	2.00[50.8]	3.00[76.2]	6.31[160.2]	4.31[109.5]	7.50[190.5]	2.52[64]	3.25[82.6]	5[127]	4.90 X 2.90	3
SN-3701	8.00[203.2]	6.00[152.4]	3.50[88.9]	8.75[222.3]	4.00[101.6]	5.00[127]	8.31[211.1]	6.31[160.3]	9.50[241.3]	3.02[76.7]	3.75[96.3]	7[179]	6.90 X 4.90	3
SN-3702	8.00[152.4]	6.00[152.4]	4.00[101.6]	8.75[171.5]	4.00[101.6]	5.00[127]	6.31[160.2]	6.31[160.3]	7.50[190.5]	3.52[89.4]	4.25[108]	5[127]	4.90 X 4.90	3
SN-3703	12.00[304.8]	10.00[254]	5.00[127]	12.75[323.9]	8.00[203.2]	9.00[228.6]	12.31[312.7]	10.31[261.9]	13.50[342.9]	4.52[114.8]	5.25[133.4]	11[279.4]	10.90 X 8.90	6
SN-3704	10.00[254]	8.00[203.2]	6.00[152.4]	10.75[273]	6.00[152.4]	7.00[177.8]	10.31[261.9]	8.31[211.1]	11.50[292.1]	5.52[140.2]	6.25[158.8]	9[228.6]	8.90 X 6.90	4
SN-3705	12.00[304.8]	12.00[304.8]	6.00[152.4]	12.75[323.9]	10.00[254]	11.00[279.4]	12.31[312.7]	12.31[312.7]	13.50[342.9]	5.52[140.2]	6.25[158.8]	11[279.4]	10.90 X 10.90	6
SN-3706	14.00[355.6]	12.00[304.8]	6.00[152.4]	14.75[374.6]	10.00[254]	11.00[279.4]	14.31[363.5]	12.31[312.7]	15.50[393.7]	5.52[140.2]	6.25[158.8]	13[330.2]	12.90 X 10.90	6
SN-3707	16.00[406.4]	14.00[355.6]	6.00[152.4]	16.75[425.5]	12.00[304.8]	13.00[330.2]	16.31[414.3]	14.31[363.5]	17.5[444.5]	5.52[140.2]	6.25[158.8]	15[381]	14.90 X 12.90	7
SN-3708	14.00[355.6]	12.00[304.8]	8.00[203.2]	14.75[374.6]	10.00[254]	11.00[279.4]	14.31[363.5]	12.31[312.7]	15.50[393.7]	7.52[191]	8.25[209.6]	13[330.2]	12.90 X 10.90	6
SN-3709	16.00[406.4]	14.00[355.6]	10.00[254]	16.75[425.5]	12.00[304.8]	13.00[330.2]	16.31[414.3]	14.31[363.5]	17.50[444.7]	9.52[241.8]	10.25[260.4]	15[381]	14.90 X 12.90	7

MATERIAL:  
 BODY, MOUNTING BRACKETS, COVER & INTERNAL PANEL - 14 GA. STEEL  
 LATCHES - 14 GA. STAINLESS STEEL  
 LATCH BRACKETS - 18 GA. STAINLESS STEEL  
 CONTINUOUS HINGE - 18 GA. STEEL WITH Ø .125 STEEL PIN  
 GASKET - ROGERS CORPORATION PORDN 4701-41-15250 3M 9832  
 CLOSED CELL URETHANE FOAM WITH ADHESIVE ON ONE SIDE.  
 SCREWS - STAINLESS STEEL

FINISH:  
 ENCLOSURE, INTERNAL PANEL - SMOOTH GRAY POWDERCOAT  
 DUPONT POWDER COATINGS PART NO. PFH-502-S8 DR EQUIVALENT  
 UL TYPE DTV2 COATING TO BE APPLIED AND BAKED AT 8-10 MIN.  
 AT 400°F. TO A MINIMUM DRY FILM THICKNESS OF 1.5 MILS (0.0015 IN.)  
 LATCHES & SCREWS - NATURAL

DIMENSIONS ARE INCH[MM]

TOLERANCE		PARTS LIST	
UNLESS OTHERWISE SPECIFIED	±.039 [1.0mm]	APPROVALS	DATE
		DP	1-3-06
MATERIAL	AS NOTED	CHECKED	
FINISH	AS NOTED	APPROVED	
DO NOT SCALE DRAWING			

BU D INDUSTRIES INC.  
 NEMA SHEET METAL BOX

SIZE/DWG. NO. SN-3700  
 SCALE: 1:1  
 SHEET 1 OF 1

THE INFORMATION CONTAINED IN THIS DRAWING IS THE SOLE PROPERTY OF BUD INDUSTRIES, INC. ANY REPRODUCTION IN PART OR WHOLE WITHOUT THE WRITTEN PERMISSION OF BUD INDUSTRIES, INC. IS PROHIBITED.

FIG. NO.	SN-3700
ISSUE	REVISIONS
	SEE SHEET 1

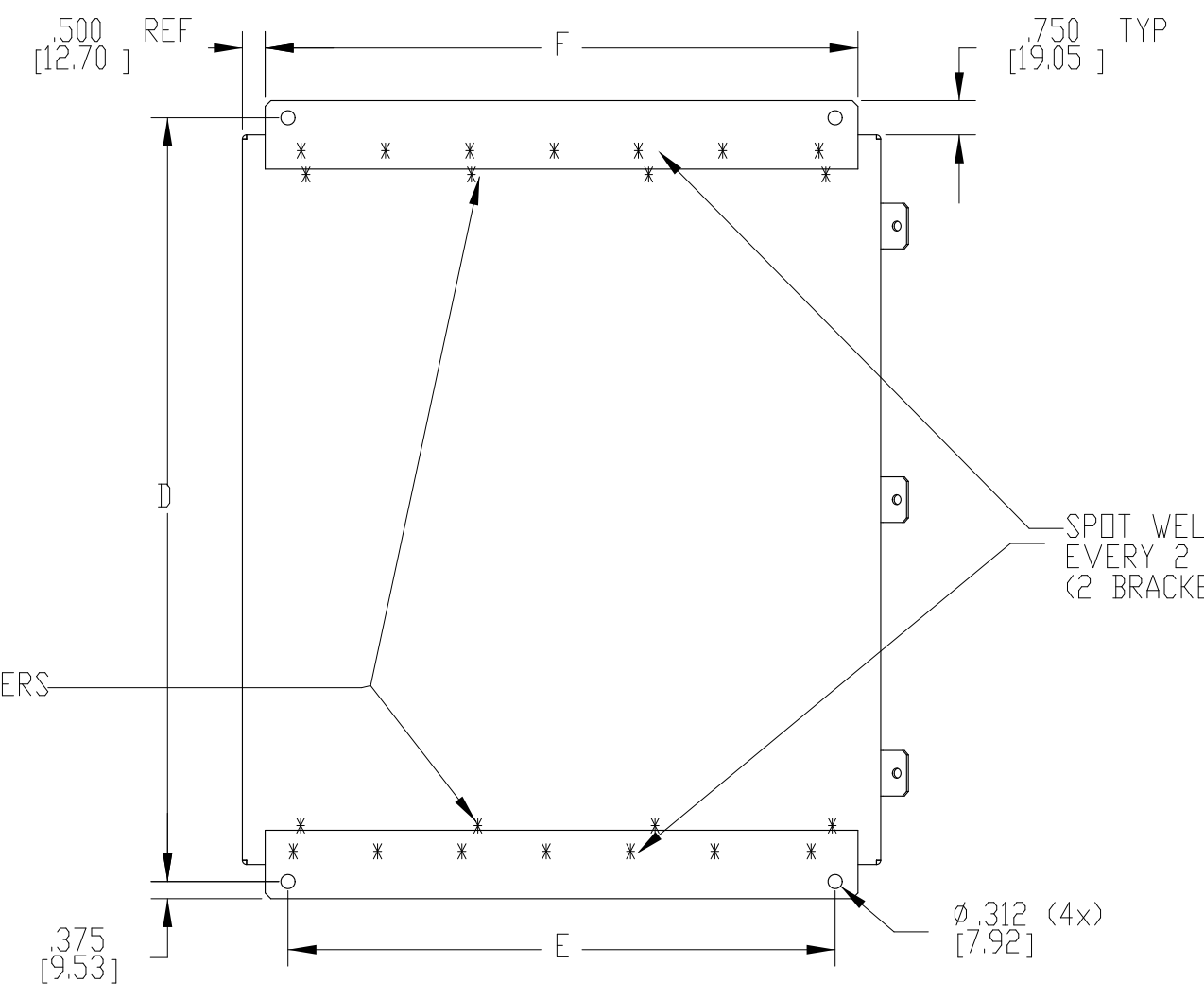
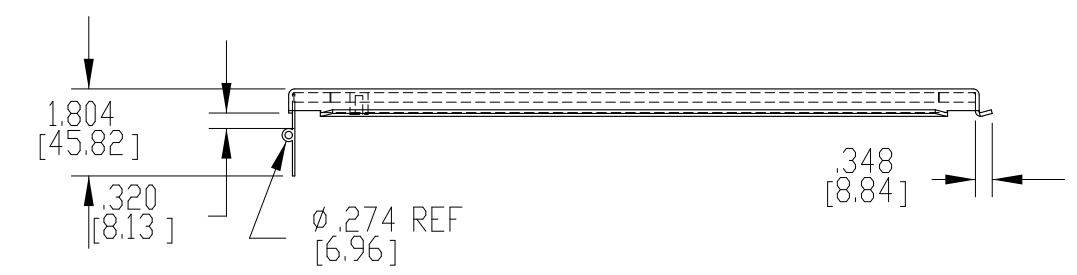
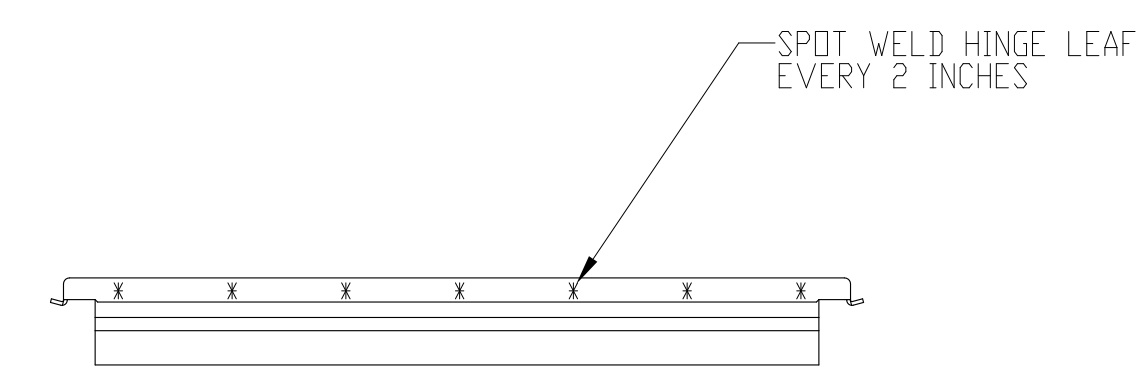
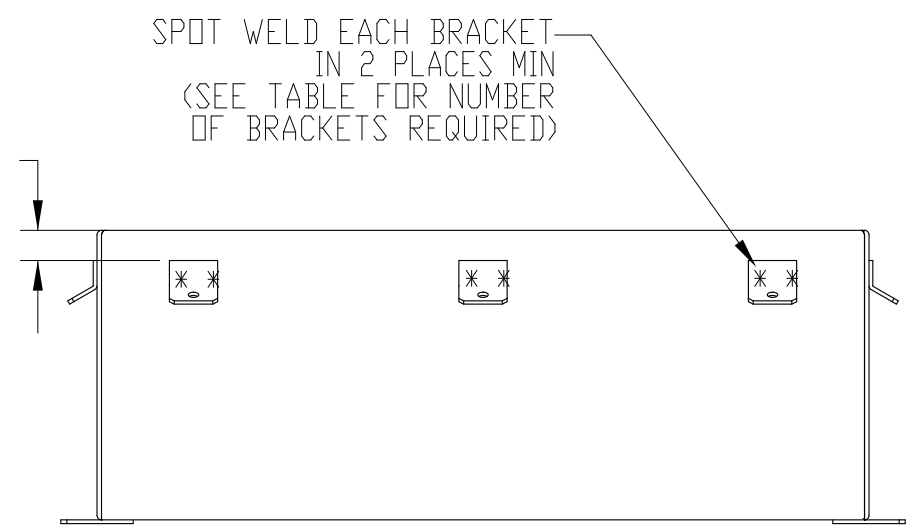
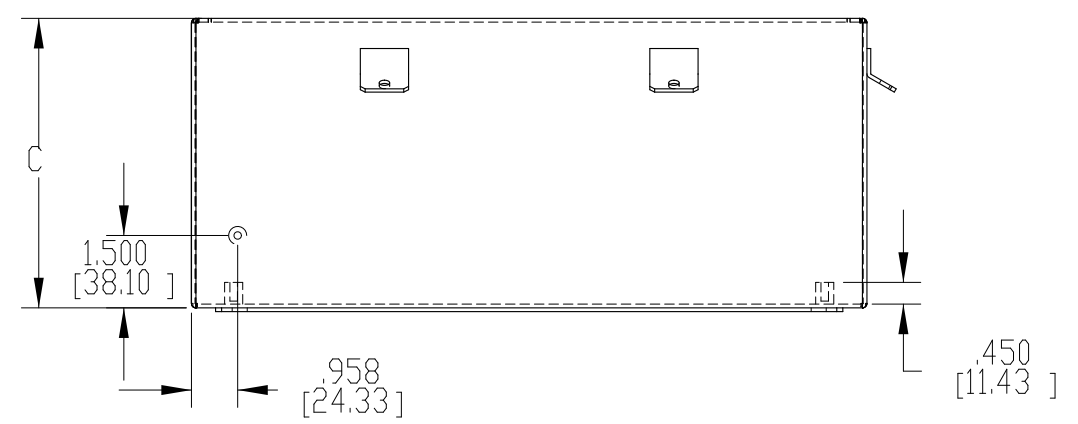
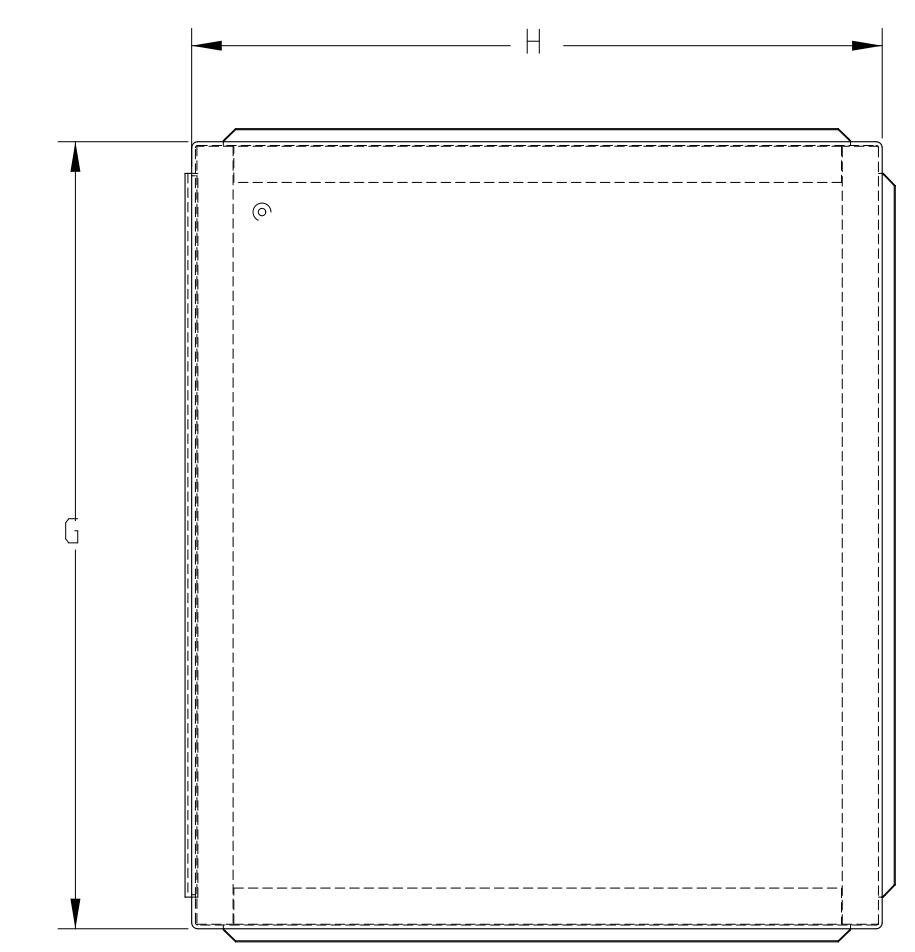
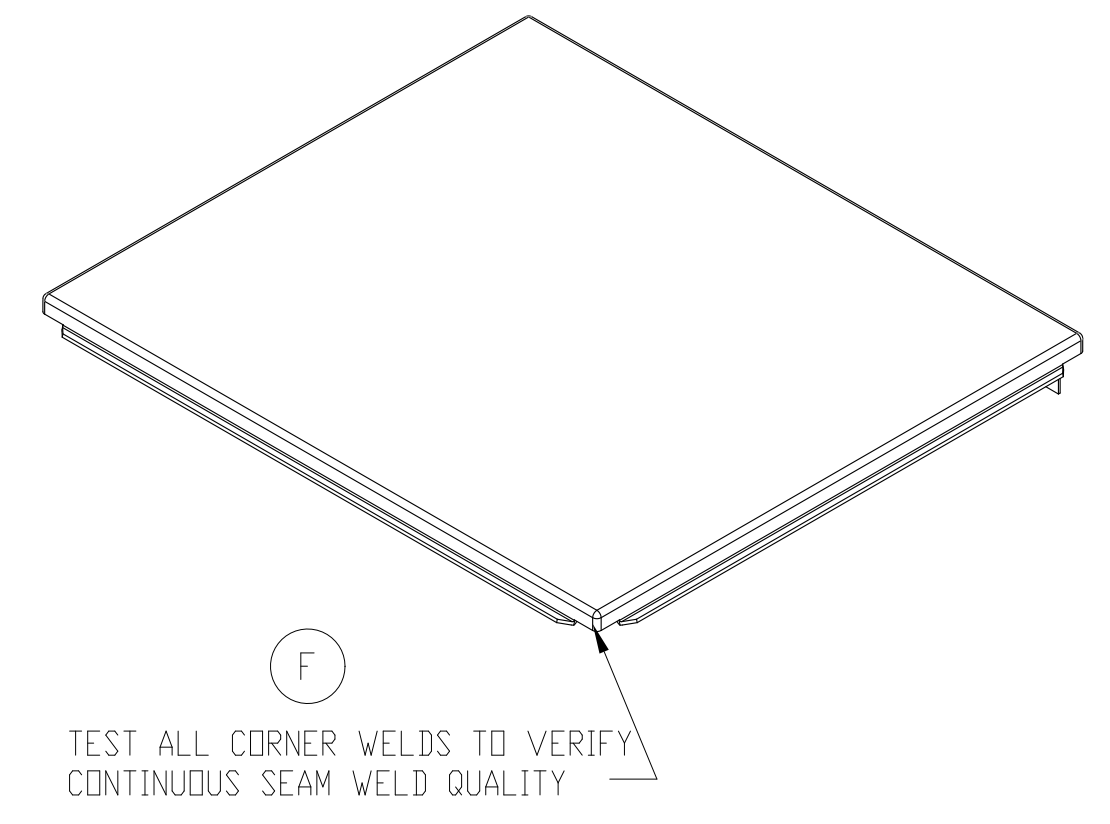
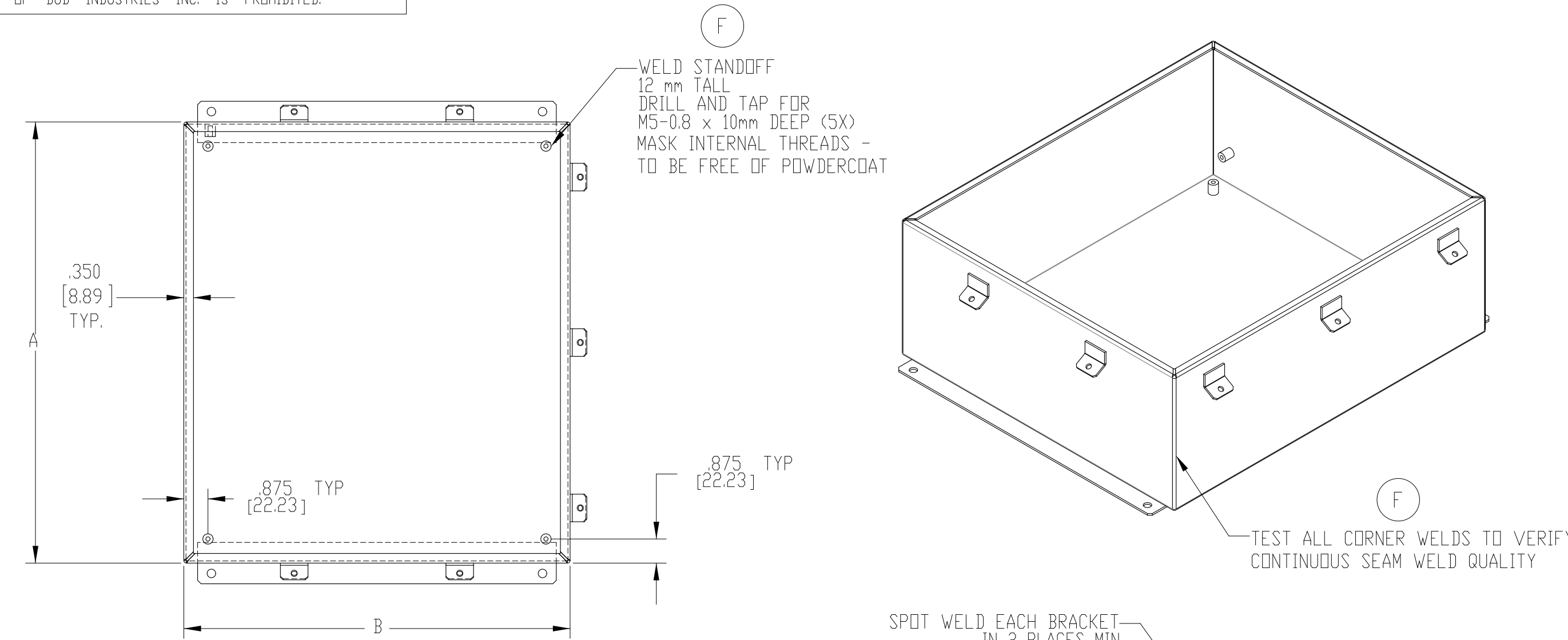

ADDITIONAL TACK WELD EDGE OF MOUNTING BRACKETS TO BODY EQUALLY SPACED 3 PLACES ON 3700-BA 4 PLACES ON ALL OTHERS

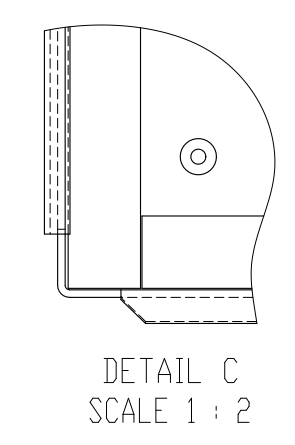
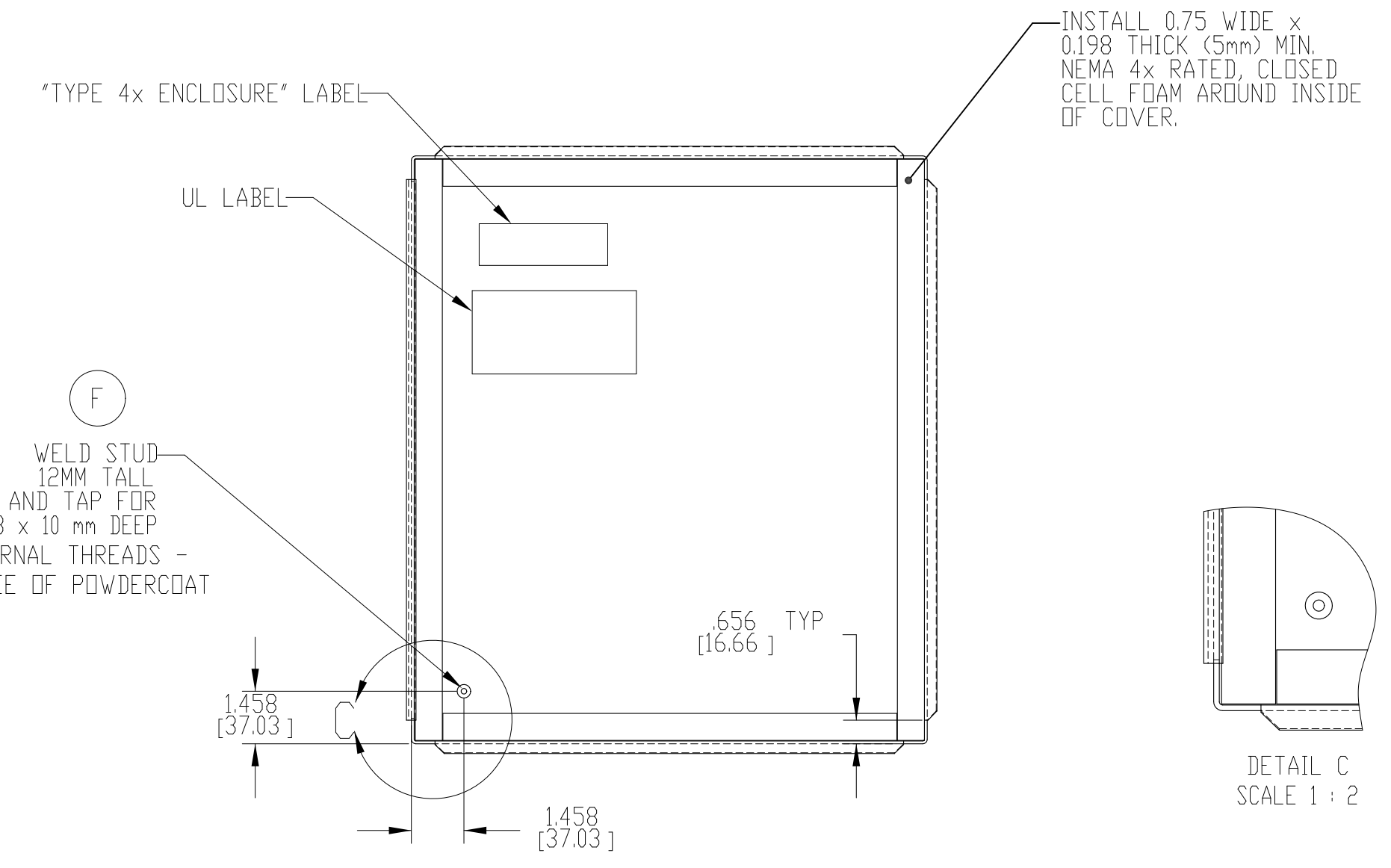

BODY ASSEMBLY						
PART NUMBER	A	B	C	D	E	F
3700-BA	6[152.4]	4[101.6]	3[76.2]	6.75[171.5]	2[50.8]	3[76.2]
3701-BA	8[203.2]	6[152.4]	3.5[88.9]	8.75[222.3]	4[101.6]	5[127]
3702-BA	6[152.4]	6[152.4]	4[101.6]	6.75[171.5]	4[101.6]	5[127]
3703-BA	12[304.8]	10[254]	5[127]	12.75[323.9]	8[203.2]	9[228.6]
3704-BA	10[254]	8[203.2]	6[152.4]	10.75[273]	6[152.4]	7[177.8]
3705-BA	12[304.8]	12[304.8]	6[152.4]	12.75[323.9]	10[254]	11[279.4]
3706-BA	14[355.6]	12[304.8]	6[152.4]	14.75[374.7]	10[254]	11[279.4]
3707-BA	16[406.4]	14[355.6]	6[152.4]	16.75[425.5]	12[304.8]	13[330.2]
3708-BA	14[355.6]	12[304.8]	8[203.2]	14.75[374.7]	10[254]	11[279.4]
3709-BA	16[406.4]	14[355.6]	10[254]	16.75[425.5]	12[304.8]	13[330.2]

COVER ASSEMBLY		
PART NUMBER	G	H
3700-CA	6.31[160.3]	4.31[109.5]
3701-CA	8.31[211.1]	6.31[160.3]
3702-CA	6.31[160.3]	6.31[160.3]
3703-CA	12.31[312.7]	10.31[261.9]
3704-CA	10.31[261.9]	8.31[211.1]
3705-CA	12.31[312.7]	12.31[312.7]
3706-CA	14.31[363.5]	12.31[312.7]
3707-CA	16.31[414.3]	14.31[363.5]
3708-CA	14.31[363.5]	12.31[312.7]
3709-CA	16.31[414.3]	14.31[363.5]

PARTS LIST			
TOLERANCE	CAD GENERATED DRAWING, DO NOT MANUALLY UPDATE	BUD INDUSTRIES, INC.	
UNLESS OTHERWISE SPECIFIED	APPROVALS	DATE	
	DRAWN	1-3-06	
MATERIAL	CHECKED	NEMA STEEL METAL BOX	
AS NOTED	APPROVED		
FINISH	AS NOTED		
DO NOT SCALE DRAWING		SIZE/DWG. NO.	SN-3700
		SCALE	1:1
		REV.	G
		SHEET	2 OF 2

QTY.	USED ON
------	---------