

Helping Customers Innovate, Improve & Grow

VX-705

Description

The VX-705 is a Voltage Control Crystal Oscillator that operates at the fundamental frequency of the internal crystal. The crystal is a high-Q quartz device that enables the circuit to achieve low phase noise jitter performance over a wide operating temperature range. The VX-705 is housed in an industry standard hermetically sealed LCC package and is available in tape and reel.

Features

- CMOS or LVPECL output VCXO
- Output Frequencies from 77.76 MHz to 170 MHz
- 3.3 V Operation
- Fundamental Crystal Design with Low Jitter Performance
- Output Disable Feature
- Excellent ± 20 ppm Temperature Stability,
- 0/70°C, -20/70°C or -40/85°C Operating Temperature
- Small Industry Standard Package, 5.0x7.0
- Product is free of lead and compliant to EC RoHS Directive 

Applications

- LTE
- SONET/SDH/DWDM
- Ethernet, SyncE, GE
- xDSL, PCMA
- Digital Video
- Broadband Access
- Base Stations, Picocells
- Test and Measurement

Block Diagram

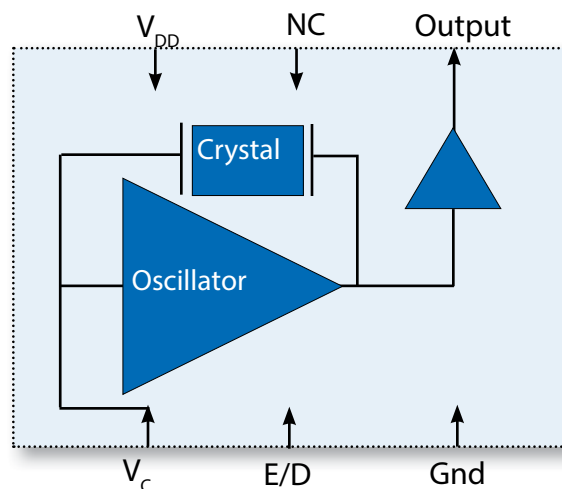
Figure 1. Block Diagram

Performance Specifications

Table 1. Electrical Performance - 3.3V CMOS

Parameter	Symbol	Min	Typical	Maximum	Units
Supply					
Voltage ¹	V_{DD}	3.135	3.3	3.465	V
Current ²	I_{DD}		10	25	mA
Frequency					
Nominal Frequency ³	f_N	80.00		170.00	MHz
Absolute Pull Range ^{2,6} , <i>ordering option</i>	APR	± 30 or ± 50			ppm
Linearity ²	Lin		5		%
Gain Transfer ²	K_V	+80			ppm/V
Temperature Stability	f_{STAB}		± 20		ppm
Outputs					
Output Logic Levels ² Output Logic High Output Logic Low	V_{OH} V_{OL}	$0.9 * V_{DD}$		$0.1 * V_{DD}$	V
Load	I_{OUT}			15	pF
Rise Time ^{2,4}	t_R			5	ns
Fall Time ^{2,4}	t_F			5	ns
Symmetry ²	SYM	45	50	55	%
Jitter, RMS ^{5,7} (12kHz to 20 MHz)	ϕ_J		80	200	fsec
Phase Noise ⁸ (122.88 MHz) 10Hz 100Hz 1kHz 10kHz 100kHz 1MHz 10MHz			-66 -98 -124 -138 -151 -158 -161		dBc/Hz
Control Voltage					
Control Voltage Range for Pull Range	V_C	0.3		3.0	V
Control Voltage Input Impedance	Z_{IN}	1			M Ω
Control Voltage Modulation BW	BW	10			kHz
Output Enable/Disable ⁹ Output Enabled Output Disabled	V_{IH} V_{IL}	$0.9 * V_{DD}$		$0.1 * V_{DD}$	V
Start-Up Time	T_S			10	ms
Operating Temp, Ordering Option	T_{OP}	0/70, -20/70 or -40/85			°C
Package Size		5.0 x 7.0 x 1.8			mm

- 1] The power supply should have by-pass capacitors as close to the supply and to ground as possible, for examples 0.1 and 0.01uF
- 2] Parameters are tested with production test circuit as shown in Figure 2.
- 3] See Standard Frequencies and Ordering Information tables for more specific information
- 4] Measured from 20% to 80% of a full output swing as shown in Figure 4.
- 5] Not tested in production, guaranteed by design, verified at qualification.
- 6] Tested with $V_C = 0.3V$ to $3.0V$ unless otherwise stated in part description
- 7] Broadband Period Jitter measured using Wavecrest SIA3300C, 90K samples.
- 8] Phase Noise is measured with an Agilent E5052A.
- 9] The Output is Enabled if the Enable/Disable is left open.

Performance Specifications

Table 2. Electrical Performance - 3.3V LVPECL

Parameter	Symbol	Min	Typical	Maximum	Units
Supply					
Voltage ¹	V_{DD}	3.135	3.3	3.465	V
Current ²	I_{DD}		50	90	mA
Frequency					
Nominal Frequency ³	f_N	77.76		170.00	MHz
Absolute Pull Range ^{2,6} , <i>ordering option</i>	APR	$\pm 30, \pm 50$			ppm
Linearity ²	Lin		5		%
Gain Transfer ²	K_V	+80			ppm/V
Temperature Stability	f_{STAB}		± 20		ppm
Outputs					
Output Logic Levels ² Output Logic High Output Logic Low	V_{OH} V_{OL}	$V_{DD} - 1.025$ $V_{DD} - 1.810$	$V_{DD} - 0.950$ $V_{DD} - 1.700$	$V_{DD} - 0.880$ $V_{DD} - 1.620$	V
Rise Time ^{2,4}	t_R		0.6	1	ns
Fall Time ^{2,4}	t_F		0.6	1	ns
Symmetry ²	SYM	45	50	55	%
Jitter, RMS ^{5,8} (12kHz to 20 MHz)	ϕ_J		0.3	1	ps
Jitter, RMS ^{5,8} (10kHz to 1MHz)	ϕ_J		0.2	0.3	ps
Phase Noise ⁸ 10Hz 100Hz 1kHz 10kHz 100kHz 1MHz 10MHz			-60 -88 -118 -131 -145 -153 -156		dBc/Hz
Control Voltage					
Control Voltage Range for Pull Range	V_C	0.3		3.0	V
Control Voltage Input Impedance	Z_{IN}	1			M Ω
Control Voltage Modulation BW	BW	10			kHz
Output Enable/Disable ⁹ Output Enabled, Option A Output Disabled, Option A	V_{IH} V_{IL}	$0.9 * V_{DD}$		$0.1 * V_{DD}$	V
Start-Up Time	T_S			10	ms
Operating Temp, Ordering Option	T_{OP}	0/70, -20/70, or -40/85			°C
Package Size		5.0 x 7.0 x 1.8			mm

- 1] The power supply should have by-pass capacitors as close to the supply and to ground as possible, for examples 0.1 and 0.01uF
- 2] Parameters are tested with production test circuit below as shown in Figure 3.
- 3] See Standard Frequencies and Ordering Information tables for more specific information
- 4] Measured from 20% to 80% of a full output swing as shown in Figure 4.
- 5] Not tested in production, guaranteed by design, verified at qualification.
- 6] Tested with $V_C = 0V$ to 3.3V unless otherwise stated in part description
- 7] Broadband Period Jitter measured using Wavecrest SIA3300C, 90K samples.
- 8] Phase Noise is measured with an Agilent E5052A.
- 9] The Output is Enabled if the Enable/Disable is left open.

Test Circuits

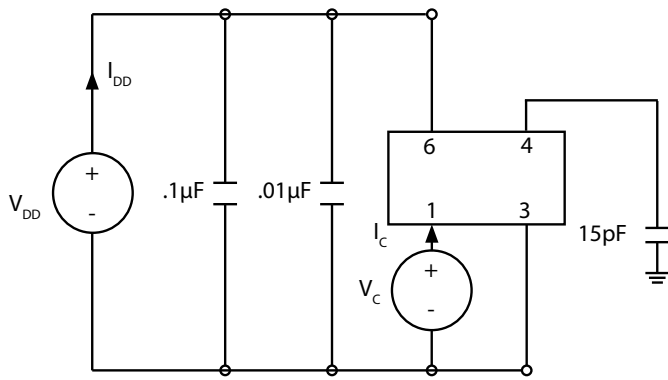
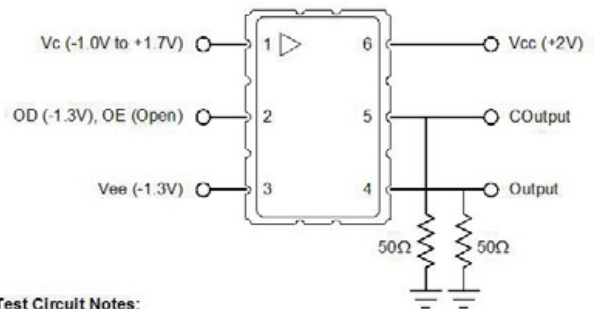

Figure 2. CMOS Test Circuit



Test Circuit Notes:
 1) To Permit 50Ω Measurement of Outputs, all DC Inputs are Biased Down 1.3V.
 2) All Voltage Sources Contain Bypass Capacitors to Minimize Supply Noise.
 3) 50Ω Terminations are Within Test Equipment.

Figure 3. LVPECL Test Circuit

Waveform

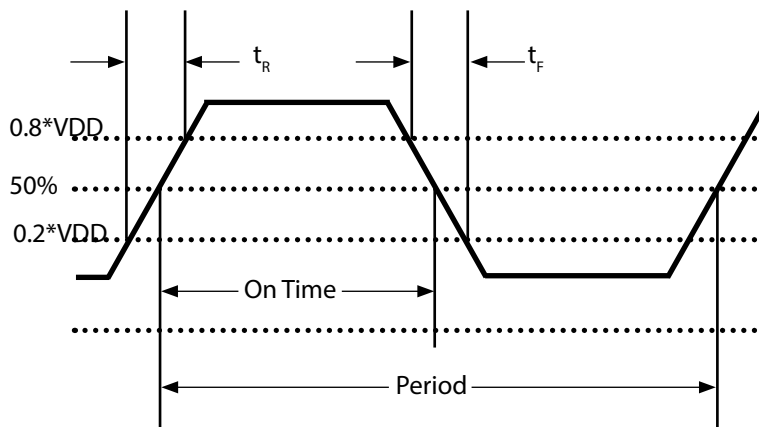

Figure 4. Output Waveform

Table 3. Absolute Maximum Ratings

Parameter	Symbol	Ratings	Unit
Power Supply	V_{DD}	0 to 6	V
Voltage Control Range	V_C	0 to V_{CC}	V
Storage Temperature	TS	-55 to 125	°C
Soldering Temp/Time	T_{LS}	260 / 20	°C / sec

Stresses in excess of the absolute maximum ratings can permanently damage the device. Functional operation is not implied at these or any other conditions in excess of conditions represented in the operational sections of this datasheet. Exposure to absolute maximum ratings for extended periods may adversely affect device reliability. Permanent damage is also possible if OD or Vc is applied before Vcc.

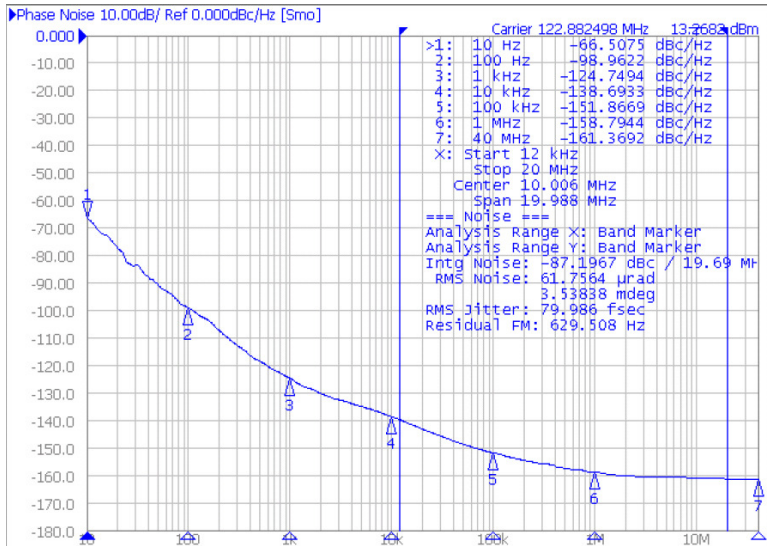

Figure 5A. Typical Phase Noise - 122.88 MHz CMOS

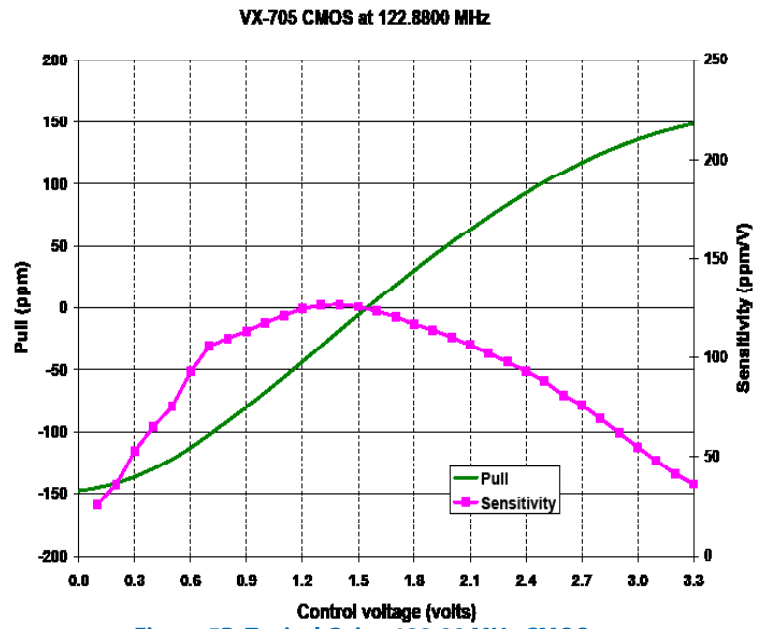

Figure 5B. Typical Gain - 122.88 MHz CMOS

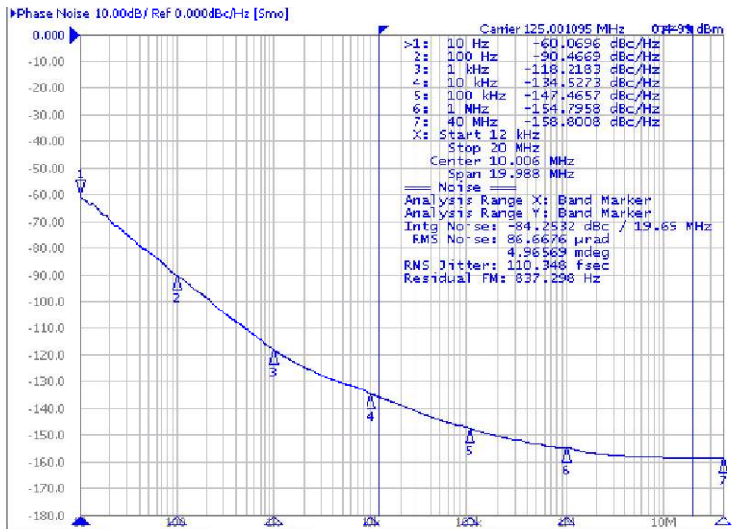

Figure 6A. Typical Phase Noise - 125.00 MHz PECL

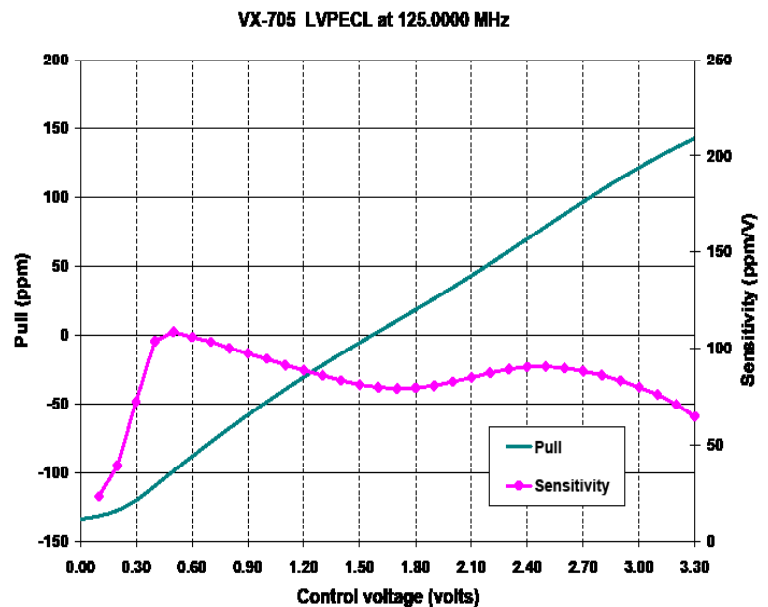

Figure 6B. Typical Gain - 125.00 MHz PECL

Reliability

VI qualification includes aging at various extreme temperatures, shock and vibration, temperature cycling, and IR reflow simulation. The VX-705 family is capable of meeting the following qualification tests:

Table 4. Environmental Compliance

Parameter	Conditions
Mechanical Shock	MIL-STD-883, Method 2002
Mechanical Vibration	MIL-STD-883, Method 2007
Solderability	MIL-STD-883, Method 2003
Gross and Fine Leak	MIL-STD-883, Method 1014
Resistance to Solvents	MIL-STD-883, Method 2015
Moisture Sensitivity Level	MSL 1
Contact Pads	Gold over Nickel

Handling Precautions

Although ESD protection circuitry has been designed into the VX-705 proper precautions should be taken when handling and mounting. VI employs a human body model (HBM) and a charged device model (CDM) for ESD susceptibility testing and design protection evaluation.

Table 5. ESD Ratings

Model	Minimum	Conditions
Human Body Model	500V	MIL-STD-883, Method 3015
Charged Device Model	500V	JESD22-C101

Table 6. Reflow Profile

Parameter	Symbol	Value
PreHeat Time	t_s	60 sec Min, 260 sec Max
Ramp Up	R_{UP}	3 °C/sec Max
Time Above 217 °C	t_L	60 sec Min, 150 sec Max
Time To Peak Temperature	T_{AMB-P}	480 sec Max
Time at 260 °C	t_p	30 sec Max
Ramp Down	R_{DN}	6 °C/sec Max

Solderprofile:

The device is qualified to meet the JEDEC standard for Pb-Free assembly. The temperatures and time intervals listed are based on the Pb-Free small body requirements. The VX-705 device is hermetically sealed so an aqueous wash is not an issue.

Termination Plating:
Electroless Gold Plate over Nickel Plate

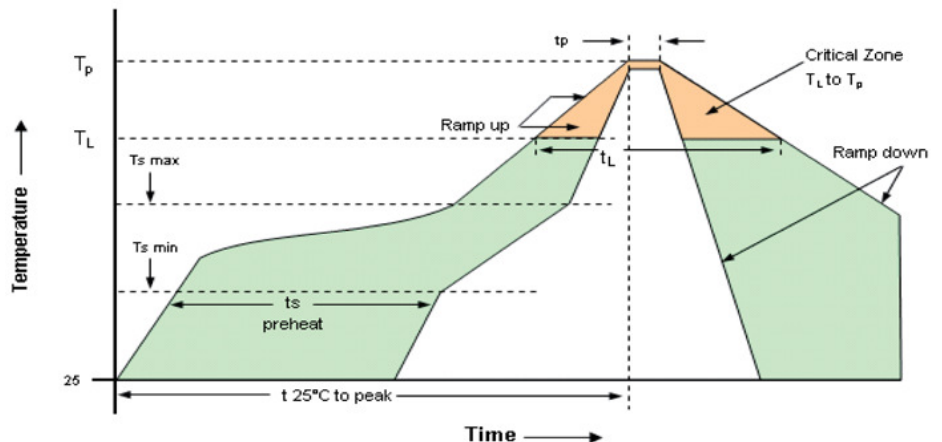

Figure 7. Recommended Reflow Profile

Outline Drawing & Pad Layout

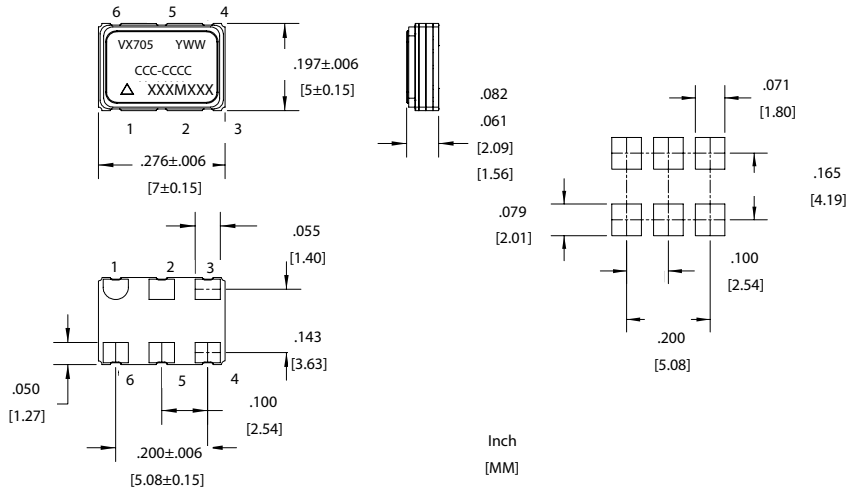

Figure 8. Outline Drawing and Pad Layout

Table 7a. Pin Out - 3.3V CMOS Option

Pin	Symbol	Function
1	V_C	VCXO Control Voltage
2	E/D	Enable Disable ** See Ordering Options**
3	GND	Case and Electrical Ground
4	Output	Output
5	N/C	No Connect
6	V_{DD}	Power Supply Voltage

Table 7b. Pin Out - 3.3V LVPECL Option

Pin	Symbol	Function
1	V_C	VCXO Control Voltage
2	E/D	Enable Disable **See Ordering Options**
3	GND	Case and Electrical Ground
4	Output	Output
5	COutput	Complementary Output
6	V_{DD}	Power Supply Voltage

Tape & Reel (EIA-481-2-A)

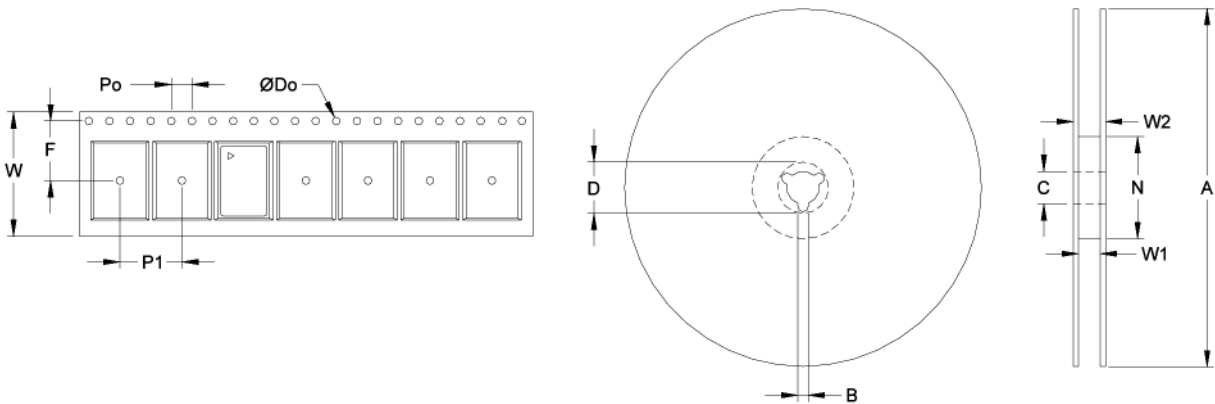

Figure 9. Tape and Reel Drawing

Table 8. Tape and Reel Information

Tape Dimensions (mm)						Reel Dimensions (mm)							
Dimension	W	F	Do	Po	P1	A	B	C	D	N	W1	W2	# Per Reel
Tolerance	Typ	Typ	Typ	Typ	Typ	Typ	Min	Typ	Min	Min	Typ	Max	
VX-705	16	5.5	1.5	4	8	178	1.78	13	20.6	55	12.4	22.4	500

Table 9. Standard Output Frequencies (MHz)

89.60000	96.00000	100.00000	120.00000	122.88000	125.00000	127.79520	148.50000
153.60000	155.52000	156.25000	161.13280				

Ordering Information

VX-705- E A T - K X A N- 122M880000

Product
VCXO, 5x7 Package

Voltage Options
E: +3.3 Vdc

Output
A: CMOS
C: LVPECL

Temp Range
T: 0/70°C
J: -20/70°C
E: -40/85°C

Frequency in MHz

Other (Future Use)
N: Standard

Enable/Disable

A: Enable High, Pin 2
C: Enable Low, Pin 2 (LVPECL)
X: No Enable Disable Feature, Pin 2
(No Connect Internally)

Stability

X: Standard
E: ±20 ppm Temperature

Absolute Pull Range

G: ±30 ppm
K: ±50 ppm

**Note: not all combination of options are available.
Other specifications may be available upon request.*

Example: VX-705-EAT-KXAN-122M880000

*** Add SNPBDIP for tin lead solder dip**

Example: VX-705-EAT-KXAN-122M880000_SNPBDIP



Microsemi, a wholly owned subsidiary of Microchip Technology Inc. (Nasdaq: MCHP), offers a comprehensive portfolio of semiconductor and system solutions for aerospace & defense, communications, data center and industrial markets. Products include high-performance and radiation-hardened analog mixed-signal integrated circuits, FPGAs, SoCs and ASICs; power management products; timing and synchronization devices and precise time solutions, setting the world's standard for time; voice processing devices; RF solutions; discrete components; enterprise storage and communication solutions, security technologies and scalable anti-tamper products. Ethernet solutions, Power-over-Ethernet ICs and midspans, as well as custom design capabilities and services. Learn more at www.microsemi.com

Microsemi Headquarters
One Enterprise, Aliso Viejo, CA 92656 USA
Within the USA: +1 (800) 713-4113
Outside the USA: +1 (949) 380-6100
Sales: +1 (949) 380-6136
Fax: +1 (949) 215-4996
email: sales.support@microsemi.com
www.microsemi.com

Microsemi makes no warranty, representation, or guarantee regarding the information contained herein or the suitability of its products and services for any particular purpose, nor does Microsemi assume any liability whatsoever arising out of the application or use of any product or circuit. The products sold hereunder and any other products sold by Microsemi have been subject to limited testing and should not be used in conjunction with mission-critical equipment or applications. Any performance specifications are believed to be reliable but are not verified, and Buyer must conduct and complete all performance and other testing of the products, alone and together with, or installed in, any end-products. Buyer shall not rely on any data and performance specifications or parameters provided by Microsemi. It is the Buyer's responsibility to independently determine suitability of any products and to test and verify the same. The information provided by Microsemi hereunder is provided 'as is, where is' and with all faults, and the entire risk associated with such information is entirely with the Buyer. Microsemi does not grant, explicitly or implicitly, to any party any patent rights, licenses, or any other IP rights, whether with regard to such information itself or anything described by such information. Information provided in this document is proprietary to Microsemi, and Microsemi reserves the right to make any changes to the information in this document or to any products and services at any time without notice.

©2019 Microsemi, a wholly owned subsidiary of Microchip Technology Inc. All rights reserved. Microsemi and the Microsemi logo are registered trademarks of Microsemi Corporation. All other trademarks and service marks are the property of their respective owners.