

ASL4500SHN

Four-phase boost converter

Rev. 6 — 26 October 2017

Product data sheet

1. Introduction

The ASL4500SHN is a highly integrated and flexible four-phase DC-to-DC boost converter IC. It has an SPI interface allowing control & diagnostic communication with an external microcontroller.

It is designed primarily for use in automotive LED lighting applications and provides an optimized supply voltage for ASLx41xSHN Multi-channel LED Buck Driver.

2. General description

The ASL4500SHN has a fixed frequency peak current mode control with parabolic/non-linear slope compensation. It can operate with input voltages from 5.5 V to 40 V. It can be configured via SPI for output voltages of up to 80 V, to power the LED buck driver IC.

The ASL4500SHN is a four-phase converter which can have two independent outputs. The driver has the flexibility to be configured, via the SPI interface, as a single output converter, or with multiple combinations of number of outputs & phases.

The ASL4500SHN boost converter can drive up to four external low-side N channel MOSFETs from an internally regulated adjustable supply. It can be used to drive either logic or standard level MOSFETs.

The integrated SPI interface also allows for programming the supply under/over voltage range, output voltage range and DC-to-DC switching frequency. It enables the optimization of external components and flexibility for EMC design. This interface can also be used to provide diagnostic information such as the driver temperature.

Additional features include protection against load dump transient voltages of up to 60 V and thermal shutdown when the junction temperature of the ASL4500SHN exceeds +175 °C.

The device is housed in a very small HVQFN32 pin package and is designed to meet the stringent requirements of automotive applications. It is fully AEC Q100 grade 1 qualified. It operates over the -40 °C to +125 °C ambient automotive temperature range.



3. Features and benefits

- The ASL4500SHN is an automotive grade product that is AEC-Q100 grade 1 qualified
- Operating ambient temperature range of -40 °C to +125 °C
- Wide operating input voltage range from +5.5 V to +40 V
- Output voltage programmable via SPI interface
- Multi-Phase Operation for higher power
- Up to four phases per output
- Up to two flexible output voltages with 3 % accuracy programmable via SPI
- Both output voltages can be controlled independently
- Fixed Frequency Operation via built-in oscillator
- Slope Compensation tracks the frequency and output voltage
- Programmable control loop compensation
- Fast high efficiency FET switching
- Programmable Internal Gate Driver Voltage Regulator
- Gate switching is halted when overvoltage on output is detected
- Supports both Logic Level and Standard Level FETs
- Low Electro Magnetic Emission (EME) and high Electro Magnetic Immunity (EMI)
- Output Voltage Monitoring
- Supply voltage measurement
- Control Signal to Enable the Device
- Read Back programmed voltage and frequency range via SPI
- Junction Temperature monitoring via SPI
- Small Package outline HVQFN32
- Low Quiescent current <5 μ A at 25 °C when EN = 0

4. Applications

- Automotive LED lighting
 - ◆ Low Beam
 - ◆ High beam
 - ◆ Daytime running lights
 - ◆ Turn indicator
 - ◆ Position or Park light
 - ◆ Front fog light
 - ◆ Cornering light

5. Ordering information

Table 1. Ordering information

Type number	Package		
	Name	Description	Version
ASL4500SHN	HVQFN32	plastic thermal enhanced very thin quad flat package; no leads; 32 terminals; body 5 × 5 × 0.85 mm	SOT617-12

6. Block diagram

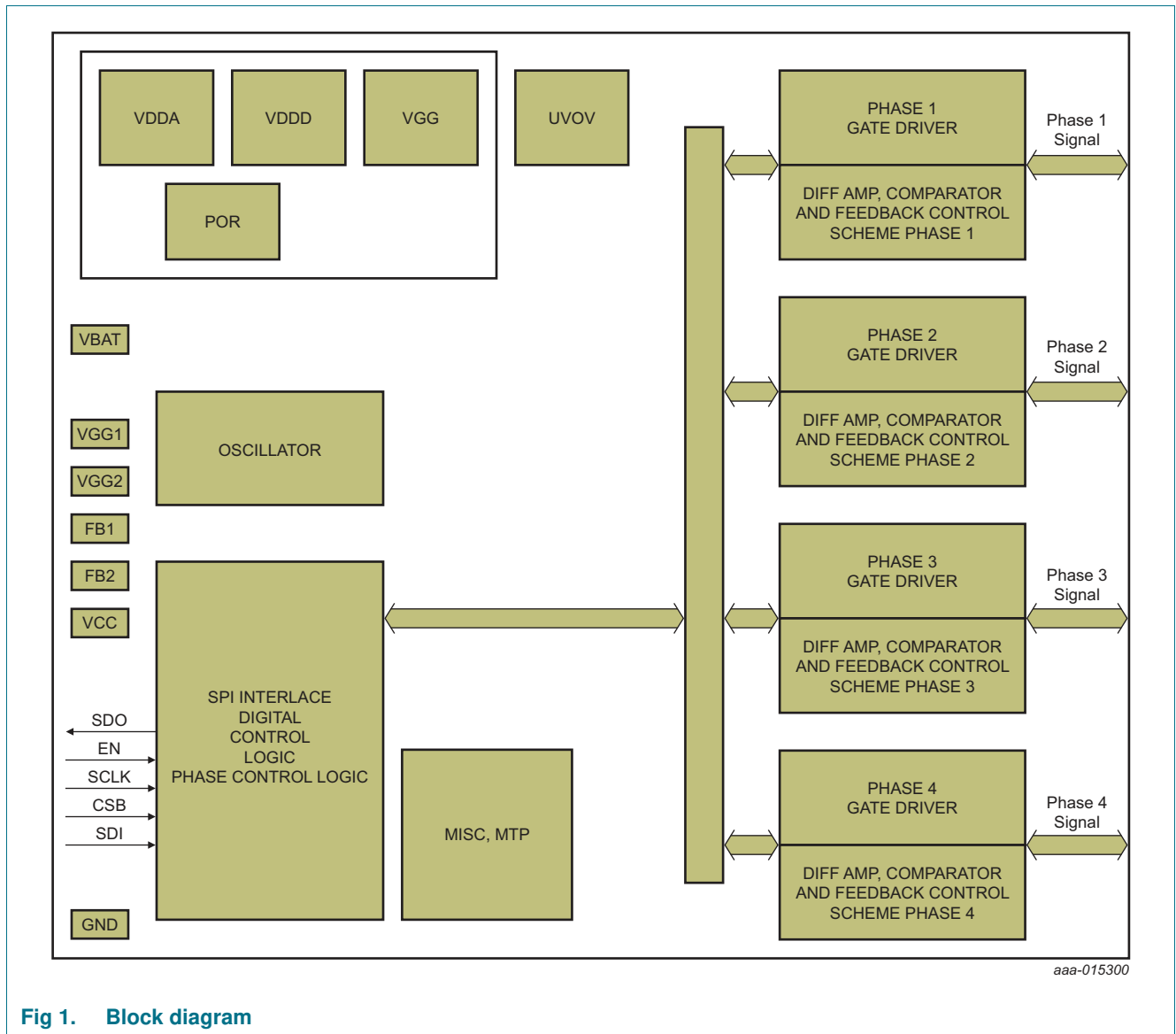
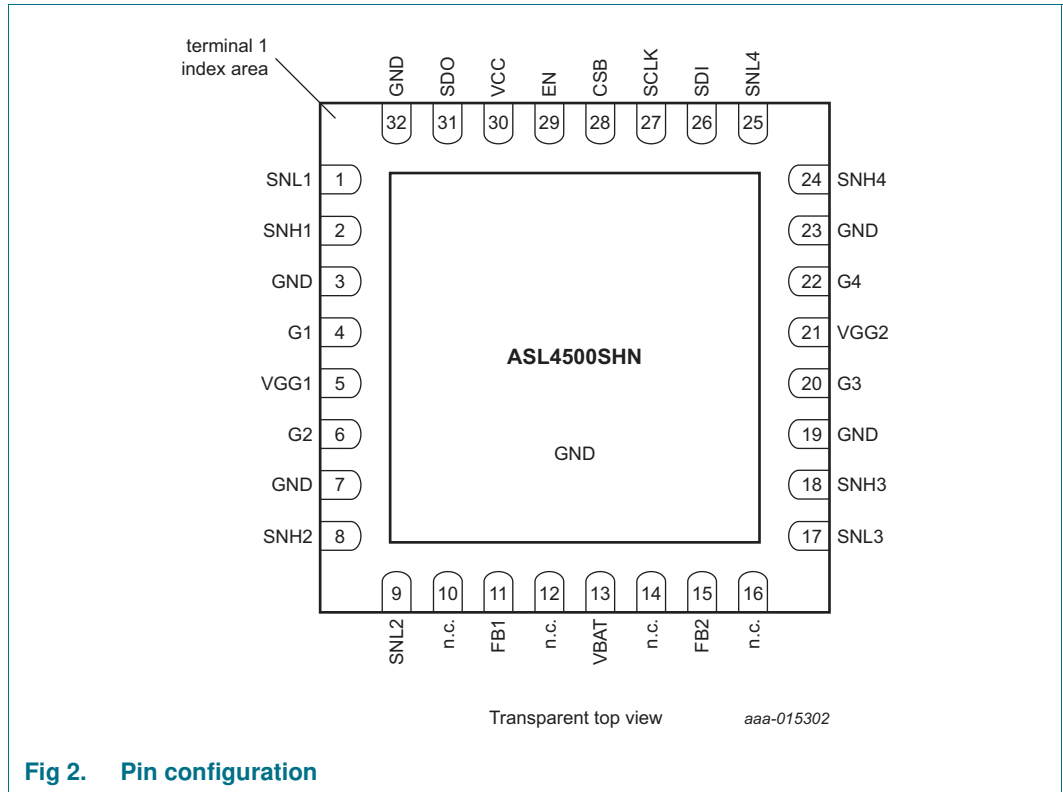

Fig 1. Block diagram

7. Pinning information

7.1 Pinning



7.2 Pin description

Table 2. Pin description [\[1\]](#)

Symbol	Pin	Description
SNL1	1	phase 1 sense low
SNH1	2	phase 1 sense high
GND	3	ground
G1	4	phase 1 gate driver
VGG1	5	gate driver supply 1 [2]
G2	6	phase 2 gate driver
GND	7	ground
SNH2	8	phase 2 sense high
SNL2	9	phase 2 sense low
n.c.	10	not connected
FB1	11	feedback; to be connected to Vout1 [3]
n.c.	12	not connected
VBAT	13	battery supply
n.c.	14	not connected

Table 2. Pin description ...continued^[1]

Symbol	Pin	Description
FB2	15	feedback; to be connected to Vout2 ^[3]
n.c.	16	not connected
SNL3	17	phase 3 sense low
SNH3	18	phase 3 sense high
GND	19	ground
G3	20	phase 3 gate driver
VGG2	21	gate driver supply 2 ^[2]
G4	22	phase 4 gate driver
GND	23	ground
SNH4	24	phase 4 sense high
SNL4	25	phase 4 sense low
SDI	26	SPI data input
SCLK	27	SPI clock
CSB	28	SPI chip select
EN	29	enable signal
VCC	30	external 5 V supply
SDO	31	SPI data out
GND	32	chip ground

[1] For enhanced thermal and electrical performance, the exposed center pad of the package should be soldered to board ground (and not to any other voltage level).

[2] VGG1 and VGG2 are connected internally.

[3] Refer to [Figure 4](#) and [Figure 14](#) for the recommended connections for pin FB1 and pin FB2.

8. Functional description

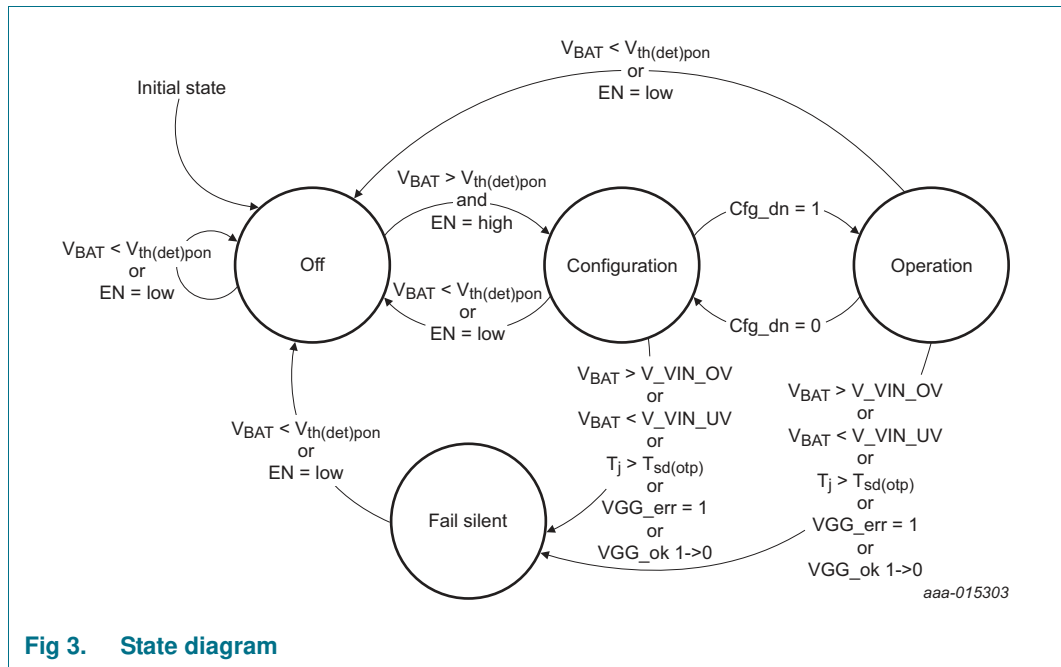

Fig 3. State diagram

8.1 Operating modes

Table 3. Operating modes

Mode	Control registers	Configuration registers	Diagnostic registers	VGG	Vout1 Vout2	Remarks
Off	n.a.	n.a.	n.a.	off	off	device is off, no communication possible.
Configuration	read/write	read/write	read	off	off	VGG is off if no outputs were previously enabled
			read	according to register	off	VGG is on as soon as one of the outputs has been enabled
Operation	read/write	read	read	locked	according to register	configuration registers are locked
Fail silent	read/write	read	read ^[1]	off	off	communication possible, but all outputs off. Restart via EN possible.

[1] Setting the bit `cfg_dn` to 0 also grants write access to the configuration registers.

8.1.1 Off mode

The ASL4500SHN switches to off mode, if the input voltage drops below the power-on detection threshold ($V_{th(det)pon}$) or the EN pin is low.

In Off mode, the SPI interface and all outputs are turned off.

8.1.2 Configuration mode

The ASL4500SHN switches immediately from Off mode to Configuration mode, when the input voltage rises above the power-on detection threshold ($V_{th(det)pon}$) and pin EN is high.

The configuration registers can be set when the ASL4500SHN is in the Configuration mode.

8.1.3 Operation mode

The ASL4500SHN switches from configuration mode to operation mode, as soon as the configuration done bit is set. Once the bit is set, the configuration registers are locked and cannot be changed.

In operation mode, the output is available as configured via the SPI interface. Setting bits Vout1en or Vout2en, initiates the gate driver. Once the gate driver is in regulation, signaled by bit VGG_ok, the respective programmed target voltages are turned on. When the converters are on, the battery monitoring functionality is available.

8.1.4 Fail silent mode

The ASL4500SHN switches from Operation mode to Fail silent mode, when the junction temperature exceeds the over temperature shutdown threshold or a gate driver error is detected. It will also switch modes when the input voltage is below the under voltage detection threshold or above the over voltage detection threshold.

In Fail silent mode, all outputs are turned off and only the SPI interface remains operational.

8.2 Boost converter configuration

The ASL4500SHN is an automatic boost converter IC delivering constant DC-to-DC voltage to a load. It has a fixed frequency current-mode control for an enhanced stable operation.

The ASL4500SHN offers four phases. Each phase consists of a coil, a resistor, a MOSFET and a diode as shown in [Figure 4](#).

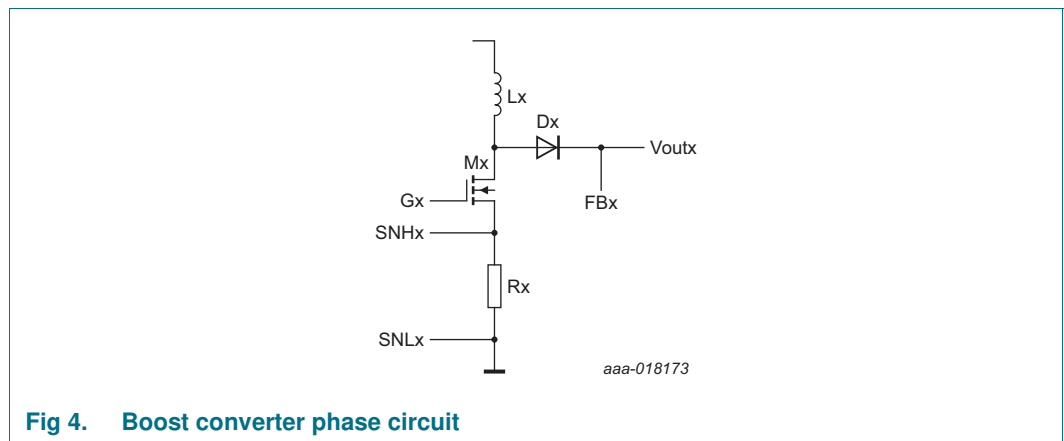

Fig 4. Boost converter phase circuit

To allow flexible use of the ASL4500SHN, the configuration is based on virtual phases. They are then mapped to a real physical phase according to the physical connections and conditions of the circuitry around the ASL4500SHN as shown in [Figure 5](#).

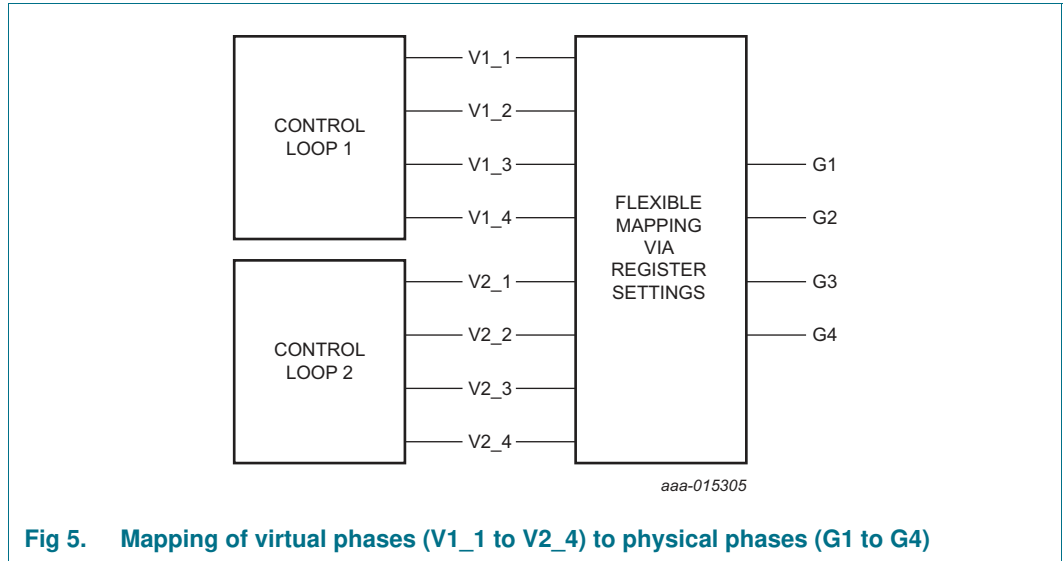

Fig 5. Mapping of virtual phases (V1_1 to V2_4) to physical phases (G1 to G4)

8.2.1 Virtual phase configuration

The ASL4500SHN can generate up to four internal phases at up to two virtual outputs. With the internal phase control enable registers, it can be selected, how many virtual phases are generated for the individual virtual outputs.

Table 4. Internal phase control enable for output 1 (address 0x0Bh)

Bit	Symbol	Description	Value	Function
7:4	-	reserved	0000	reserved for future use: keep clear
3	EN_P4_1	phase 4 enabled	0	phase 4 is off
			1	phase 4 is enabled
2	EN_P3_1	phase 3 enabled	0	phase 3 is off
			1	phase 3 is enabled
1	EN_P2_1	phase 2 enabled	0	phase 2 is off
			1	phase 2 is enabled
0	EN_P1_1	phase 1 enabled	0	phase 1 is off
			1	phase 1 is enabled

Table 5. Internal phase control enable for output 2 (address 0x0Ch)

Bit	Symbol	Description	Value	Function
7:4	-	reserved	0000	reserved for future use: keep clear
3	EN_P4_2	Phase 4 enabled	0	phase 4 is off
			1	phase 4 is enabled
2	EN_P3_2	Phase 3 enabled	0	phase 3 is off
			1	phase 3 is enabled
1	EN_P2_2	Phase 2 enabled	0	phase 2 is off
			1	phase 2 is enabled
0	EN_P1_2	Phase 1 enabled	0	phase 1 is off
			1	phase 1 is enabled

8.2.2 Association of physical phases to the output voltages

The phase that the ASL4500SHN offers, must be associated to the output.

Table 6. Gate driver output (address 0x02h)

Bit	Symbol	Description	Value	Function
7:4	-	reserved	0000	reserved for future use: keep clear
3	O_G4	association phase 4	0	phase 4 is connected to $V_{out 1}$
			1	phase 4 is connected to $V_{out 2}$
2	O_G3	association phase 3	0	phase 3 is connected to $V_{out 1}$
			1	phase 3 is connected to $V_{out 2}$
1	O_G2	association phase 2	0	phase 2 is connected to $V_{out 1}$
			1	phase 2 is connected to $V_{out 2}$
0	O_G1	association phase 1	0	phase 1 is connected to $V_{out 1}$
			1	phase 1 is connected to $V_{out 2}$

8.2.3 Association of connected phases to the internal phase generation

Each physical phase that the ASL4500SHN offers, must be associated to one of the virtual phases of the output. It is established with the gate driver phase and phase select configuration registers.

Table 7. Gate driver phase, address (address 0x0Fh)

Bit	Symbol	Description	Value	Function
7:4	-	reserved	0000	reserved for future use: keep clear
3	O_GP4	association phase 4	0	phase 4 is connected to $V_{out 1}$
			1	phase 4 is connected to $V_{out 2}$
2	O_GP3	association phase 3	0	phase 3 is connected to $V_{out 1}$
			1	phase 3 is connected to $V_{out 2}$
1	O_GP2	association phase 2	0	phase 2 is connected to $V_{out 1}$
			1	phase 2 is connected to $V_{out 2}$
0	O_GP1	association phase 1	0	phase 1 is connected to $V_{out 1}$
			1	phase 1 is connected to $V_{out 2}$

Table 8. Gate driver phase, address (address 0x0Fh)

Bit	Symbol	Description	Value	Function
7:6	Phsel4[1:0]	phase select gate driver 4	0x0h	routing from phase 1
			0x1h	routing from phase 2
			0x2h	routing from phase 3
			0x3h	routing from phase 4
5:4	Phsel3[1:0]	phase select gate driver 3	0x0h	routing from phase 1
			0x1h	routing from phase 2
			0x2h	routing from phase 3
			0x3h	routing from phase 4
3:2	Phsel2[1:0]	phase select gate driver 2	0x0h	routing from phase 1
			0x1h	routing from phase 2
			0x2h	routing from phase 3
			0x3h	routing from phase 4
1:0	Phsel1[1:0]	phase select gate driver 1	0x0h	routing from phase 1
			0x1h	routing from phase 2
			0x2h	routing from phase 3
			0x3h	routing from phase 4

8.2.4 Enabling of connected phases

The gate driver enable register is used to configure which of the phases is active.

Table 9. Gate driver enable (address 0x01h)

Bit	Symbol	Description	Value	Function
7:4	-	reserved	0000	reserved for future use: keep clear
3	EN_G4	phase 4 enabled	0	phase 4 is off
			1	phase 4 is enabled
2	EN_G3	phase 3 enabled	0	phase 3 is off
			1	phase 3 is enabled
1	EN_G2	phase 2 enabled	0	phase 2 is off
			1	phase 2 is enabled
0	EN_G1	phase 1 enabled	0	phase 1 is off
			1	phase 1 is enabled

8.2.5 Boost converter frequencies configuration

The operation frequency of the boost converters can be set with via several SPI registers. To ensure a stable phase delay between the different phases, all timings are derived from the same oscillator. An integer number downscales the internal oscillator frequency for each regulation loop. This slower clock is then used to control the off time of a phase. It also controls the delay from one phase of the regulation loop to the next internal phase. The number of phases determinates finally when the phase is turned on again and defines so the operation frequency of the boost converter.

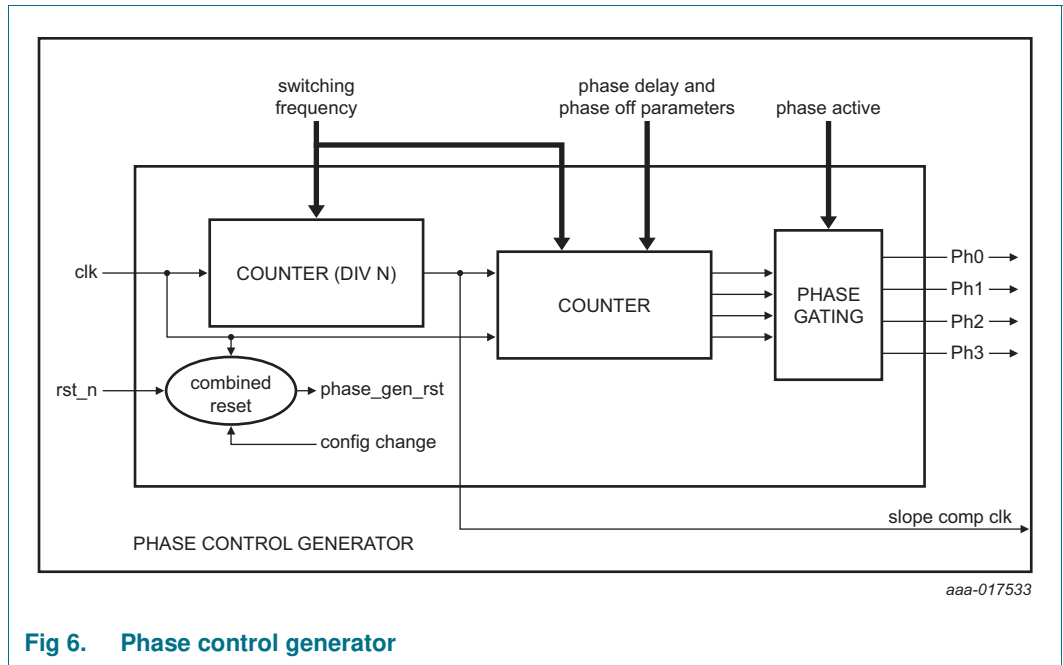

Fig 6. Phase control generator

Table 10. Clock divider for Vout1 (address 0x09h)

Bit	Symbol	Description	Value	Function
7:0	Clkdiv1[7:0]	clock divider for output voltage 1	0x00h	clock is not divided
			...	clock is divided by Clkdiv1[7:0] + 1
			0xFFh	clock is divided by 256

Table 11. Clock divider for Vout2 (address 0x0Ah)

Bit	Symbol	Description	Value	Function
7:0	Clkdiv2[7:0]	clock divider for output voltage 2	0x00h	clock is not divided
			...	clock is divided by Clkdiv2[7:0] + 1
			0xFFh	clock is divided by 256

Table 12. Phase-off time and phase delay of output 1 (address 0x0Dh)

Bit	Symbol	Description	Value	Function
7:3	Phdel1[4:0]	delay to next phase of output 1	0x0h	phase delay is 1 clock period of the divided clock
			...	phase delay is Phdel1[4:0] + 1 clock period of the divided clock
			0x1Fh	phase delay is 32 clock periods of the divided clock
2:0	Phoff1[2:0]	phase-off time of output 1	0x0h	phase-off time is 1 clock period of the divided clock
			...	phase-off time is Phoff1[2:0] clock period of the divided clock
			0x7h	phase-off time is 7 clock periods of the divided clock

Table 13. Phase-off time and phase delay of output 2 (address 0x0Eh)

Bit	Symbol	Description	Value	Function
7:3	Phdel2[4:0]	delay to next phase of output 2	0x0h	phase delay is 1 clock period of the divided clock
			...	phase delay is Phdel2[4:0] + 1 clock period of the divided clock
			0x1Fh	phase delay is 32 clock periods of the divided clock
2:0	Phoff2[2:0]	phase-off time of output 2	0x0h	phase-off time is 1 clock period of the divided clock
			...	phase-off time is Phoff2[2:0] clock period of the divided clock
			0x7h	phase-off time is 7 clock periods of the divided clock

Note: To obtain the best performance of the internal slope compensation, keep the settings of the delay between the phases as close to 32 as possible.

8.2.6 Control loop parameter settings

The ASL4500SHN is able to operate with a wide range of external components and offers a wide range of operating frequencies. To achieve maximum performance for each set of operation conditions, set the control loop parameters in accordance with the external components and operating frequency.

Table 14. Loop filter proportional configuration (address 0x11h)

Bit	Symbol	Description	Value	Function
7:4	Prop2[3:0]	proportional factor output 2	0x0h	proportional factor output 2 is 0.05
			...	proportional factor output 2 is Prop2[3:0]*0.05+0.05
			0xFh	proportional factor output 2 is 0.8
3:0	Prop1[3:0]	proportional factor output 1	0x0h	proportional factor output 1 is 0.05
			...	proportional factor output 1 is Prop1[3:0]*0.05+0.05
			0xFh	proportional factor output 1 is 0.8

Table 15. Loop filter integral configuration (address 0x12h)

Bit	Symbol	Description	Value	Function
7:4	Integ2[3:0]	integral factor output 2	0x0h	integral factor output 2 is 0.005
			...	integral factor output 2 is Integ2[3:0]*0.005+0.005
			0xFh	integral factor output 2 is 0.08
3:0	Integ1[3:0]	integral factor output 1	0x0h	integral factor output 1 is 0.005
			...	integral factor output 1 is Integ1[3:0]*0.005+0.005
			0xFh	integral factor output 1 is 0.08

Table 16. Slope compensation configuration (address 0x13h)

Bit	Symbol	Description	Value	Function
7:4	Slpcmp2[3:0]	slope compensation factor output 2	0x0h	slope compensation factor output 2 = 112 k Ω
			0x1h	slope compensation factor output 2 = 84 k Ω
			0x2h	slope compensation factor output 2 = 70 k Ω
			0x4h	slope compensation factor output 2 = 56 k Ω
			0x8h	slope compensation factor output 2 = 28 k Ω
3:0	Slpcmp1[3:0]	slope compensation factor output 1	0x0h	slope compensation factor output 1 = 112 k Ω
			0x1h	slope compensation factor output 1 = 84 k Ω
			0x2h	slope compensation factor output 1 = 70 k Ω
			0x4h	slope compensation factor output 1 = 56 k Ω
			0x8h	slope compensation factor output 1 = 28 k Ω

Table 17. Current sense slope resistor configuration (address 0x14h)

Bit	Symbol	Description	Value	Function
7:6	Slpr4[1:0]	slope resistor configuration for gate driver 4	0x0h	2'b00 - 250 Ω
			0x1h	2'b01 - 500 Ω
			0x2h	2'b10 - 1000 Ω
			0x3h	2'b11 - 1500 Ω
5:4	Slpr3[1:0]	slope resistor configuration for gate driver 3	0x0h	2'b00 - 250 Ω
			0x1h	2'b01 - 500 Ω
			0x2h	2'b10 - 1000 Ω
			0x3h	2'b11 - 1500 Ω
3:2	Slpr2[1:0]	slope resistor configuration for gate driver 2	0x0h	2'b00 - 250 Ω
			0x1h	2'b01 - 500 Ω
			0x2h	2'b10 - 1000 Ω
			0x3h	2'b11 - 1500 Ω
1:0	Slpr1[1:0]	slope resistor configuration for gate driver 1	0x0h	2'b00 - 250 Ω
			0x1h	2'b01 - 500 Ω
			0x2h	2'b10 - 1000 Ω
			0x3h	2'b11 - 1500 Ω

8.3 Output voltage programmability

The ASL4500SHN provides the possibility to program the output voltage and output overvoltage protection of the output via the SPI interface.

8.3.1 Output voltage target programmability

The target output voltage can be programmed via the Output voltage registers. As the ASL4500SHN is a boost converter, the output voltage cannot be lower than the supply voltage minus the drop of the converter diode (Dx in [Figure 4](#)).

Table 18. Output voltage 1 register (address 0x03h)

Bit	Symbol	Description	Value	Function
7:0	V_Vout_1[7:0]	target voltage output 1	0x00h	output 1 is turned off
			...	target voltage output 1 = $0.3555 * V_Vout_1 [7:0] * (1 + (333e-6) * (T_junction[7:0] - 38))$
			0xFFh	maximum target output voltage = 90 V

Table 19. Output voltage 2 register (address 0x04h)

Bit	Symbol	Description	Value	Function
7:0	V_Vout_2[7:0]	target voltage output 2	0x00h	output 2 is turned off
			...	target voltage output 2 = $0.3555 * V_Vout_2 [7:0] * (1 + (333e-6) * (T_junction[7:0] - 38))$
			0xFFh	maximum target output voltage = 90 V

8.3.2 Output overvoltage protection programming

Due to fast changes in the supply or the output, it is possible that the output voltage is disturbed. To avoid high voltages that may result into damage of attached components, the ASL4500SHN offers a programmable overvoltage protection threshold. Once the output voltage is above this threshold, the gate pin of the output stops toggling. It results in a halt of the energy delivery to the output.

Once the output voltage recovers and is below the threshold again, the gate pin starts toggling again. The regulation loop regulates the output back to the target value.

For stable operation of the device, the limit voltage output register should be programmed around 5 V higher than the output voltage registers.

Table 20. Limit voltage output 1 register (address 0x05h)

Bit	Symbol	Description	Value	Function
7:0	Vmax_Vout_1[7:0]	limit output 1	0x00h	output 1 is turned off
			...	output overvoltage protection output 1 = $0.3555 * V_Vout_1 [7:0] * (1 + (333e-6) * (T_junction[7:0] - 38))$
			0xFFh	maximum output over voltage protection output 1 = 90 V

Table 21. Limit voltage output 2 register (address 0x06h)

Bit	Symbol	Description	Value	Function
7:0	Vmax_Vout_2[7:0]	limit output 2	0x00h	output 2 is turned off
			...	output overvoltage protection output 2 = $0.3555 * V_Vout_2 [7:0] * (1 + (333e-6) * (T_junction[7:0] - 38))$
			0xFFh	maximum output over voltage protection output 2 = 90 V

8.4 Coil peak current limitation

The ASL4500SHN offers a function to limit peak current inside the coil and therefore to limit the input current for the system. Furthermore, this functionality can be used to avoid magnetic saturation of the coils and allow some soft start feature to be realized.

With the maximum phase current Voutx registers, the maximum peak current for the individual phases assigned to the output can be configured. Once the voltage drop between pins SNLx and SNHx reaches this level, the gate will be turned off until the next switching cycle. To avoid sub harmonic oscillations when the coil peak current limitation is becoming active, the slope compensation is still active. It reduces the coil peak current towards the end of the switching cycle to ensure stable operation of the system.

To avoid that this function interferes with the normal regulation, the limit should be placed well above the maximum expected currents.

Table 22. Maximum phase current Vout1 register (address 0x07h)

Bit	Symbol	Description	Value	Function
7:0	I_max_per_phase_Vout1 [7:0]	coil current limitation for phases assigned to Vout1	0x00h	no current allowed
			...	maximum peak current = $(I_{\text{max_per_phase_Vout1}} [7:0] * 1.8 \text{ V} / 256 - 0.24 \text{ V}) / R_{\text{sense}}$
			0x80h	maximum allowed setting = $(128 / 256 * 1.8 \text{ V} - 0.24 \text{ V}) / R_{\text{sense}}$
			...	not allowed
			0xFFh	not allowed

Table 23. Maximum phase current Vout2 register (address 0x08h)

Bit	Symbol	Description	Value	Function
7:0	I_max_per_phase_Vout2 [7:0]	coil current limitation for phases assigned to Vout2	0x00h	no current allowed
			...	maximum peak current = $(I_{\text{max_per_phase_Vout2}} [7:0] * 1.8 \text{ V} / 256 - 0.24 \text{ V}) / R_{\text{sense}}$
			0x80h	maximum allowed setting = $(128/256*1,8 \text{ V} - 0.24 \text{ V}) / R_{\text{sense}}$
			...	not allowed
			0xFFh	not allowed

8.5 Enabling output voltage

The ASL4500SHN provides two independent output voltages. In operation mode, the output voltages are turned on with the bits Vout1en and Vout2en.

As soon as one of the outputs is turned on, the gate driver voltage regulator is turned on. After the gate driver start-up time, the gate drivers start switching if the bit VGG_ok is set.

Table 24. Function control register (address 0x00h)

Bit	Symbol	Description	Value	Function
7:4	-	reserved	0000	reserved: keep clear for future use
3	Cnt_CSB	count chip select time	0	chip select low count feature is disabled
			1	chip select low count feature is enabled
2	Vout2en	enable output 2	0	output 2 is turned off
			1	output 2 is turned on, when the device is in operation mode
1	Vout1en	enable output 1	0	output 1 is turned off
			1	output 1 is turned on, when the device is in operation mode
0	Cfg_dn	configuration done	0	device is in configuration mode - no configuration lock
			1	device is in configuration mode - configuration lock is active

8.6 Frequency trimming

It is mandatory to adjust the internal oscillator frequency of the device to ensure the ASL4500SHN is operating within the specified oscillator frequency range.

To measure the actual internal frequency, the device measures the time that the CSB pin is low during an SPI transfer. This time information is used to adjust the oscillator frequency of the device. The recommended procedure for the time adjustment is shown in [Figure 7](#).

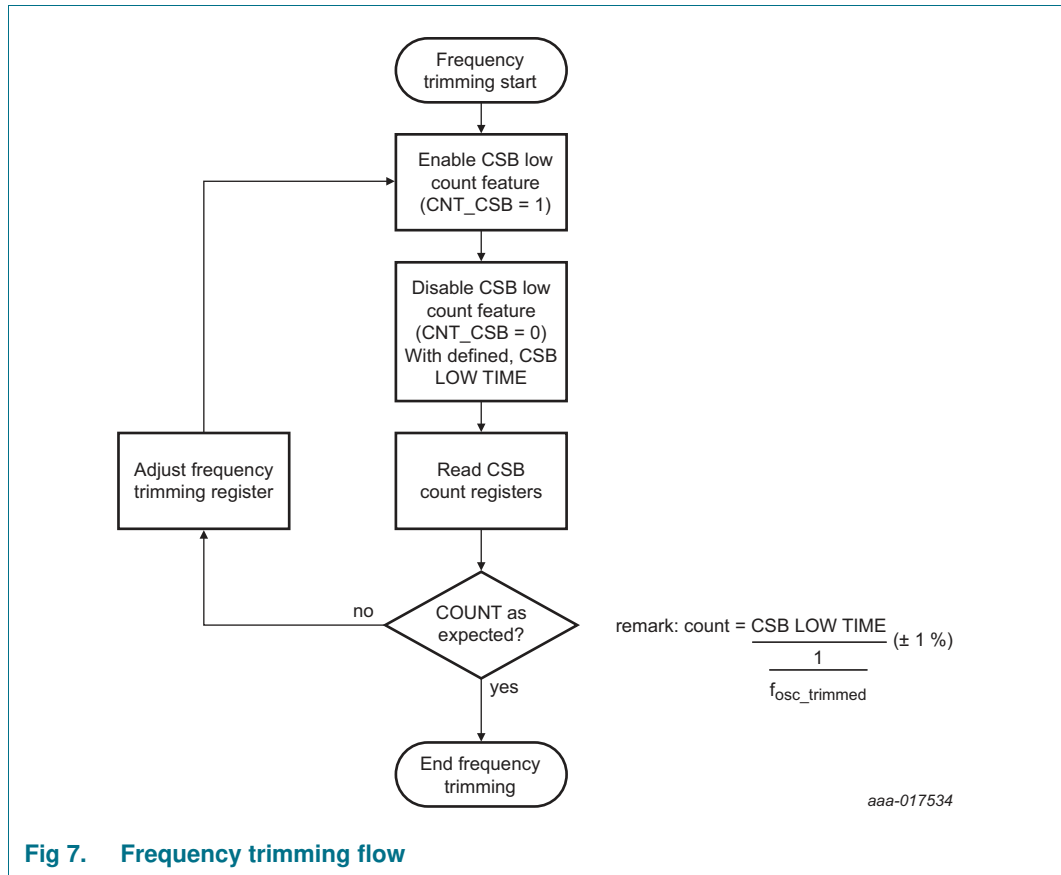

Fig 7. Frequency trimming flow

At the start of the sequence, the CSB low count feature is activated. It is done by setting the Cnt_CSB bit high in the frequency trimming control register (bit 3; register 0x00h). The device now measures the time with its internal time domain each time the CSB pin is low. It makes this information available in the CSB count registers. To allow an exact stable reading, set the Cnt_CSB bit low again with an accurately known CSB low time. Setting the bit low freezes the count registers. These registers store the last value, which in this case is the command that sets the Cnt_CSB bit low.

The CSB count registers contain the count of the CSB low time of the last SPI command the CSB low count feature was enabled. CSB count register 1 contains the bits 7 to 0 of the counter, while the CSB count register 2 contains the bits 15:8.

Table 25. CSB count register 1 (address 0x041h)

Bit	Symbol	Description	Value	Function
7:0	CSB_cnt[7:0]	CSB count low	...	count value (bits 7:0)

Table 26. CSB count register 2 (address 0x042h)

Bit	Symbol	Description	Value	Function
15:8	CSB_cnt[15:8]	CSB count high	...	count value (bits 15:8)

The count, the CSB count register returns, should correspond to the real time of the CSB low time. 1 count should correspond with $1/f_{\text{osc_trimmed}}$ (see Table 44).

When the CSB count register count, deviates from the applied CSB low time, adjust the device internal timing by modifying the frequency trimming register.

Table 27. Frequency trimming register (address 0x1Ch)

Bit	Symbol	Description	Value	Function
7:6	-	reserved	-	n.a.
5:0	Freq_trim[5:0]	frequency trim bits	010001	default frequency – 33.33 %
			010011	default frequency – 30.56 %
			010101	default frequency – 27.78 %
			010111	default frequency – 25.00 %
			011001	default frequency – 22.22 %
			011011	default frequency – 19.44 %
			011101	default frequency – 16.67 %
			011111	default frequency – 13.89 %
			000001	default frequency – 11.11 %
			000011	default frequency – 8.33 %
			000101	default frequency – 5.56 %
			000111	default frequency – 2.78 %
			001001	default frequency
			001011	default frequency + 2.78 %
			001101	default frequency + 5.56 %
			001111	default frequency + 8.33 %
			110001	default frequency + 11.11 %
			110011	default frequency + 13.89 %
			110101	default frequency + 16.67 %
			110111	default frequency + 19.44 %
111001	default frequency + 22.22 %			
111011	default frequency + 25.00 %			
111101	default frequency + 27.78 %			
111111	default frequency + 30.56 %			
100001	default frequency + 33.33 %			
100011	default frequency + 36.11 %			
		others		not allowed

To ensure that the adjustment had the desired effect, restart the procedure and check the count with the new settings in the frequency trimming register.

When the device internal time matches the applied CSB low time, no further adjustment is needed and the trimming procedure is finished.

8.7 Gate supply voltage

The ASL4500SHN has an integrated linear regulator to generate the supply voltage of the gate drivers. The integrated linear regulator is internally connected to the pins VGG1 and VGG2. The voltage generated by the linear regulator can be set via the VGG control register.

Table 28. VGG control register (address 0x15h)

Bit	Symbol	Description	Value	Function
7:0	VGG[7:0]	supply voltage for gate drivers	0x00h	not allowed
			...	not allowed
			0x5Dh	maximum output voltage = 10.04 V
			...	$(255 - \text{VGG}[7:0]) * 62 \text{ mV}$
			0xB7h	minimum output voltage = 4.46 V
			...	not allowed
			0xFFh	not allowed

The actual value of VGG can deviate from the target setting due to the tolerances of the VGG regulation loop (see $V_{o(\text{reg})\text{acc}}$ in [Table 43](#)).

When a setting between 0x00h and 0x5Dh is used, the resulting gate driver target voltage exceeds the limiting values of the IC. The limiting values of the VGG pin can also be violated with target settings of 0xA6h to 0x5Dh due to these tolerances. A violation of the limiting values with the actual VGG voltage must be avoided. To ensure that only allowed settings are used for the gate driver target voltage, an immediate read back of the programmed value is required after setting the registers.

If a setting between 0xFFh and 0xB7h is used, the device may not start up VGG. If the device operates, parameters of VGG are not guaranteed.

8.7.1 Gate voltage supply diagnostics

The diagnostic options for the gate voltage supply are:

- gate driver available. Details can be found in [Section 8.10](#)
- gate driver protection active. Details can be found in [Section 8.10](#)

8.8 Supply voltage monitoring

When at least one of the outputs is enabled and bit VGG_ok is set, the ASL4500SHN continuously measures the voltage at pin VBAT. It allows the system to monitor the supply voltage without additional external components. It also offers the option to put an automatic undervoltage or overvoltage protection in place.

Note: The VIN_UV and VIN_OV bits in the status register use the battery voltage measurement. As a result, the VIN_UV and VIN_OV bits are only reliable when at least one output is enabled.

8.8.1 Battery voltage measurement

The ASL4500SHN continuously measures the voltage at pin VBAT. The measurement result is available in the battery voltage register when at least one output is enabled.

Table 29. Battery voltage register (address 0x045h)

Bit	Symbol	Description	Value	Function
7:0	V_VBAT[7:0]	battery voltage	0x00h	battery voltage = 0 V
			...	battery voltage = $0.3555 * V_VBAT [7:0] * (1 + 333e-6 * (T_junction[7:0] - 38))$
			0xFFh	maximum measurable battery voltage = 90 V

8.8.2 Undervoltage detection

The ASL4500SHN offers a variable undervoltage detection threshold. When the supply voltage drops below this threshold, the undervoltage detect bit is set, and Fail silent mode is entered. All gate pins stop toggling and power is no longer delivered to the output.

Table 30. Undervoltage threshold register (address 0x01Bh)

Bit	Symbol	Description	Value	Function
7:0	V_VIN_UV[7:0]	undervoltage detection threshold	0x00h	undervoltage detection threshold = 0 V
			...	under voltage detection threshold = $0.3555 * V_VIN_UV [7:0] * (1 + 333e-6 * (T_junction[7:0] - 38))$
			0xFFh	maximum under voltage detection threshold = 90 V

8.8.3 Overvoltage detection

The ASL4500SHN offers a variable overvoltage detection threshold. When the supply voltage rises above this threshold, the overvoltage detect bit is set, and Fail silent mode is entered. All gate pins stop toggling and power is no longer delivered to the output.

Table 31. Overvoltage threshold register (address 0x01Ah)

Bit	Symbol	Description	Value	Function
7:0	V_VIN_OV[7:0]	overvoltage detection threshold	0x00h	overvoltage detection threshold = 0 V
			...	overvoltage detection threshold = $0.3555 * V_VIN_OV [7:0] * (1 + 333e-6 * (T_junction[7:0] - 38))$
			0xFFh	maximum overvoltage detection threshold = 90 V

8.9 Junction temperature information

The ASL4500SHN provides a measurement of the IC junction temperature. The measurement information is available in the junction temperature register.

Table 32. Junction temperature register (address 0x046h)

Bit	Symbol	Description	Value	Function
7:0	T_junction [7:0]	junction temperature	...	device junction temperature below $-40\text{ }^{\circ}\text{C}$
			0x18h	device junction temperature = $-40\text{ }^{\circ}\text{C}$
			...	device junction temperature = $T_junction[7:0] * (215/106)\text{ }^{\circ}\text{C} - 88\text{ }^{\circ}\text{C}$
			0x82h	device junction temperature = $175\text{ }^{\circ}\text{C}$
			0x82h	device junction temperature above $175\text{ }^{\circ}\text{C}$

8.10 Diagnostic information

The diagnostic register contains useful information for diagnostic purposes. Details for each bit can be found in the following subchapters.

Table 33. Diagnostic register (address 0x05Fh)

Bit	Symbol	Description	Value	Function
7	Vout1_ok	Vout1 regulated	0	Vout1 is deviating from the target value
			1	Vout1 is regulated to the target value
6	Vout2_ok	Vout2 regulated	0	Vout2 is deviating from the target value
			1	Vout2 is regulated to the target value
5	VGG_ok	gate driver regulation is ok	0	gate driver is not available
			1	gate driver is available
4	Tj_err	device temperature is too high	0	device temperature below $T_{sd(otp)}$
			1	device temperature above $T_{sd(otp)}$
3	VIN_UV	VIN under voltage	0	under voltage not detected at VIN
			1	under voltage detected at VIN
2	VIN_OV	VIN over voltage	0	over voltage not detected at VIN
			1	over voltage detected at VIN
1	SPI_err	SPI error	0	last SPI command was executed correctly
			1	last SPI command was erroneous and has been discarded
0	VGG_err	VGG error	0	VGG overload protection not active
			1	VGG overload protection has turned on and VGG is deactivated

8.10.1 Bit VIN_OV

The bit VIN_OV depends on the battery monitoring functionality as described in [Section 8.8](#). It indicates that the device has detected an overvoltage condition and entered the Fail silent mode. A write access to the diagnostic register, or once the Off mode is entered, clears the bit. The device stays in Fail silent mode irrespective of the clearing of the bit.

8.10.2 Bit VIN_UV

The bit VIN_UV depends on the battery monitoring functionality as described in [Section 8.8](#). It indicates that the device has detected an undervoltage condition and entered the Fail silent mode. A write access to the diagnostic register, or once the Off mode is entered, clears the bit. The device stays in Fail silent mode irrespective of the clearing of the bit.

8.10.3 Bit SPI_err

The device evaluates all SPI accesses to the device for the correctness of the commands. When the command is not allowed, the SPI_err bit is set. A write access to the diagnostic register, or once Off mode has been entered, clears the bit.

8.10.4 Bit Tj_err

The bit Tj_err indicates that the junction temperature has exceeded the maximum allowable temperature, and the device has entered Fail silent mode. A write access to the diagnostic register, or once Off mode has been entered, clears the bit. The device stays in Fail silent mode irrespective of the clearing of the bit. After leaving the OFF mode (at IC start-up), it is possible that bit Tj_err is set. To avoid wrong diagnostics, clear the diagnostic register before it is evaluated.

8.10.5 Bit VGG_err

Bit VGG_err is set when the gate driver does not reach the VGG_ok_window (when V_{VGG} is within range) within the regulator voltage start-up error time. Once bit VGG_err is set, it indicates that an error on the gate driver has been detected and the device has entered Fail silent mode. A write access to the diagnostic register, or once Off mode has been entered, clears the bit. The device stays in Fail silent mode irrespective of the clearing of the bit.

8.10.6 Bit VGG_ok

The bit VGG_ok indicates that the gate driver is regulated to the target voltage and allows the gate drivers to drive the gate driver pins. If the gate driver is outside the VGG_ok window after $t_{startup}$, and V_{VGG} is within range, the device clears VGG_ok bit and enters Fail silent mode.

8.10.7 Bits Vout1_ok and Vout2_ok

The bits Vout1_ok and Vout2_ok indicate whether the output voltage is regulated to the target value or deviating from the target value. The bits are set as soon as the corresponding output is within the Vout_ok window (when V_O is within the range) for more than $t_{ftr(ov)}$. The bits are cleared when the corresponding output is outside the Vout_ok window for more than $t_{ftr(ov)}$.

8.11 Serial Peripheral Interface (SPI)

The ASL4500SHN uses an SPI interface to communicate with an external microcontroller. The SPI interface can be used for setting the LEDs current, reading and writing the control register.

8.11.1 SPI introduction

The Serial Peripheral Interface (SPI) provides the communication link with the microcontroller, supporting multi-slave operations. The SPI is configured for full duplex data transfer, so status information is returned when new control data is shifted in. The interface also offers a read-only access option, allowing the application to read back the registers without changing the register content.

The SPI uses four interface signals for synchronization and data transfer:

- CSB - SPI chip select; active LOW
- SCLK - SPI clock - default level is LOW due to low-power concept
- SDI - SPI data input
- SDO - SPI data output - floating when pin CSB is HIGH

Bit sampling is performed on the falling clock edge and data is shifted on the rising clock edge as illustrated in [Figure 8](#).

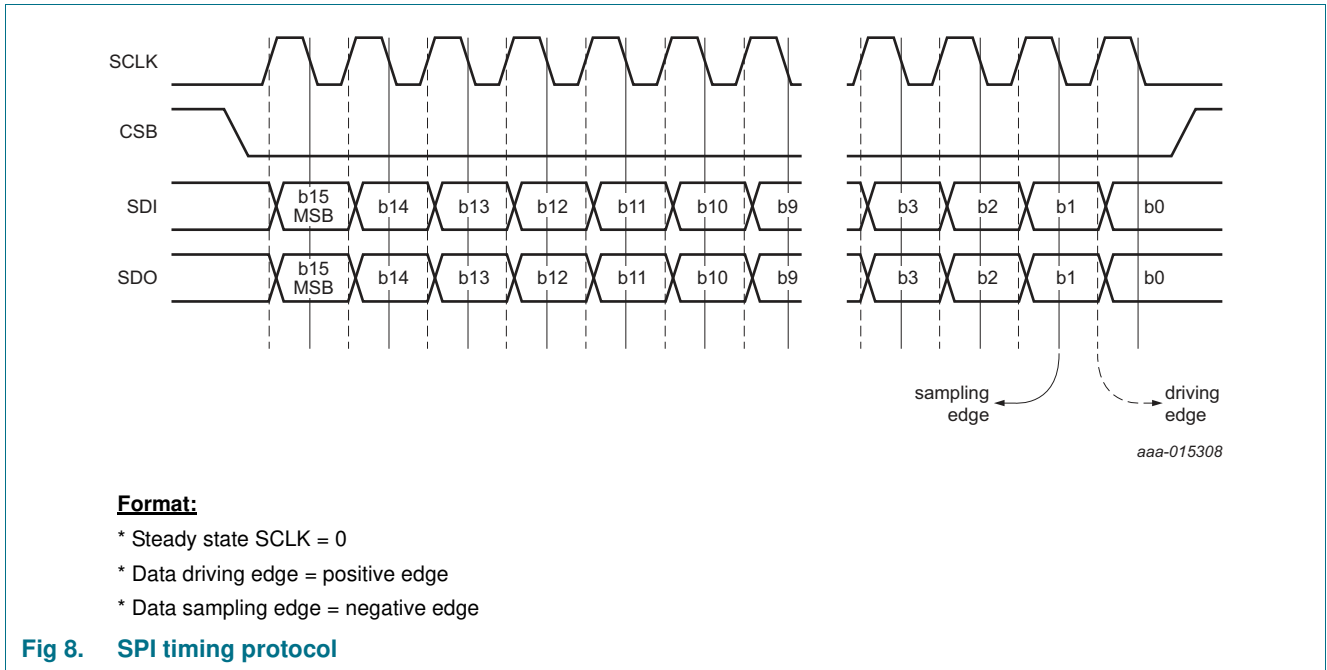

The data bits of the ASL4500SHN are arranged in registers of one-byte length. Each register is assigned to a 7-bit address. For writing into a register, 2 bytes must be sent to the LED driver. The first byte is an identifier byte that consists of the 7-bit address and one read-only bit. For writing, the read-only bit must be set to 0. The second byte is the data that is written into the register, so an SPI access consists of at least 16 bits.

The SPI frame format is shown in [Figure 9](#), [Table 34](#) and [Table 35](#).

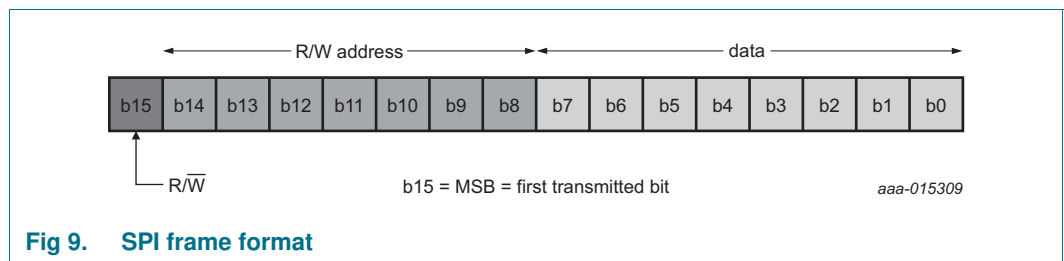

Table 34. SPI frame format for a transition to the device

Bit	Symbol	Description	Value	Function
15	b15	R/W bit	0	write access
			1	read access
14:8	b14:8	address bits	...	address that is selected
7:0	b7:0	data bits	...	data that is transmitted

Table 35. SPI frame format for a transition from the device

Bit	Symbol	Description	Value	Function ^[1]
8:15	b8:15	diagnostic register	...	content of diagnostic register
7:0	b7:0	data bits	...	when previous command was a valid read command, content of the register that is supposed to be read
			...	when previous command was a valid write command, new content of the register that was supposed to be written

[1] The first SPI command after leaving the Off mode, will return 0x00h.

The Master initiates the command sequence. The sequence begins with CSB pin pulled low and lasts until it is asserted high.

The ASL4500SHN also tolerates SPI accesses with a multiple of 16 bits. It allows a daisy chain configuration of the SPI.

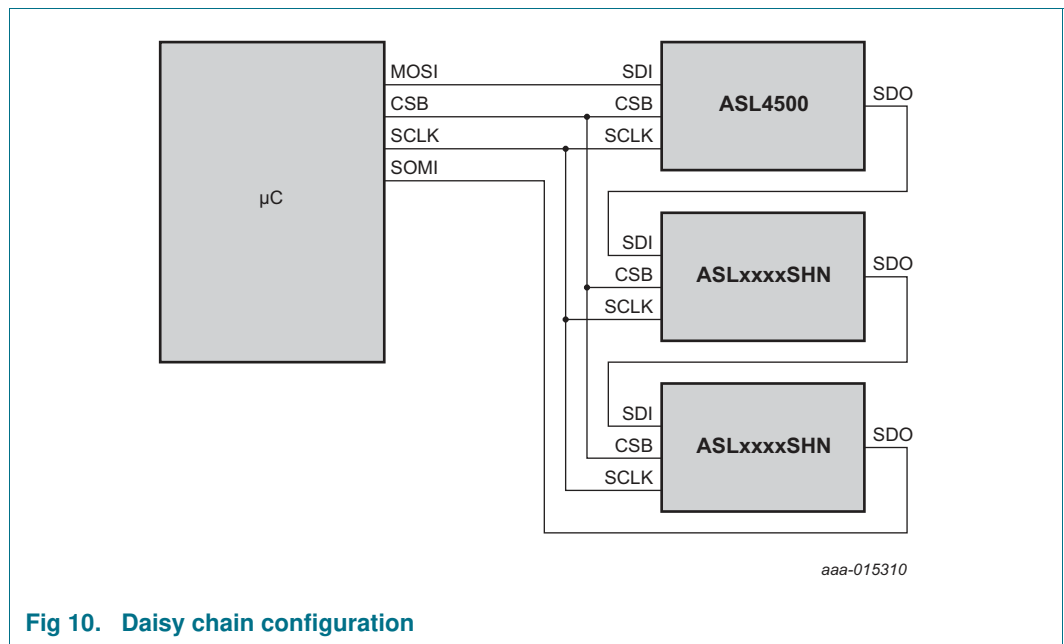

Fig 10. Daisy chain configuration

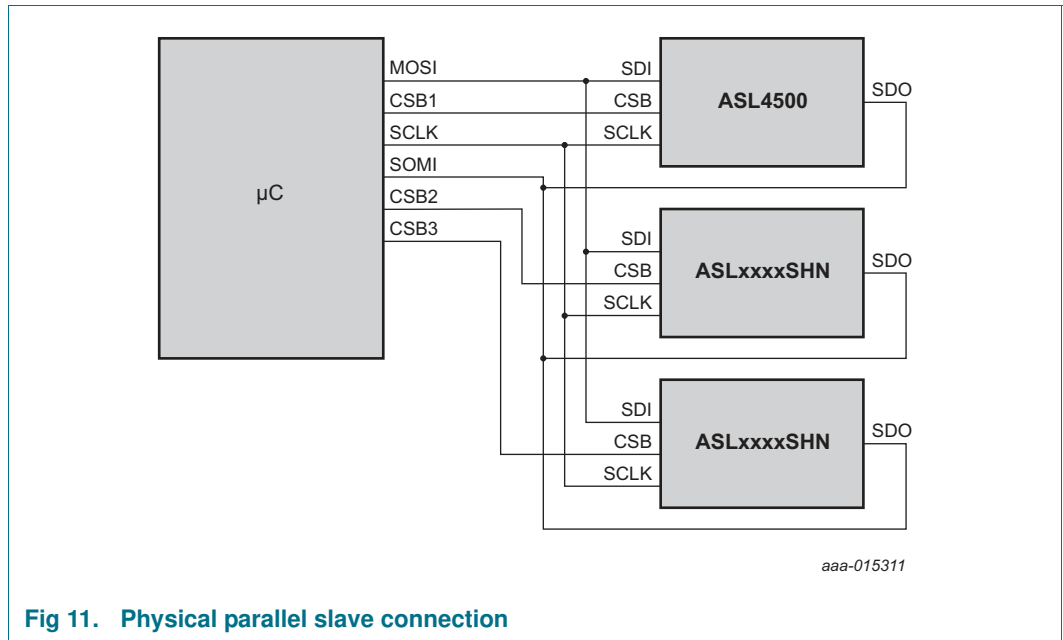

Fig 11. Physical parallel slave connection

During the SPI data transfer, the identifier byte and the actual content of the addressed registers is returned via the SDO pin. The same happens for pure read accesses. Here the read-only bit must be set on logic 1. The content of the data bytes that are transmitted to the ASL4500SHN is ignored.

The ASL4500SHN monitors the number of data bits that are transmitted. If the number is not 16, or a multiple of 16, then a write access is ignored and the SPI error indication bit is set.

8.11.2 Typical use case illustration (Write/Read)

Consider a daisy chain scheme with one master connected to 4 slaves in daisy chain fashion. The following commands are performed during one sequence (first sequence):

- Write data 0xFF to the register 0x1A Slave 1
- Read from register 0x02 of Slave 2
- Write data 0xAF to the register 0x2F of Slave 3
- Read from register 0x44 of Slave 4

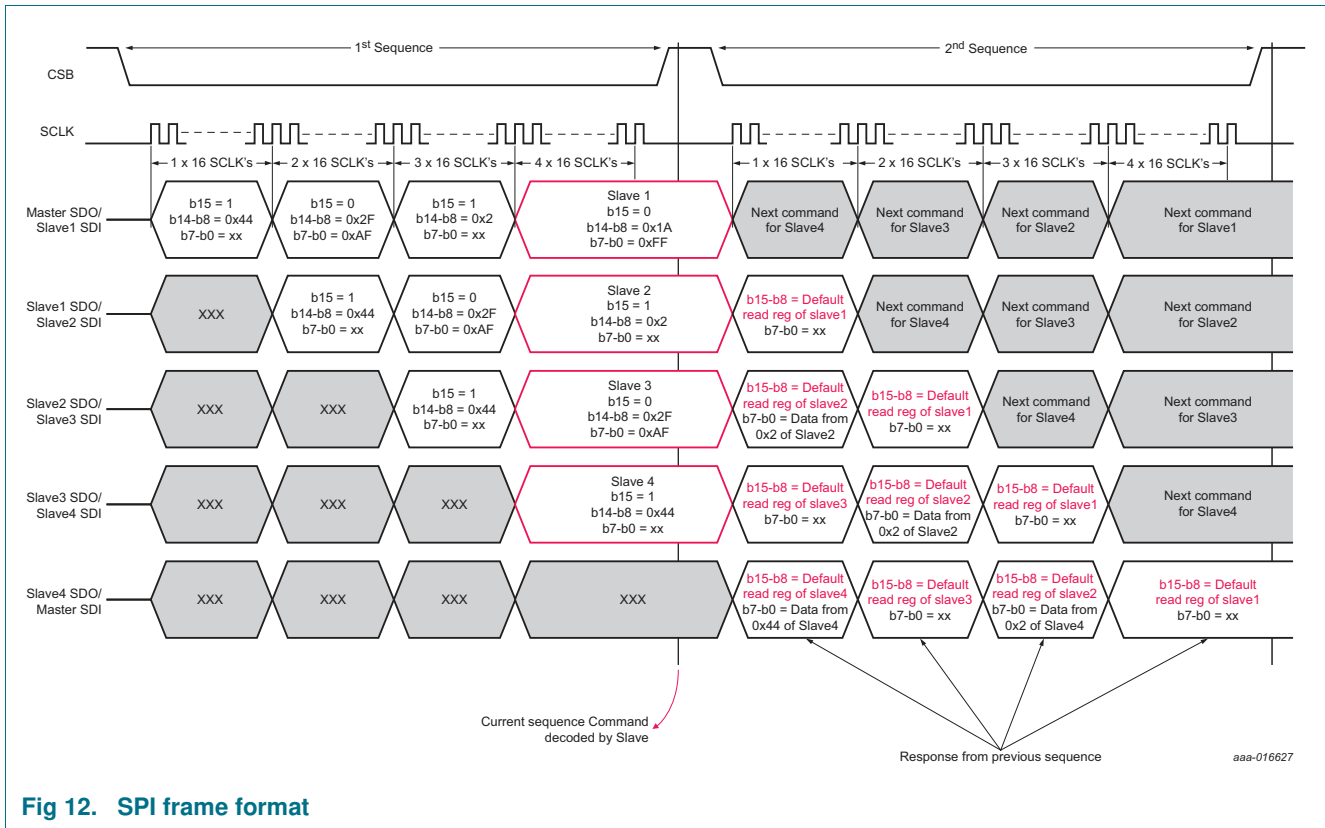

Fig 12. SPI frame format

8.11.3 Diagnostics for the SPI interface

The device is evaluating all SPI access to the device for the correctness of the commands. When the command is not allowed, the SPI_err bit is set.

The conditions that are considered as erratic accesses are:

- SPI write is attempted to a read-only location or reserved location
- SPI write is attempted during operation to a configuration register
- SPI read is attempted from a reserved location
- SPI command does not consist of a multiple of 16 clock counts

If an SPI access is considered to be erratic, no modifications to a SPI register are made. The access after the erratic SPI command returns the diagnostic register and zero in the data field.

For details concerning the SPI_err bit, see chapter [Section 8.10](#).

8.11.4 Register map

The addressable register space amounts to 128 registers from 0x00 to 0x7F. They are separated into 2 groups as shown in [Table 36](#). The register mapping is shown in [Table 37](#) and [Table 40](#). The functional description of each bit can be found in the dedicated chapter.

Table 36. Grouping of the register space

Address range	Description	Content
0x00...0x1F	control registers	control registers
0x20...0x7F	diagnostic registers	diagnostic information

8.11.4.1 Control registers

Table 37. Control register group overview

Address	Name	Reset value	7	6	5	4	3	2	1	0
0x00h	function control	0x00h	-	-	-	-	Cnt_CSB	Vout2en ^[1]	Vout1en ^[1]	Cfg_dn
0x01h	gate driver enable	0x00h	-	-	-	-	EN_G4 ^[2]	EN_G3 ^[2]	EN_G2 ^[2]	EN_G1 ^[2]
0x03h	target voltage output 1	0x00h	V_Vout_1[7:0]							
0x04h	target voltage output 2	0x00h	V_Vout_2[7:0]							
0x05h	limit voltage output 1	0x00h	Vmax_Vout_1[7:0]							
0x06h	limit voltage output 2	0x00h	Vmax_Vout_2[7:0]							
0x07h	maximum phase current Vout1	0x46h	I_max_per_phase_Vout_1[7:0]							
0x08h	maximum phase current Vout2	0x46h	I_max_per_phase_Vout_2[7:0]							
0x1Ch	frequency trimming register	0x09h	-	-	Freq_trim[5:0]					

[1] Bits are locked with bit Cfg_dn is high. When bit Cfg_dn is low, bits can be changed. Read is always possible.

[2] Individual gate drivers that are enabled when Cfg_dn and VGG_ok are set high, can be turned on and off during operation of the system. Gate drivers, disabled when bits Cfg_dn and VGG_ok are set high, remain off, even when the gate enable bits are set high later.

8.11.4.2 Configuration registers

The configuration registers inside the control block can only be written in configuration mode. In the other modes, this register can only be read.

Table 38. Configuration register group overview

Address	Name	Reset value	7	6	5	4	3	2	1	0
0x02h	gate driver output	0x00h	-	-	-	-	O_G4	O_G3	O_G2	O_G1
0x09h	clock divider for output 1	0x0Fh	Clkdiv1[7:0]							
0x0Ah	clock divider for output 2	0x0Fh	Clkdiv2[7:0]							
0x0Bh	internal phases output 1	0x0Fh	-	-	-	-	EN_P4_1	EN_P3_1	EN_P2_1	EN_P1_1
0x0Ch	internal phases output 2	0x0Fh	-	-	-	-	EN_P4_2	EN_P3_2	EN_P2_2	EN_P1_2
0x0Dh	phase off and delay output 1	0x39h	Phdel1				Phoff1			
0x0Eh	phase off and delay output 2	0x39h	Phdel2				Phoff2			
0x0Fh	gate driver phase	0x00h	-	-	-	-	O_GP4	O_GP3	O_GP2	O_GP1
0x10h	phase selection configuration	0xE4h	Phsel4		Phsel3		Phsel2		Phsel1	
0x11h	loop filter proportional configuration	0x00h	Prop2[3:0]				Prop1[3:0]			
0x12h	loop filter integral configuration	0x00h	Integ2[3:0]				Integ1[3:0]			
0x13h	slope compensation configuration	0x88h	Slpcmp2[3:0]				Slpcmp1[3:0]			
0x14h	current sense slope resistor configuration	0x00h	Slpr4[1:0]		Slpr3[1:0]		Slpr2[1:0]		Slpr1[1:0]	
0x15h	gate driver control	0xFFh	VGG[7:0]							
0x1Ah	overvoltage detection threshold	0xFFh	V_VIN_OV[7:0]							
0x1Bh	undervoltage detection threshold	0x00h	V_VIN_UV[7:0]							

8.11.4.3 Internal registers

The ASL4500SHN uses the SPI registers to control some internal functions. In order to avoid any unintended behavior of the device, do not modify these registers but leave them all at their default value.

Table 39. Internal register group

Address	Name	Reset value	7	6	5	4	3	2	1	0
0x19h	internal 1	0x82h	-	-	-	-	-	-	-	-
0x25h	internal 2	0x27h	-	-	-	-	-	-	-	-
0x26h	internal 3	0x3Bh	-	-	-	-	-	-	-	-
0x2Fh	internal 4	0xE8h	-	-	-	-	-	-	-	-
0x30h	internal 5	0x09h	-	-	-	-	-	-	-	-

8.11.4.4 Diagnostic registers

The ASL4500SHN provides diagnostic data via some SPI registers. These registers are read only, but error bits can be cleared via a write access to the register.

Table 40. Diagnostic register group overview

Address	Name	7	6	5	4	3	2	1	0	
0x41h	CSB count low	CSB_cnt[7:0]								
0x42h	CSB count high	CSB_cnt[15:8]								
0x45h	battery voltage	V_VBAT[7:0]								
0x46h	junction temperature	T_junction[7:0]								
0x5Fh	diagnostic register	Vout1_ok	Vout2_ok	VGG_ok	Tj_err	VIN_UV	VIN_OV	SPI_err	VGG_err	

9. Limiting values

Table 41. Limiting values

In accordance with the Absolute Maximum Rating System (IEC 60134).

Symbol	Parameter	Conditions	Min	Max	Unit
V _{BAT}	battery supply voltage	EN = low	-0.3	+60	V
		EN = high	-0.3	+40	V
V _{VCC}	voltage on pin VCC		-0.3	+5.5	V
V _{GND}	ground supply voltage	voltage between ground pins	-0.6	+0.6	V
V _{FBx}	voltage on feedback pins	FB1 and FB2	-0.3	+90	V
V _O	output voltage	programmed target voltage according to registers 0x03h and 0x04h	10	80	V
V _{I(dig)}	digital input voltage	voltage on digital pins SDO, SDI, CSB, SCLK and EN	-0.3	+5.5	V
V _{VGG}	voltage on pin VGG ^[1]	VGG1 ^[2]	-0.3	+10	V
		VGG2 ^[2]	-0.3	+10	V
V _{sense}	sense voltage	voltage on sense pins SNH1, SNH2, SNH3, SNH4, SNL1, SNL2, SNL3 and SNL4	-0.3	+1.8	V
V _{Gx}	voltage on gate pins	voltage on gate pins G1, G2, G3 and G4	-0.3	+10	V
T _j	junction temperature		-40	+175	°C
T _{stg}	storage temperature		-55	+175	°C
V _{ESD}	electrostatic discharge voltage	HBM ^[3]			
		at any pin	-2	+2	kV
		at pin VBAT with 100 nF at pin	-6	+6	kV
		CDM ^[4]			
		at any pin	-500	+500	V

[1] VGG refers to both VGG1 and VGG2.

[2] VGG1 and VGG2 are IC internally connected (shorted).

[3] Human Body Model (HBM): according to AEC-Q100-002 (100 pF, 1.5 kΩ)

[4] Charged Device Model (CDM): according to AEC-Q100-011 (field Induced charge; 4 pF).

10. Thermal characteristics

Table 42. Thermal characteristics

Symbol	Parameter	Conditions	Typ	Unit
R _{th(tot)}	total thermal resistance	HVQFN32 package JEDEC ^[1]	37	K/W

[1] In accordance with JEDEC, JESD51-2, JESD51-5 and JESD51-7 with natural convection on 2s2p board. Board with two inner copper layers (thickness: 35 μm) and thermal via array, under the exposed pad connected to the first inner copper layer.

11. Static characteristics

Table 43. Static characteristics

Min and Max values are specified for the following conditions: $V_{BAT} = 5.5\text{ V to }40\text{ V}$, $V_{EN} = 4.5\text{ V to }5.5\text{ V}$, $V_{VCC} = 4.5\text{ V to }5.5\text{ V}$ and $T_j = -40\text{ °C to }+175\text{ °C}$ [1]. All voltages are defined with respect to ground, positive currents flow into the IC. Typical values are given at $V_{VIN} = 40\text{ V}$, $V_{EN} = 5\text{ V}$, $V_{VCC} = 5\text{ V}$ and $T_j = 25\text{ °C}$ unless otherwise specified.

Symbol	Parameter	Conditions	Min	Typ	Max	Unit
Supply pin Vbat						
I_{DD}	supply current	Operating; no load on VGG; Gate pins low; one phase; one output	5	13	-	mA
		Operating; no load on VGG; Gate pins low; four phases, two outputs	-	20	-	mA
I_{off}	off-state current	EN = low	-	-	5	μA
$V_{th(det)pon}$	power-on detection threshold voltage		-	-	4.5	V
Supply pin VCC						
I_{VCC}	supply current on pin VCC	EN = high; CSB = low	-	-	250	μA
Pin EN						
I_{EN}	current on pin EN	EN = high	-	-	2	mA
Output voltage						
$V_{O(acc)}$	output voltage accuracy	Vout1: operating accuracy 1	$-0.03 \times V_{out1} - 0.711$	-	$+0.03 \times V_{out1} + 0.711$	V
		Vout2: operating accuracy 2	$-0.03 \times V_{out2} - 0.711$	-	$+0.03 \times V_{out2} + 0.711$	V
V_O	output voltage	bit Vout1_ok/Vout2_ok is set when V_O is within the range regarding the target value	-5.4	-	+2.4	V
Regulated voltage output						
V_{VGG}	voltage on pin VGG[2]	$V_{BAT} \geq V_{VGG} + V_{do(reg)VGG}$	4.46	-	10.04	V
		bit VGG_ok is set when V_{VGG} is within the range regarding the target value	-2.4	-	+2.4	V
$V_{do(reg)VGG}$	regulator dropout voltage on pin VGG	$I_{VGG} \leq 50\text{ mA}$; regulator in saturation	-	0.5	1.0	V
		$I_{VGG} \leq 160\text{ mA}$; regulator in saturation	-	1.6	3.2	V
$V_{reg(acc)VGG}$	regulator voltage accuracy on pin VGG	25 °C to $T_{j(max)}$	-5	-	+5	%
		-40 °C to +25 °C	-7	-	+5	%
Serial peripheral interface inputs; pins SDI, SCLK and CSB						
$V_{th(sw)}$	switching threshold voltage		$0.3V_{CC}$	-	$0.7V_{CC}$	V
$R_{pd(int)SCLK}$	internal pull-down resistance on pin SCLK		40	-	80	k Ω
$R_{pd(int)CSB}$	internal pull-down resistance on pin CSB		40	-	80	k Ω
$R_{pd(int)SDI}$	internal pull-down resistance on pin SDI		40	-	80	k Ω

Table 43. Static characteristics ...continued

Min and Max values are specified for the following conditions: $V_{BAT} = 5.5\text{ V to }40\text{ V}$, $V_{EN} = 4.5\text{ V to }5.5\text{ V}$, $V_{VCC} = 4.5\text{ V to }5.5\text{ V}$ and $T_j = -40\text{ }^\circ\text{C to }+175\text{ }^\circ\text{C}$ [1]. All voltages are defined with respect to ground, positive currents flow into the IC. Typical values are given at $V_{VIN} = 40\text{ V}$, $V_{EN} = 5\text{ V}$, $V_{VCC} = 5\text{ V}$ and $T_j = 25\text{ }^\circ\text{C}$ unless otherwise specified.

Symbol	Parameter	Conditions	Min	Typ	Max	Unit
Serial peripheral interface data output; pin SDO						
V_{OH}	HIGH-level output voltage	$I_{OH} = -4\text{ mA}$; $V_{CC} = 4.5\text{ V to }5.5\text{ V}$	$V_{CC} - 0.4$	-	-	V
V_{OL}	LOW-level output voltage	$I_{OL} = -4\text{ mA}$; $V_{CC} = 4.5\text{ V to }5.5\text{ V}$	-	-	0.4	V
I_{LOZ}	OFF-state output leakage current	$V_{CSB} = V_{CC}$; $V_O = 0\text{ V to }V_{CC}$; $V_{CC} = 4.5\text{ V to }5.5\text{ V}$	-5	-	+5	μA
Temperature protection						
ΔT_j	junction temperature variation	measurement provided via register 0x46h; $T_j = 130\text{ }^\circ\text{C}$	-20	-	+20	$^\circ\text{C}$
$T_{sd(otp)}$	overtemperature protection shutdown temperature		150	175	200	$^\circ\text{C}$
V_{BAT} monitoring						
ΔV_{BAT}	battery voltage accuracy	accuracy of V_{BAT} measurement	$-0.035 \times V_{BAT}$ $- 0.3555$	-	$+0.035 \times V_{BAT}$ $+ 0.3555$	%

- [1] All parameters are guaranteed over the virtual junction temperature range by design. Factory testing uses correlated test conditions to cover the specified temperature and power supply voltage range.
- [2] VGG refers to both VGG1 and VGG2.

12. Dynamic characteristics

Table 44. Dynamic characteristics

Min and Max values are specified for the following conditions: $V_{BAT} = 5.5\text{ V to }40\text{ V}$, $V_{EN} = 4.5\text{ V to }5.5\text{ V}$, $f_{osc} = 130\text{ MHz to }200\text{ MHz}$, $V_{CC} = 4.5\text{ V to }5.5\text{ V}$, and $T_j = -40\text{ }^\circ\text{C to }+175\text{ }^\circ\text{C}$ [1]. All voltages are defined with respect to ground. Positive currents flow into the IC. Typical values are given at $V_{BAT} = 12\text{ V}$, $V_{EN} = 5\text{ V}$, $V_{CC} = 5\text{ V}$ and $T_j = 25\text{ }^\circ\text{C}$ unless otherwise specified.

Symbol	Parameter	Conditions	Min	Typ	Max	Unit
f_{DCDC}	DC-to-DC converter frequency		125	-	700	kHz
$f_{(DCDC)acc}$	DC-to-DC converter frequency accuracy	operating, trimmed	-5	-	+5	%
f_{osc}	oscillator frequency	internal oscillator, untrimmed	130	-	250	MHz
		target frequency for trimmed operation	-	180	-	MHz
$t_{startup}$	start-up time	EN high until SPI is operational	-	-	150	μs
Serial peripheral interface timing; pins CSB, SCLK, SDI and SDO						
$f_{clk(int)}/f_{SPI}$	Internal clock frequency to SPI clock frequency ratio		-	20:1	-	1
$t_{cy}(clk)$	clock cycle time		250	-	-	ns
$t_{SPILEAD}$	SPI enable lead time		50	-	-	ns
t_{SPILAG}	SPI enable lag time		50	-	-	ns
$t_{clk(H)}$	clock HIGH time		125	-	-	ns
$t_{clk(L)}$	clock LOW time		125	-	-	ns
$t_{su(D)}$	data input set-up time		50	-	-	ns
$t_{h(D)}$	data input hold time		50	-	-	ns
$t_{v(Q)}$	data output valid time	pin SDO; $C_L = 20\text{ pF}$	-	-	130	ns

Table 44. Dynamic characteristics ...continued

Min and Max values are specified for the following conditions: $V_{BAT} = 5.5\text{ V to }40\text{ V}$, $V_{EN} = 4.5\text{ V to }5.5\text{ V}$, $f_{osc} = 130\text{ MHz to }200\text{ MHz}$, $V_{CC} = 4.5\text{ V to }5.5\text{ V}$, and $T_j = -40\text{ }^\circ\text{C to }+175\text{ }^\circ\text{C}$ [1]. All voltages are defined with respect to ground. Positive currents flow into the IC. Typical values are given at $V_{BAT} = 12\text{ V}$, $V_{EN} = 5\text{ V}$, $V_{CC} = 5\text{ V}$ and $T_j = 25\text{ }^\circ\text{C}$ unless otherwise specified.

Symbol	Parameter	Conditions	Min	Typ	Max	Unit
$t_{WH(S)}$	chip select pulse width HIGH		250	-	-	ns
Gate driver						
$t_{ch(g)}$	gate charge time	20 % to 80 %; $V_{GG} = 7.5\text{ V}$; $C_{gate} = 2000\text{ pF}$	-	-	30	ns
$t_{dch(g)}$	gate discharge time	80 % to 20 %; $V_{GG} = 7.5\text{ V}$; $C_{gate} = 2000\text{ pF}$	-	-	14	ns
Regulated voltage						
$t_{err(startup)}$	start-up error time	of VGG; $f_{osc} = 180\text{ MHz}$	-	2.5	-	ms
t_{err}	error detection time	for VGG during operation; $f_{osc} = 180\text{ MHz}$	-	31.5	-	μs
$t_{ftr(ov)}$	output voltage filter time	for bit Vout1_ok and Vout2_ok; $f_{osc} = 180\text{ MHz}$	-	31.5	-	μs

[1] All parameters are guaranteed over the virtual junction temperature range by design. Factory testing uses correlated test conditions to cover the specified temperature and power supply voltage range.

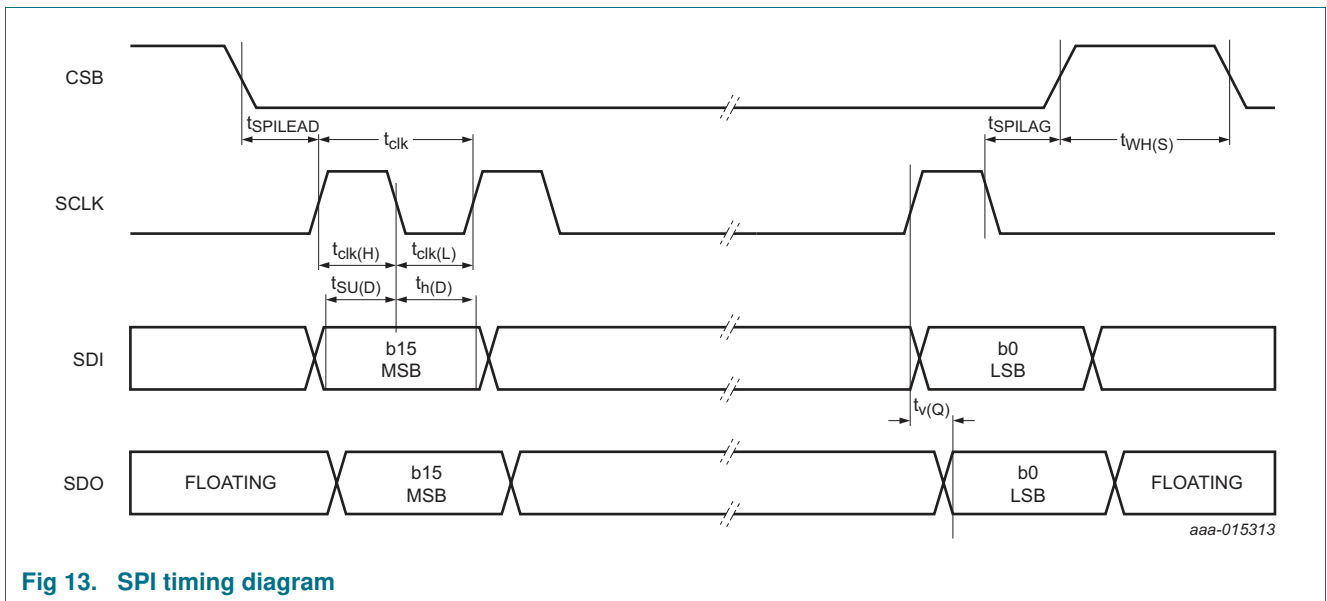
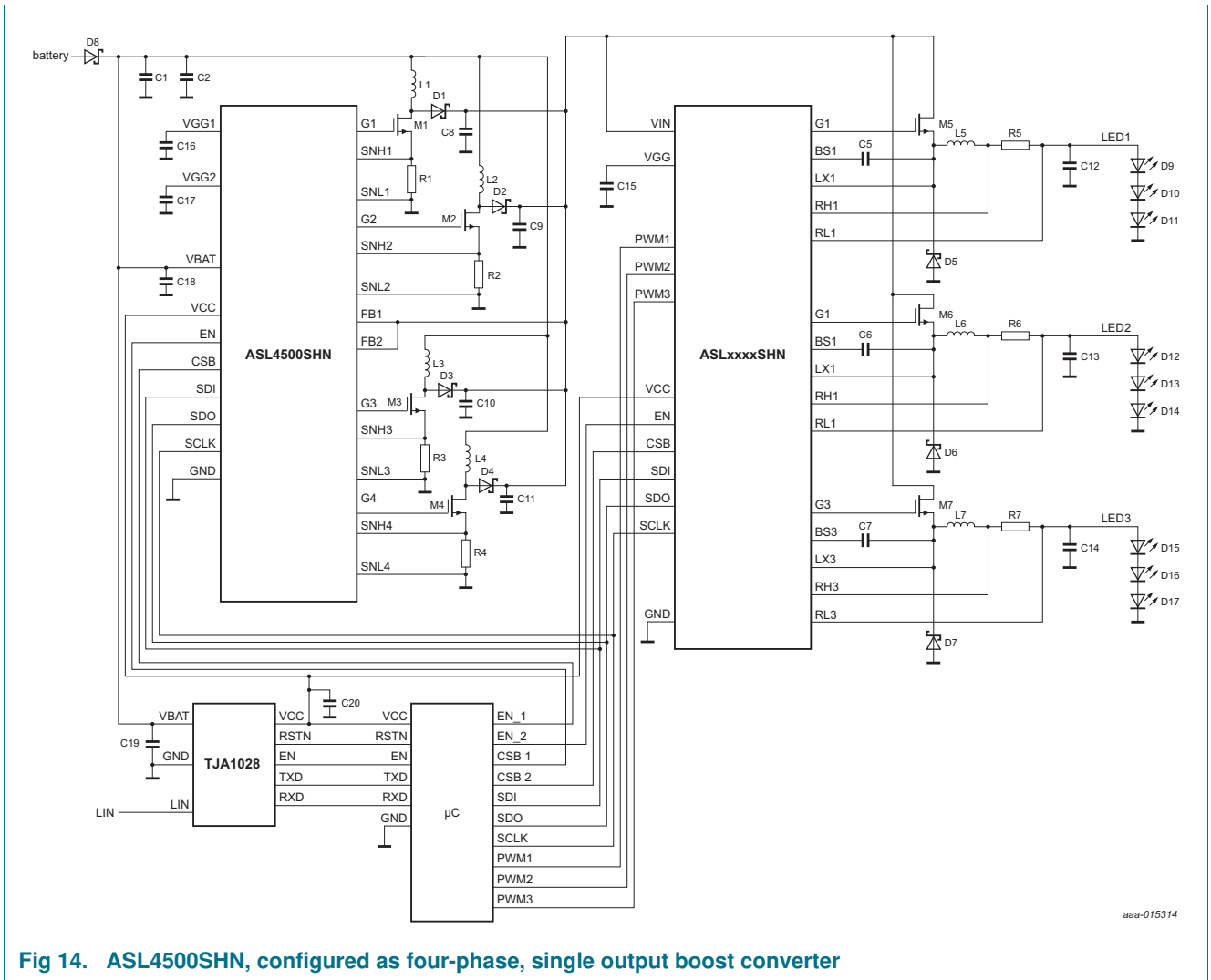

Fig 13. SPI timing diagram

13. Application information

Figure 14 provides an application example for the ASL4500SHN in a typical four-phase boost converter IC with 1 output voltage.



aaa-015314

Fig 14. ASL4500SHN, configured as four-phase, single output boost converter

14. Test information

14.1 Quality information

This product has been qualified in accordance with the Automotive Electronics Council (AEC) standard Q100 Rev-H - *Failure mechanism-based stress test qualification for integrated circuits*, and is suitable for use in automotive applications.

15. Package outline

HVQFN32: plastic thermal enhanced very thin quad flat package; no leads;
32 terminals; body 5 x 5 x 0.85 mm

SOT617-12

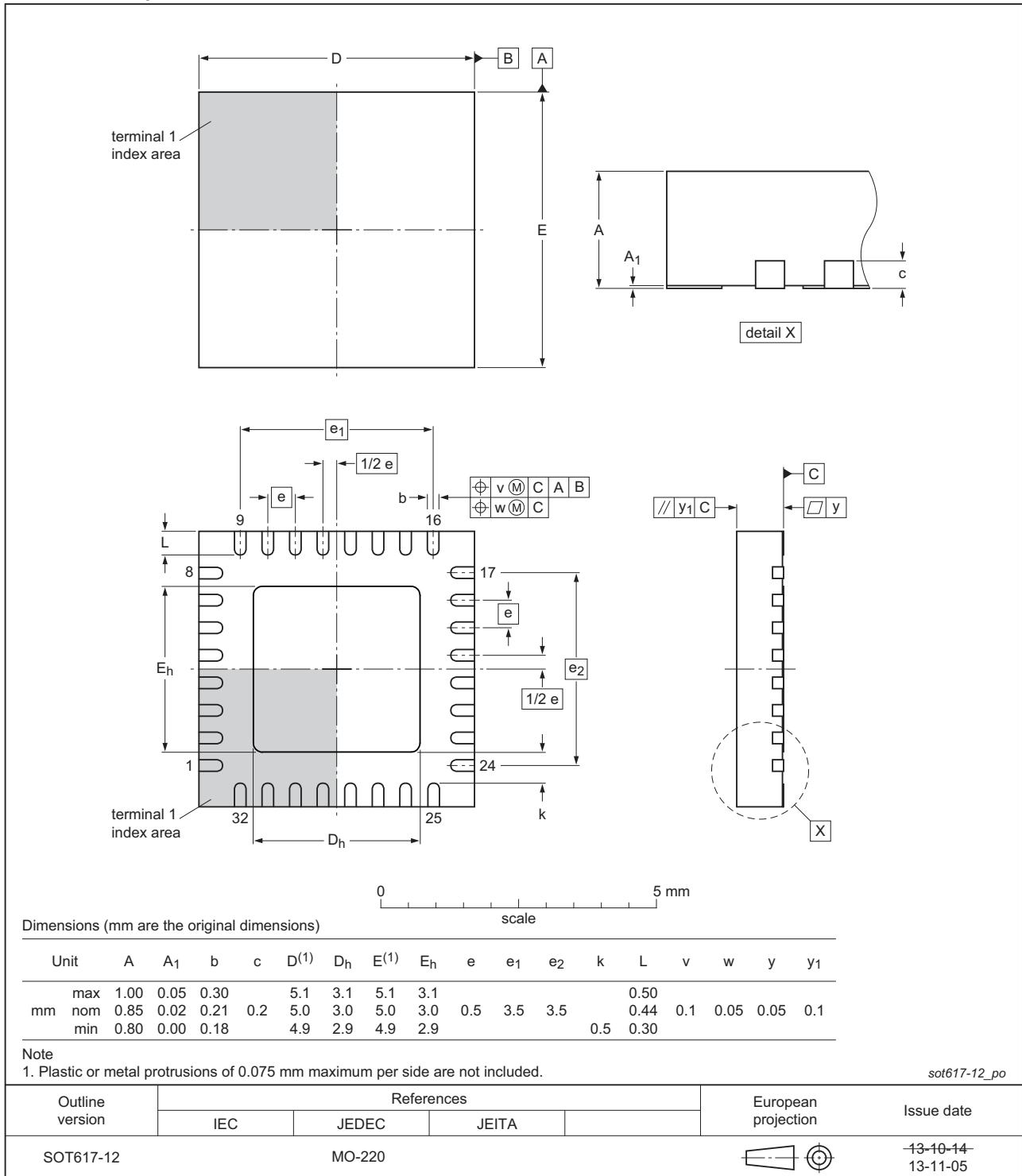

Fig 15. Package outline HVQFN32

16. Revision history

Table 45. Revision history

Document ID	Release date	Data sheet status	Change notice	Supersedes
ASL4500SHN v.6	20171026	Product data sheet	-	ASL4500SHN v.5
Modifications:	<ul style="list-style-type: none"> • Section 8.7: clarified exceeding of limiting values • Formula for voltage conversion updated • Table 43: values of output voltage accuracy updated • Table 43: values of regulator voltage accuracy on pin VGG updated • Table 44: data output valid time updated 			
ASL4500SHN v.5	20160404	Product data sheet	-	ASL4500SHN v.4
Modifications:	<ul style="list-style-type: none"> • Title and address of Table 24 corrected 			
ASL4500SHN v.4	20160321	Product data sheet	-	ASL4500SHN v.3
Modifications:	<ul style="list-style-type: none"> • Minor corrections made to Figure 3. • Text corrections made in accordance with the corrections to Figure 3. • New symbol added to Table 44. 			
ASL4500SHN v.3	20150925	Product data sheet	-	ASL4500SHN v.2
Modifications:	<ul style="list-style-type: none"> • Minor corrections made to Figure 1, Figure 3, Figure 6, Figure 7, Figure 10, Figure 11 and Figure 14. • Phase off and delay output 1 and output 2, bits reassigned in Table 38. • A number of symbols have been upgraded to NXP standards. 			
ASL4500SHN v.2	20150305	Preliminary data sheet	-	ASL4500SHN v.1
ASL4500SHN v.1	20150225	Preliminary data sheet	-	-

17. Legal information

17.1 Data sheet status

Document status ^{[1][2]}	Product status ^[3]	Definition
Objective [short] data sheet	Development	This document contains data from the objective specification for product development.
Preliminary [short] data sheet	Qualification	This document contains data from the preliminary specification.
Product [short] data sheet	Production	This document contains the product specification.

[1] Please consult the most recently issued document before initiating or completing a design.

[2] The term 'short data sheet' is explained in section "Definitions".

[3] The product status of device(s) described in this document may have changed since this document was published and may differ in case of multiple devices. The latest product status information is available on the Internet at URL <http://www.nxp.com>.

17.2 Definitions

Draft — The document is a draft version only. The content is still under internal review and subject to formal approval, which may result in modifications or additions. NXP Semiconductors does not give any representations or warranties as to the accuracy or completeness of information included herein and shall have no liability for the consequences of use of such information.

Short data sheet — A short data sheet is an extract from a full data sheet with the same product type number(s) and title. A short data sheet is intended for quick reference only and should not be relied upon to contain detailed and full information. For detailed and full information see the relevant full data sheet, which is available on request via the local NXP Semiconductors sales office. In case of any inconsistency or conflict with the short data sheet, the full data sheet shall prevail.

Product specification — The information and data provided in a Product data sheet shall define the specification of the product as agreed between NXP Semiconductors and its customer, unless NXP Semiconductors and customer have explicitly agreed otherwise in writing. In no event however, shall an agreement be valid in which the NXP Semiconductors product is deemed to offer functions and qualities beyond those described in the Product data sheet.

17.3 Disclaimers

Limited warranty and liability — Information in this document is believed to be accurate and reliable. However, NXP Semiconductors does not give any representations or warranties, expressed or implied, as to the accuracy or completeness of such information and shall have no liability for the consequences of use of such information. NXP Semiconductors takes no responsibility for the content in this document if provided by an information source outside of NXP Semiconductors.

In no event shall NXP Semiconductors be liable for any indirect, incidental, punitive, special or consequential damages (including - without limitation - lost profits, lost savings, business interruption, costs related to the removal or replacement of any products or rework charges) whether or not such damages are based on tort (including negligence), warranty, breach of contract or any other legal theory.

Notwithstanding any damages that customer might incur for any reason whatsoever, NXP Semiconductors' aggregate and cumulative liability towards customer for the products described herein shall be limited in accordance with the *Terms and conditions of commercial sale* of NXP Semiconductors.

Right to make changes — NXP Semiconductors reserves the right to make changes to information published in this document, including without limitation specifications and product descriptions, at any time and without notice. This document supersedes and replaces all information supplied prior to the publication hereof.

Suitability for use in automotive applications — This NXP Semiconductors product has been qualified for use in automotive applications. Unless otherwise agreed in writing, the product is not designed, authorized or warranted to be suitable for use in life support, life-critical or safety-critical systems or equipment, nor in applications where failure or malfunction of an NXP Semiconductors product can reasonably be expected to result in personal injury, death or severe property or environmental damage. NXP Semiconductors and its suppliers accept no liability for inclusion and/or use of NXP Semiconductors products in such equipment or applications and therefore such inclusion and/or use is at the customer's own risk.

Applications — Applications that are described herein for any of these products are for illustrative purposes only. NXP Semiconductors makes no representation or warranty that such applications will be suitable for the specified use without further testing or modification.

Customers are responsible for the design and operation of their applications and products using NXP Semiconductors products, and NXP Semiconductors accepts no liability for any assistance with applications or customer product design. It is customer's sole responsibility to determine whether the NXP Semiconductors product is suitable and fit for the customer's applications and products planned, as well as for the planned application and use of customer's third party customer(s). Customers should provide appropriate design and operating safeguards to minimize the risks associated with their applications and products.

NXP Semiconductors does not accept any liability related to any default, damage, costs or problem which is based on any weakness or default in the customer's applications or products, or the application or use by customer's third party customer(s). Customer is responsible for doing all necessary testing for the customer's applications and products using NXP Semiconductors products in order to avoid a default of the applications and the products or of the application or use by customer's third party customer(s). NXP does not accept any liability in this respect.

Limiting values — Stress above one or more limiting values (as defined in the Absolute Maximum Ratings System of IEC 60134) will cause permanent damage to the device. Limiting values are stress ratings only and (proper) operation of the device at these or any other conditions above those given in the Recommended operating conditions section (if present) or the Characteristics sections of this document is not warranted. Constant or repeated exposure to limiting values will permanently and irreversibly affect the quality and reliability of the device.

Terms and conditions of commercial sale — NXP Semiconductors products are sold subject to the general terms and conditions of commercial sale, as published at <http://www.nxp.com/profile/terms>, unless otherwise agreed in a valid written individual agreement. In case an individual agreement is concluded only the terms and conditions of the respective agreement shall apply. NXP Semiconductors hereby expressly objects to applying the customer's general terms and conditions with regard to the purchase of NXP Semiconductors products by customer.

No offer to sell or license — Nothing in this document may be interpreted or construed as an offer to sell products that is open for acceptance or the grant, conveyance or implication of any license under any copyrights, patents or other industrial or intellectual property rights.

Export control — This document as well as the item(s) described herein may be subject to export control regulations. Export might require a prior authorization from competent authorities.

Translations — A non-English (translated) version of a document is for reference only. The English version shall prevail in case of any discrepancy between the translated and English versions.

17.4 Trademarks

Notice: All referenced brands, product names, service names and trademarks are the property of their respective owners.

18. Contact information

For more information, please visit: <http://www.nxp.com>

For sales office addresses, please send an email to: salesaddresses@nxp.com

19. Tables

Table 1. Ordering information	2	Table 22. Maximum phase current Vout1 register (address 0x07h)	15
Table 2. Pin description [1]	4	Table 23. Maximum phase current Vout2 register (address 0x08h)	15
Table 3. Operating modes	6	Table 24. Function control register (address 0x00h)	16
Table 4. Internal phase control enable for output 1 (address 0x0Bh)	8	Table 25. CSB count register 1 (address 0x041h)	17
Table 5. Internal phase control enable for output 2 (address 0x0Ch)	9	Table 26. CSB count register 2 (address 0x042h)	17
Table 6. Gate driver output (address 0x02h)	9	Table 27. Frequency trimming register (address 0x1Ch)	18
Table 7. Gate driver phase, address (address 0x0Fh)	9	Table 28. VGG control register (address 0x15h)	19
Table 8. Gate driver phase, address (address 0x0Fh)	10	Table 29. Battery voltage register (address 0x045h)	20
Table 9. Gate driver enable (address 0x01h)	10	Table 30. Undervoltage threshold register (address 0x01Bh)	20
Table 10. Clock divider for Vout1 (address 0x09h)	11	Table 31. Overvoltage threshold register (address 0x01Ah)	20
Table 11. Clock divider for Vout2 (address 0x0Ah)	11	Table 32. Junction temperature register (address 0x046h)	20
Table 12. Phase-off time and phase delay of output 1 (address 0x0Dh)	11	Table 33. Diagnostic register (address 0x05Fh)	21
Table 13. Phase-off time and phase delay of output 2 (address 0x0Eh)	12	Table 34. SPI frame format for a transition to the device	23
Table 14. Loop filter proportional configuration (address 0x11h)	12	Table 35. SPI frame format for a transition from the device.	24
Table 15. Loop filter integral configuration (address 0x12h)	12	Table 36. Grouping of the register space.	27
Table 16. Slope compensation configuration (address 0x13h)	13	Table 37. Control register group overview	27
Table 17. Current sense slope resistor configuration (address 0x14h)	13	Table 38. Configuration register group overview	28
Table 18. Output voltage 1 register (address 0x03h)	14	Table 39. Internal register group	29
Table 19. Output voltage 2 register (address 0x04h)	14	Table 40. Diagnostic register group overview	29
Table 20. Limit voltage output 1 register (address 0x05h)	14	Table 41. Limiting values	30
Table 21. Limit voltage output 2 register (address 0x06h)	14	Table 42. Thermal characteristics	30
		Table 43. Static characteristics	31
		Table 44. Dynamic characteristics	32
		Table 45. Revision history	37

20. Figures

Fig 1. Block diagram	3
Fig 2. Pin configuration	4
Fig 3. State diagram.	6
Fig 4. Boost converter phase circuit	7
Fig 5. Mapping of virtual phases (V1_1 to V2_4) to physical phases (G1 to G4)	8
Fig 6. Phase control generator	11
Fig 7. Frequency trimming flow	17
Fig 8. SPI timing protocol	23
Fig 9. SPI frame format	23
Fig 10. Daisy chain configuration.	24
Fig 11. Physical parallel slave connection	25
Fig 12. SPI frame format	26
Fig 13. SPI timing diagram	33
Fig 14. ASL4500SHN, configured as four-phase, single output boost converter.	34
Fig 15. Package outline HVQFN32	36

21. Contents

1	Introduction	1	8.11.2	Typical use case illustration (Write/Read) . . .	25
2	General description	1	8.11.3	Diagnostics for the SPI interface	26
3	Features and benefits	2	8.11.4	Register map	26
4	Applications	2	8.11.4.1	Control registers	27
5	Ordering information	2	8.11.4.2	Configuration registers	28
6	Block diagram	3	8.11.4.3	Internal registers	29
7	Pinning information	4	8.11.4.4	Diagnostic registers	29
7.1	Pinning	4	9	Limiting values	30
7.2	Pin description	4	10	Thermal characteristics	30
8	Functional description	6	11	Static characteristics	31
8.1	Operating modes	6	12	Dynamic characteristics	32
8.1.1	Off mode	6	13	Application information	33
8.1.2	Configuration mode	6	14	Test information	35
8.1.3	Operation mode	7	14.1	Quality information	35
8.1.4	Fail silent mode	7	15	Package outline	36
8.2	Boost converter configuration	7	16	Revision history	37
8.2.1	Virtual phase configuration	8	17	Legal information	38
8.2.2	Association of physical phases to the output voltages	9	17.1	Data sheet status	38
8.2.3	Association of connected phases to the internal phase generation	9	17.2	Definitions	38
8.2.4	Enabling of connected phases	10	17.3	Disclaimers	38
8.2.5	Boost converter frequencies configuration . . .	10	17.4	Trademarks	39
8.2.6	Control loop parameter settings	12	18	Contact information	39
8.3	Output voltage programmability	13	19	Tables	40
8.3.1	Output voltage target programmability	13	20	Figures	40
8.3.2	Output overvoltage protection programming .	14	21	Contents	41
8.4	Coil peak current limitation	15			
8.5	Enabling output voltage	16			
8.6	Frequency trimming	16			
8.7	Gate supply voltage	19			
8.7.1	Gate voltage supply diagnostics	19			
8.8	Supply voltage monitoring	19			
8.8.1	Battery voltage measurement	19			
8.8.2	Undervoltage detection	20			
8.8.3	Overvoltage detection	20			
8.9	Junction temperature information	20			
8.10	Diagnostic information	21			
8.10.1	Bit VIN_OV	21			
8.10.2	Bit VIN_UV	21			
8.10.3	Bit SPI_err	21			
8.10.4	Bit Tj_err	22			
8.10.5	Bit VGG_err	22			
8.10.6	Bit VGG_ok	22			
8.10.7	Bits Vout1_ok and Vout2_ok	22			
8.11	Serial Peripheral Interface (SPI)	22			
8.11.1	SPI introduction	22			

Please be aware that important notices concerning this document and the product(s) described herein, have been included in section 'Legal information'.

© NXP Semiconductors N.V. 2017. All rights reserved.

For more information, please visit: <http://www.nxp.com>
 For sales office addresses, please send an email to: salesaddresses@nxp.com

Date of release: 26 October 2017
 Document identifier: ASL4500SHN