



EVALUATION BOARD FOR Si5010 OC-12/3, STM-4/1 SONET/SDH CLOCK AND DATA RECOVERY IC

Description

The Si5010 evaluation board provides a platform for testing and characterizing Silicon Laboratories' Si5010 multi-rate OC-12/3 and STM-4/1 clock and data recovery (CDR) device.

All high-speed I/Os are ac coupled to ease interfacing to industry standard test equipment

Features

- Single 2.5 V power supply
- Differential I/Os ac coupled
- Simple jumper configuration

Function Block Diagram

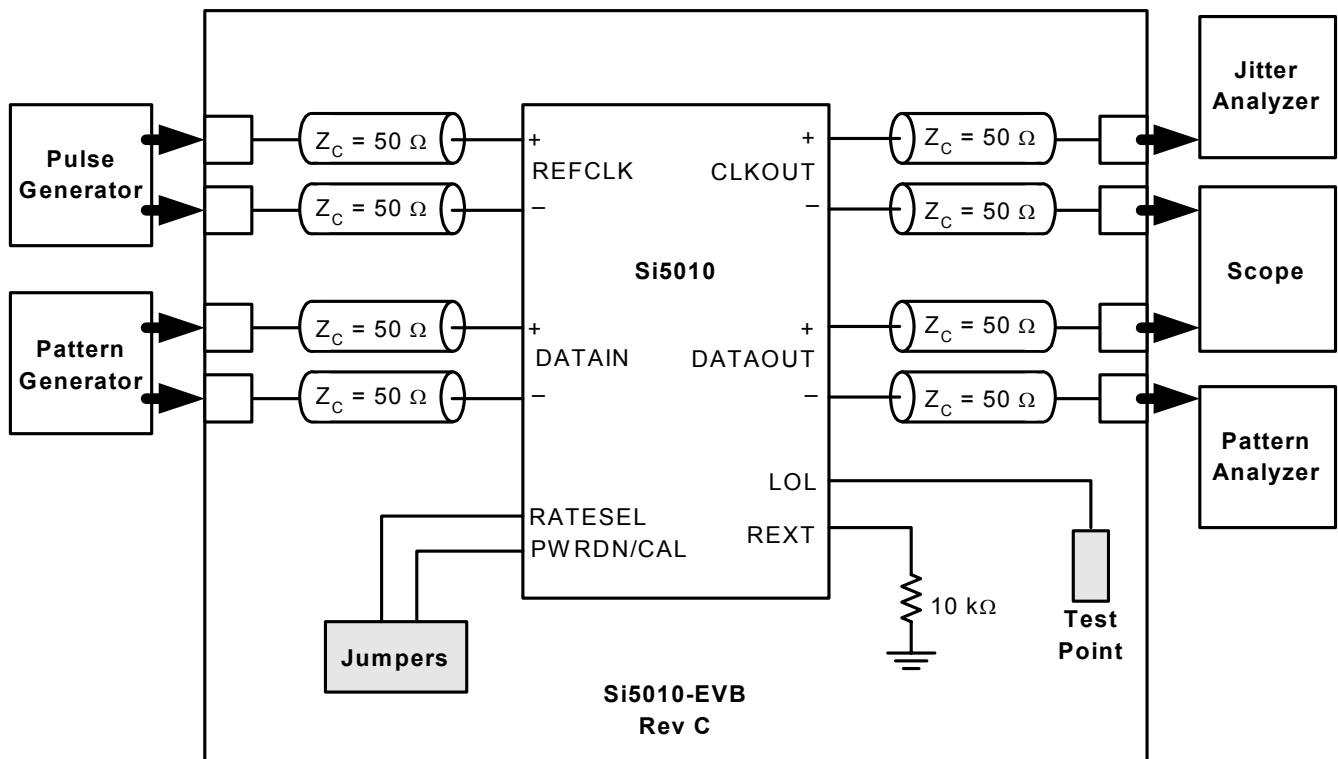

Si5010-EVB

Functional Description

The evaluation board simplifies characterization of the Si5010 clock and data recovery (CDR) device by providing access to all of the Si5010 I/Os. Device performance can be evaluated by following the Test Configuration section below. Specific performance metrics include jitter tolerance, jitter generation, and jitter transfer.

Power Supply

The evaluation board requires one 2.5 V supply. Supply filtering is placed on the board to filter typical system noise components, however, initial performance testing should use a linear supply capable of supplying 2.5 V $\pm 5\%$ dc.

CAUTION: The evaluation board is designed so that the body of the SMA jacks and GND are shorted. Care must be taken when powering the PCB at potentials other than GND at 0.0 V and VDD at 2.5 V relative to chassis GND.

Self-Calibration

The Si5010 device provides an internal self-calibration function that optimizes the loop gain parameters within the internal DSPLL™. Self-calibration is initiated by a high-to-low transition of the PWRDN/CAL signal while a valid reference clock is supplied to the REFCLK input. On the Si5010-EVB board, a voltage detector IC is utilized to initiate self-calibration. The voltage detector drives the PWRDN/CAL signal low after the supply voltage has reached a specific voltage level. This circuit is described in Silicon Laboratories application note AN42. On the Si5010-EVB, the PWRDN/CAL signal is also accessible via a jumper located in the lower left-hand corner of the evaluation board. PWRDN/CAL is wired to the signal post adjacent to the 2.5 V post.

Device Powerdown

The CDR can be powered down via the PWRDN/CAL signal. When asserted the evaluation board will draw minimal current. PWRDN/CAL is controlled via one jumper located in the lower left-hand corner of the evaluation board. PWRDN/CAL is wired to the signal post adjacent to the 2.5 V post.

CLKOUT, DATAOUT, DATAIN

These high-speed I/Os are wired to the board perimeter on 30 mil (0.030 inch) 50 Ω microstrip lines to the end-launch SMA jacks as labeled on the PCB. These I/Os are ac coupled to simplify direct connection to a wide array of standard test hardware. Because each of these signals are differential both the positive (+) and negative (-) terminals must be terminated to 50 Ω . Terminating only one side will adversely degrade the performance of the CDR. The inputs are terminated on the die with 50 Ω resistors.

To improve the DATAOUT eye-diagram, short 100 Ω transmission line segments precede the 50 Ω high-speed traces. These segments increase the interface bandwidth from the chip to the 50 Ω traces and reduce data inter-symbol-interference. Please refer to Silicon Laboratories application note AN43 for more details.

Note: The 50 Ω termination is for each terminal/side of a differential signal, thus the differential termination is actually 50 Ω + 50 Ω = 100 Ω .

REFCLK

REFCLK is used to center the frequency of the DSPLL™ so that the device can lock to the data. Ideally the REFCLK frequency should be 19.44 77.76, or 155.52 MHz, and must have a frequency accuracy of ± 100 PPM. Internally, the CDR automatically recognizes the REFCLK frequency within one of these three frequency ranges. REFCLK is ac coupled to the SMA jacks located on the top side of the evaluation board.

RATESEL

RATESEL is used to configure the CDR to recover clock and data at different data rates. RATESEL is a binary input that is controlled via a jumper located in the lower left-hand corner of the evaluation board. RATESEL is wired to the center post (signal post) between 2.5 V and GND. For example, the OC-12 data rate is selected by jumping RATESEL to 0.0 V.

The table given on the evaluation board lists approximate data rates for the jumper configurations shown in Figure 1.

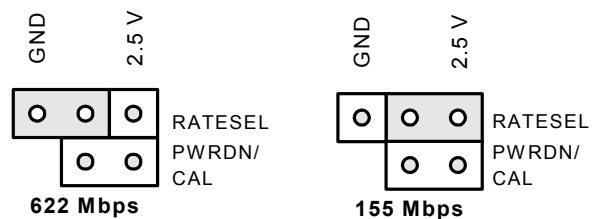

Figure 1. RATESEL Jumper Configurations

Loss-of-Lock (LOL)

LOL is an indicator of the relative frequency between the data and the REFCLK. LOL will assert when the frequency difference is greater than ± 600 PPM. In order to prevent LOL from de-asserting prematurely, there is hysteresis in returning from the out-of-lock condition. LOL will be de-asserted when the frequency difference is less than ± 300 PPM.

LOL is wired to a test point which is located on the upper right-hand side of the evaluation board.

Test Configuration

The three critical tests that are typically performed on a CDR device are jitter transfer, jitter tolerance, and jitter generation. By connecting the Si5010 Evaluation Board as shown in Figure 2, all three measurements can be easily made.

REFCLK should be within ± 100 PPM of 19.44, 77.76, or 155.52 MHz. RATESEL must be configured to match the desired data rate, and PWRDN/CAL must be unjumpered.

Jitter Tolerance: Referring to Figure 2, this test requires a pattern generator, a clock source (synthesizer signal source), a modulation source, a jitter analyzer, a pattern analyzer, and a pulse generator (all unconnected high-speed outputs must be terminated to 50Ω). During this test the Jitter Analyzer causes a modulation on the data pattern which drives the DATAIN ports of the CDR. The Bit-Error-Rate (BER) is monitored on the Pattern Analyzer. The modulation (jitter) frequency and amplitude is recorded when the BER approaches a specified threshold.

Jitter Generation: Referring to Figure 2, this test requires a pattern generator, a clock source (synthesizer signal source), a jitter analyzer, and a pulse generator (all unconnected high-speed outputs must be terminated to 50Ω). During this test, there is no modulation of the Data Clock, so the data that is sent to the CDR is jitter free. The Jitter Analyzer measures the RMS and peak-to-peak jitter on the CDR CLKOUT. Thus, any jitter measured is jitter generated by the CDR.

Jitter Transfer: Referring to Figure 2, this test requires a pattern generator, a clock source (synthesizer signal source), a modulation source, a jitter analyzer, and a pulse generator (all unconnected high-speed outputs must be terminated to 50Ω). During this test the Jitter Analyzer modulates the data pattern and data clock reference. The modulated data clock reference is compared with the CLKOUT of the CDR. Jitter on CLKOUT relative to the jitter on the data clock reference is plotted versus modulation frequency at predefined jitter amplitudes.



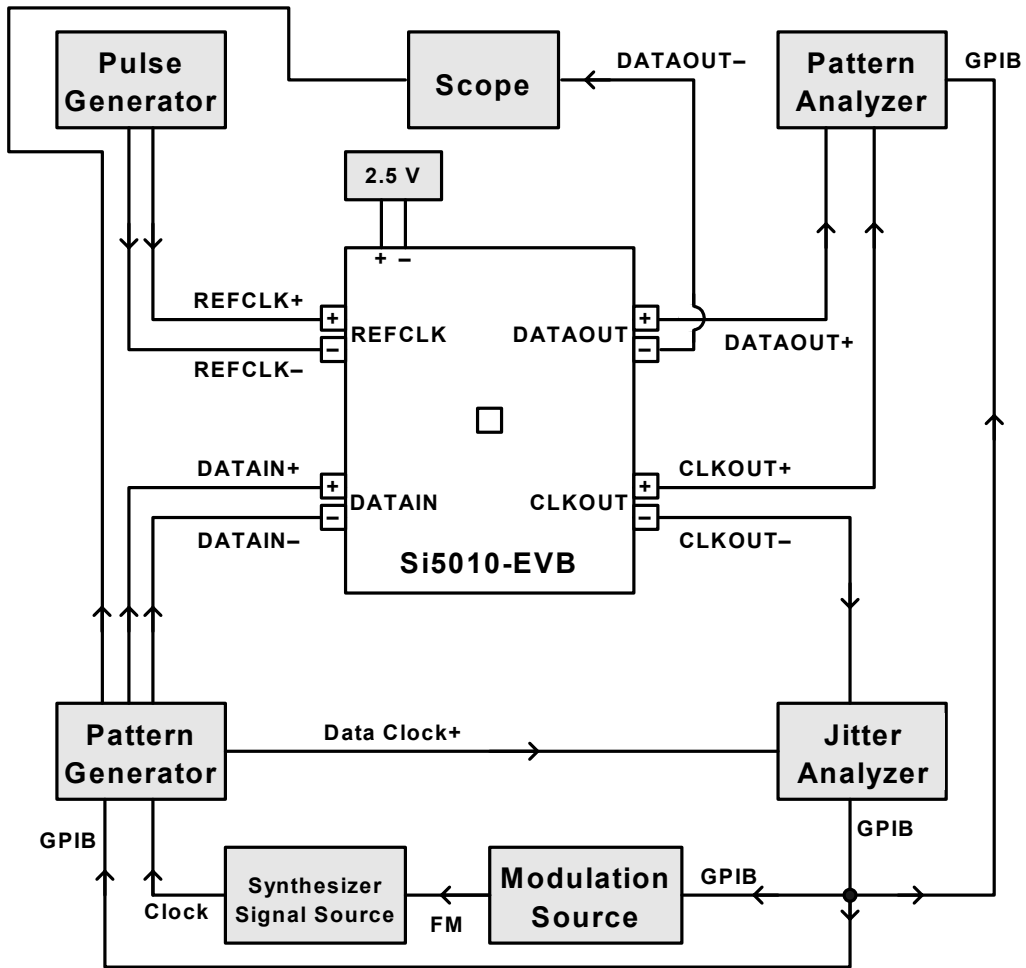

Figure 2. Test Configuration for Jitter Tolerance, Transfer, and Generation

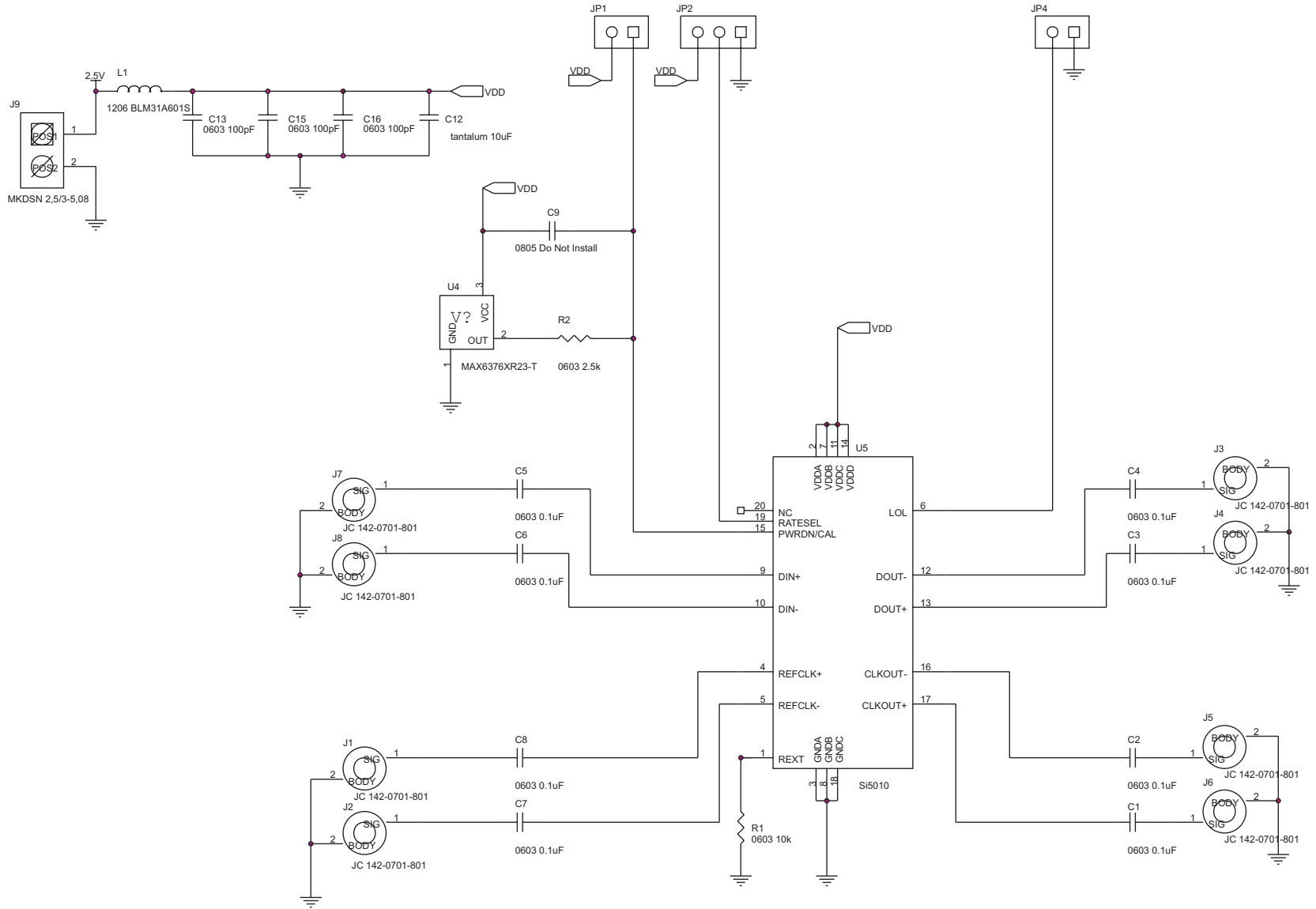

Figure 3. Si5010 Schematic

Si5010-EVB

Bill of Materials

Si5010EVB Assy Rev B-02 BOM			
Reference	Part Desc	Part Number	Manufacturer
C1,C2,C3,C4,C5, C6,C7,C8	CAP, SM, 0.1uF, 0603	C0603X7R160-104KNE	Venkel
C12	CAP, SM, 10 uF, TANTALUM, 3216	TA010TCM106KAR	Venkel
C13,C15,C16	CAP, SM, 100 pF, 16V, 0603	C0603C0G500101KNE	Venkel
JP1,JP4	CONNECTOR, HEADER, 2X1	2340-6111TN or 2380-6121TN	3M
JP2	CONNECTOR, HEADER, 3X1	2340-6111TN or 2380-6121TN	3M
J1,J2,J3,J4,J5,J6, J7,J8	CONNECTOR, SMA, SIDE MOUNT	901-10003	Amphenol
J9	CONNECTOR, POWER, 2 POS	1729018	Phoenix Contact
L1	RESISTOR, SM, 0 OHM, 1206	CR1206-8W-000T	Venkel
R1	RESISTOR, SM, 10K, 1%, 0603	CR0603-16W-1002FT	Venkel
R2	RESISTOR, SM, 2.55K, 1%, 0603	CR0603-16W-2551FT	Venkel
U4	MAX6376XR23-T	MAX6376XR23-T	Maxim
U5	Si5010	SI5010-BM	Silicon Laboratories
PCB	PRINTED CIRCUIT BOARD	SI5010-EVB PCB Rev C	Silicon Laboratories
No Load			
C9	SPARE,0805		

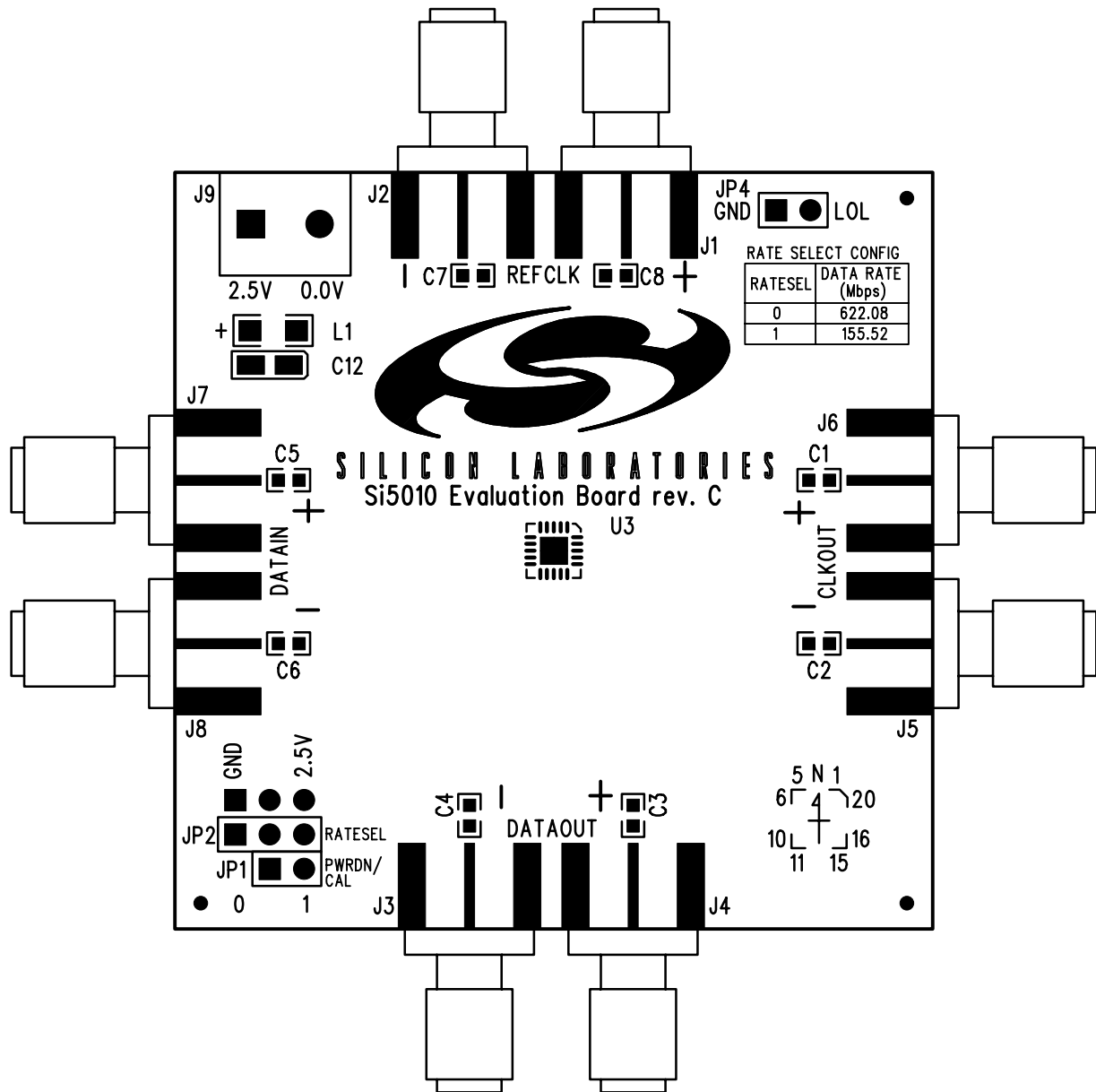

Figure 4. Si5010 Silkscreen

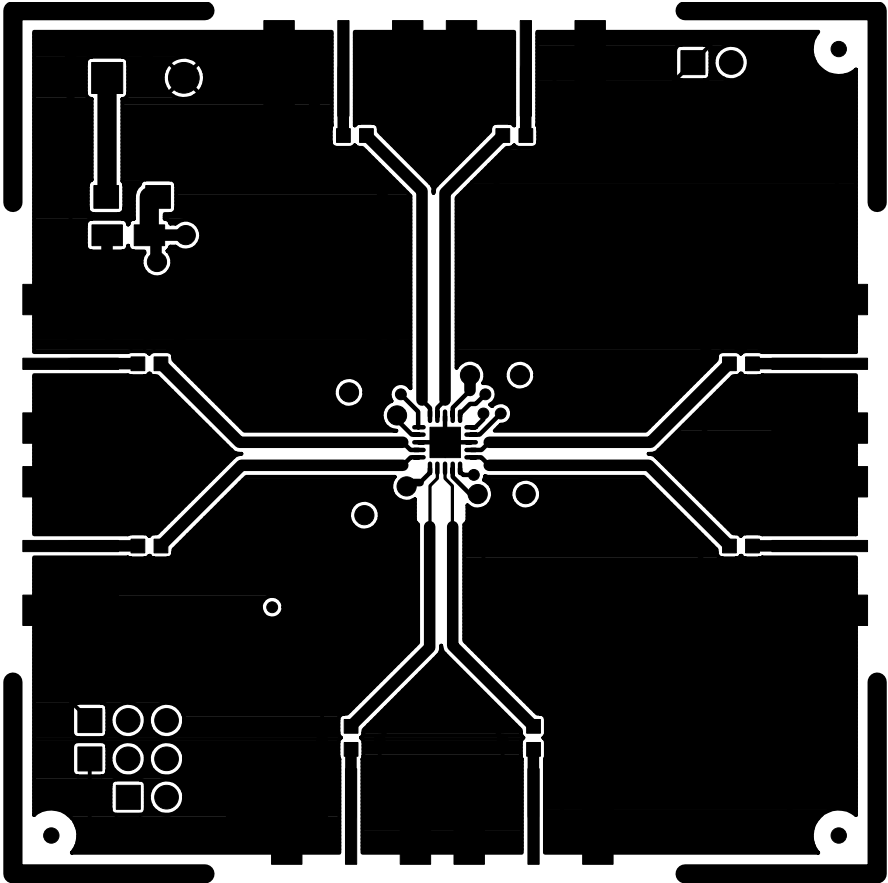

Figure 5. Si5010 Component Side

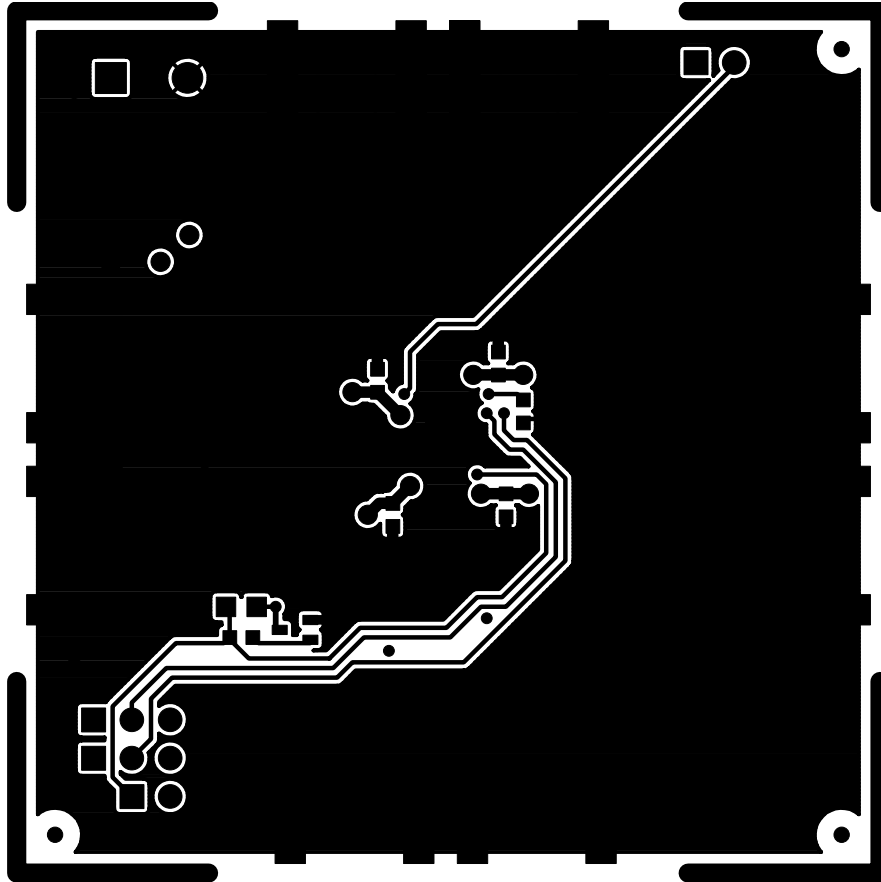

Figure 6. Si5010 Solder Side

Si5010-EVB

Document Change List

Revision 0.41 to Revision 1.0

- “Preliminary” language removed.

Evaluation Board Assembly Revision History

Assembly Level	PCB	Si5010 Device	Assembly Notes
B-01	B	B	Assemble per BOM rev B-01.
B-02	C	B	Assemble per BOM rev B-02.

Notes:

Contact Information

Silicon Laboratories Inc.
4635 Boston Lane
Austin, TX 78735
Tel: 1+(512) 416-8500
Fax: 1+(512) 416-9669
Toll Free: 1+(877) 444-3032
Email: productinfo@silabs.com
Internet: www.silabs.com

The information in this document is believed to be accurate in all respects at the time of publication but is subject to change without notice. Silicon Laboratories assumes no responsibility for errors and omissions, and disclaims responsibility for any consequences resulting from the use of information included herein. Additionally, Silicon Laboratories assumes no responsibility for the functioning of undescribed features or parameters. Silicon Laboratories reserves the right to make changes without further notice. Silicon Laboratories makes no warranty, representation or guarantee regarding the suitability of its products for any particular purpose, nor does Silicon Laboratories assume any liability arising out of the application or use of any product or circuit, and specifically disclaims any and all liability, including without limitation consequential or incidental damages. Silicon Laboratories products are not designed, intended, or authorized for use in applications intended to support or sustain life, or for any other application in which the failure of the Silicon Laboratories product could create a situation where personal injury or death may occur. Should Buyer purchase or use Silicon Laboratories products for any such unintended or unauthorized application, Buyer shall indemnify and hold Silicon Laboratories harmless against all claims and damages.

Silicon Laboratories, Silicon Labs, and SiPHY are trademarks of Silicon Laboratories Inc.

Other products or brandnames mentioned herein are trademarks or registered trademarks of their respective holders.