

Data Sheet / GP-735

Easy to Use,

Slim,

Ultra High Performance,

GPS

Smart Antenna Module

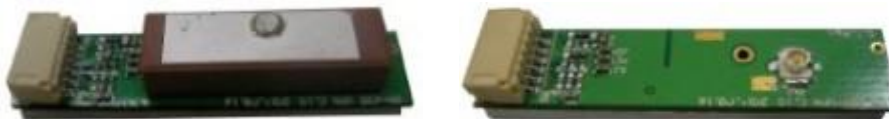

RoHS
Compliant

Version 1.0

The specifications in this document are subject to change without prior notice. ADH Technology Co. Ltd. assumes no warranties (either expressed or implied) regarding the accuracy and completeness of this document and shall in no event be liable for any loss of profit or any other commercial damage, including but not limited to special, incidental, consequential, or other damages. ADH-tech products are not intended for use in medical, life-support devices, commercial aircraft or any applications involving potential risk of personal injury, death, or severe property damage in case of failure of the product.

No part of this document may be reproduced or transmitted in any form by any means without the express written permission of ADH Technology Co. Ltd.

Revision History

Ver.	Date	Description
1.0	June. 5 th , 2014	Initial draft

Contents

1	INTRODUCTION.....	1
1.1	OVERVIEW	1
1.2	MAIN FEATURES.....	1
1.3	RECEIVER SPECIFICATIONS	1
1.4	PROTOCOLS.....	2
2	HARDWARE INTERFACE	3
2.1	MODULE DIMENSION	3
2.2	PIN ASSIGNMENT	4
3	SOFTWARE INTERFACE	6
3.1	NMEA OUTPUT MESSAGES.....	6
3.2	GPGGA - GLOBAL POSITIONING SYSTEM FIX DATA.....	7
3.3	GPGLL - GEOGRAPHIC POSITION - LATITUDE / LONGITUDE	7
3.4	GPGSA - GNSS DOP AND ACTIVE SATELLITES	8
3.5	GPGSV - GNSS SATELLITES IN VIEW.....	8
3.6	GPRMC - RECOMMENDED MINIMUM SPECIFIC GNSS DATA.....	9
3.7	GPVTG - COURSE OVER GROUND AND GROUND SPEED.....	9
4	EVALUATION INFORMATION.....	11
4.1	OVERVIEW	11
4.2	ORDERING INFORMATION	12
4.3	TIPS IN DESIGNING	錯誤! 尚未定義書籤。
5	ELECTRICAL AND ENVIRONMENTAL DATA	144

1 Introduction

1.1 Overview

ADH-tech GP-735 is a slim, ultra-high performance, easy to use GPS smart antenna module designed with u-blox's latest 7th generation single chip.

This feature rich GPS module not only shortens the design efforts but also provides powerful functions. The compact design allows fast adoption and high yield production.

The power control feature is very convenient to turn on/off power just via GPIO control pin. It's especially useful to turn off power as the GPS function is not needed in the host applications.

1.2 Main Features

Not only handheld but also any other GPS applications can share the following major features of GP-735.

- ◆ Easy adoption with best performance
- ◆ Built-in narrow patch antenna for dimension demanding application
- ◆ Models of I-PEX RF connector option available for using external antenna
- ◆ Built-in backup power pin for faster position fix
- ◆ USB/UART-TTL interface support
- ◆ Minimum RF and EMI efforts
- ◆ Fully implementation of ultra-high performance u-blox7 single chip architecture
- ◆ High tracking sensitivity of -162 dBm!
- ◆ Low power consumption of 37mA for average tracking
- ◆ Hardware power saving control pin allowing power on/off GPS via GPIO
- ◆ Windows location sensor support
- ◆ A-GPS support

1.3 Receiver Specifications

Features	Specifications ¹
GPS receiver type	56 channels, L1 frequency, C/A code

Horizontal Position Accuracy	< 2.5m (Autonomous) < 2.0m (WAAS) (CEP, 50%, 24hr static, -130dBm)
Velocity Accuracy	<0.1 m/s (speed) <0.5° (heading) (50%@30m/s)
Accuracy of Time pulse Signal	30ns (RMS) or <60 ns (99%)
TTF (Time to First Fix) (50%, -130dBm, autonomous)	Hot Start: 1s Warm Start: 28s Cold Start: 29s
Sensitivity (Autonomous)	Tracking: -162dBm Acquisition: -148dBm
Measurement data output	Update rate: 1 Hz (default), up to 10 Hz by enabling command NMEA output protocol: Ver. 2.3 (compatible to 3.0) UART baud rate: 9600 bps, (N-8-1) Datum: WGS-84 Default: GGA, GLL, GSA, GSV, RMC, VTG, TXT
Max. Altitude	< 50,000 m
Max. Velocity	< 1,852 km/hr
SBAS Support	WAAS, EGNOS, MSAS, GAGAN
Dynamics	< 4g
Power consumption	37mA, continuous tracking mode
Power supply	3.1 ~ 5.5 V (TTL); 4.75~5.25V (USB)
Dimension	8(W) x 35(L) x 6.55(H) (mm)
Operating temperature	-40°C ~ +85°C
Storage temperature	-40°C ~ +85°C

¹ **Note. According to IC Spec**

1.4 Protocols

The NMEA protocol is supported via serial UART (RX/TX) or USB (DM/DP) I/O port. The default supported protocol is NMEA protocol.

1. Serial communication channel – UART
 - i. No parity, 8-data bit, 1-stop bit (N-8-1)
 - ii. 4800, 9600, 38400(default), 57600 bps.
2. NMEA 0183 Version 2.3 ASCII output
 - i. Default GGA, GSA, GSV, GLL, RMC, VTG and TXT

2 Hardware Interface

2.1 Module Dimension

The dimension of GP-735 with patch antenna is 8(W) x 35(L) x 6.55(H) (mm).

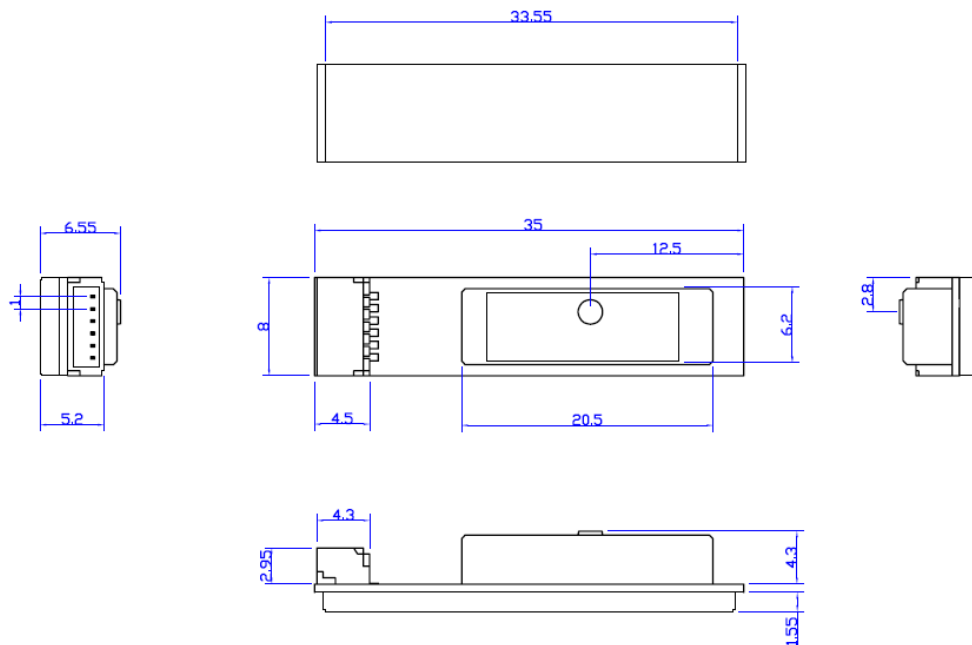

Unit:mm
Tolerance:±0.25mm

The dimension of GP-735 with I-PEX connector is 8(W) x 35(L) x 5.2(H) (mm).



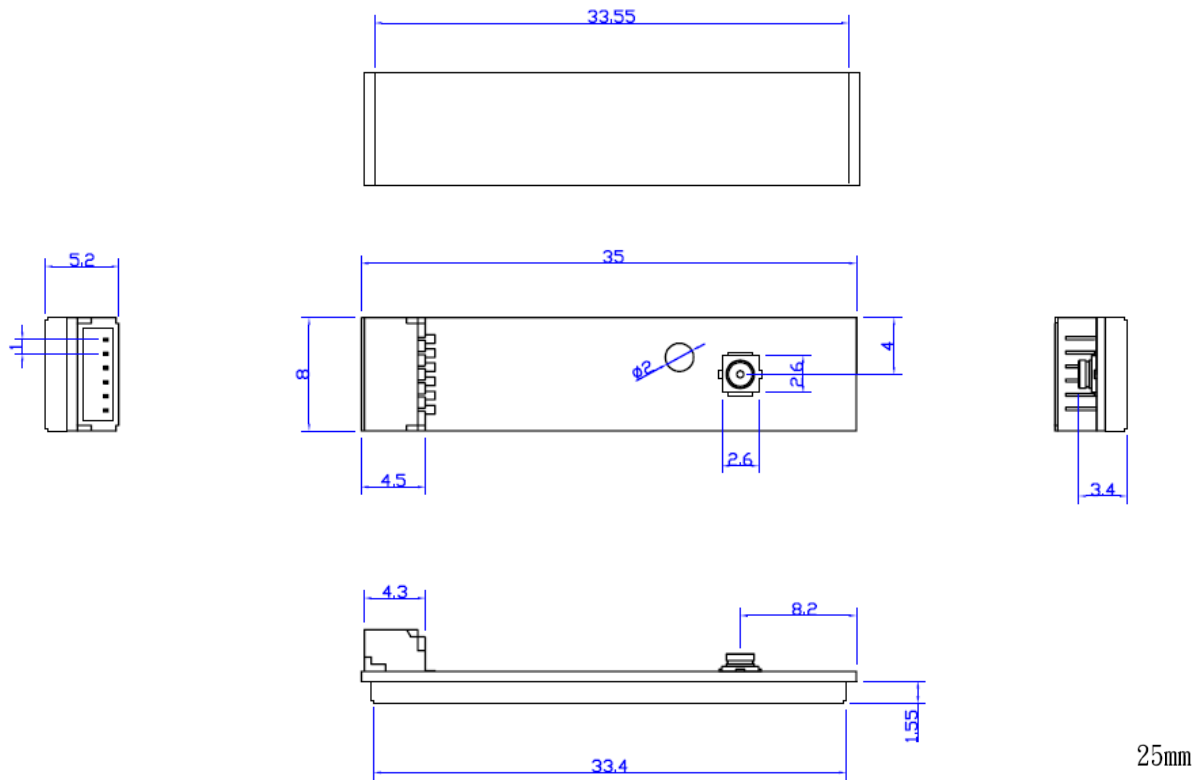

2.2 Pin Assignment

6-pin Interface, pitch 1.0mm, USB

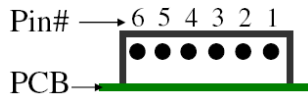

Pin	Name	Function	I/O
1	GND	Ground	Input
2	VCC	4.75 ~ 5.25 V power supply	Input
3	DP	USB positive	I/O
4	DM	USB negative	I/O
5	V_BAT	Backup power (1.5 ~ 3.5V)	Input
6	PWR_CTRL	Module power control High or disconnected: power ON Low: power OFF	Input

6-pin Interface, pitch 1.0mm, UART TTL

Pin	Name	Function	I/O
1	GND	Ground	Input
2	VCC	3.1 ~ 5.5 V power supply	Input

3	TXA	Port A serial data output (from GPS)	Output
4	RXA	Port A serial data input (to GPS)	Input
5	V_BAT	Backup power (1.5 ~ 3.5V)	Input
6	PWR_CTRL	Module power control High or disconnected: power ON Low: power OFF	Input

Power Saving

GP-735 supports the easy power saving control mechanism via a GPIO pin. To control the power of GP-735, connect the **PWR_CTRL** pin to a GPIO of micro-processor. To cut off the power of GP-735 (VCC is always connected to power source), just pull the PWR_CTRL pin low (in this case, GP-735 only keeps power of RTC and RAM). During normal run, pull it high or leave it floating (in this case, GP-735 is fully powered).

3 Software Interface

3.1 NMEA Output Messages

The NMEA-0183 Output Messages are shown as below:

NMEA Record	Descriptions
GPGGA	Global positioning system fixed data: time, position, fixed type
GPGLL	Geographic position: latitude, longitude, UTC time of position fix and status
GPGSA	GPS receiver operating mode, active satellites, and DOP values
GPGSV	GNSS satellites in view: ID number, elevation, azimuth, and SNR values
GPRMC	Recommended minimum specific GNSS data: time, date, position, course, speed
GPVTG	Course over ground and ground speed
GPTXT	u-blox message

The GP-735 adopts interface protocol of National Marine Electronics Association's NMEA-0183 Version 2.3 interface specification. GP-735 supports 7 types of NMEA sentences (GPGGA, GPGLL, GPGSA, GPGSV, GPRMC, GPVTG, and GPTXT).

The default output sentences are GPGGA, GPGSA, GPGSV, GPRMC, GPVTG and GPGLL. The default UART communication parameters are 9600 bps, 8 data bits, 1 stop bit, and no parity. Other baud rate and related configurations could be requested based on MOQ.

The message examples below:

```
$GPRMC,065500.00,A,2447.65027,N,12100.78318,E,15.869,189.32,051109,,D*57
$GPVTG,189.32,T,,M,15.869,N,29.405,K,D*30
$GPGGA,065500.00,2447.65027,N,12100.78318,E,2,12,0.91,69.8,M,16.3,M,,*65
$GPGSA,A,3,20,02,23,13,50,42,04,11,17,28,32,08,1.53,0.91,1.22*0D
$GPGSV,4,1,13,02,10,252,26,04,39,268,40,08,09,197,41,11,17,058,32*7B
$GPGSV,4,2,13,13,06,144,23,17,50,345,43,20,45,056,44,23,11,109,37*72
$GPGSV,4,3,13,27,02,301,,28,73,194,39,32,20,043,38,42,54,140,34*7B
$GPGSV,4,4,13,50,51,133,33*4B
$GPGLL,2447.65027,N,12100.78318,E,065500.00,A,D*6E
$GPTXT,01,01,02,u-blox ag - www.u-blox.com*50
```

3.2 GPGGA - Global Positioning System Fix Data

- Example

\$GPGGA,065500.00,2447.65027,N,12100.78318,E,2,12,0.91,69.8,M,16.3,M,,*65

- Explanation

Contents	Example	Unit	Explanation
Message ID	\$GPGGA		GGA protocol header
UTC Time	065500.00		hhmmss.ss hh: hour, mm: minute, ss: second
Latitude	2447.65027		ddmm.mmmmm dd: degree, mm.mmmmm: minute
North/South	N		N: North Latitude, S: South Latitude
Longitude	12100.78318		dddmm.mmmmm dd: degree, mm.mmmmm: minute
East/West	E		E: East Longitude, W: West Longitude
Position Fix Indicator	2		0: Fix not available or invalid, 1: GPS SPS Mode, fix valid, 2: Differential GPS, SPS Mode, fix valid, 3~5: Not supported, 6: Dead Reckoning Mode, fix valid
Satellites Used	12		Number of satellites used in positioning calculation (0 to 12)
HDOP	0.91		Horizontal Dilution of Precision
MSL Altitude	69.8	meters	
Unit	M		Meters
Geoidal separation	16.3	meters	
Units	M		Meters
Age of Diff. Corr.		second	Null fields when DGPS is not used
Diff. Ref. Station ID			
checksum	*65		
<CR><LF>			End of sentence

3.3 GPGLL - Geographic Position - Latitude / Longitude

- Example

\$GPGLL,2447.65027,N,12100.78318,E,065500.00,A,D*6E

- Explanation

Contents	Example	Unit	Explanation
Message ID	\$GPGLL		GLL protocol header
Latitude	2447.65027		ddmm.mmmmm dd: degree, mm.mmmmm: minute
North/South	N		N: North Latitude, S: South Latitude
Longitude	12100.78318		dddmm.mmmmm dd: degree, mm.mmmmm: minute
East/West	E		E: East Longitude, W: West Longitude
UTC Time	065500.00		hhmmss.ss hh: hour, mm: minute, ss: second
Status	A		A: Data valid, V: Data invalid
Mode Indicator	D		A: Autonomous, D: DGPS, E: DR
checksum	*6E		

<CR><LF>		End of sentence
----------	--	-----------------

3.4 GPGSA - GNSS DOP and Active Satellites

■ Example

\$GPGSA,A,3,20,02,23,13,50,42,04,11,17,28,32,08,1.53,0.91,1.22*0D

■ Explanation

Contents	Example	Explanation
Message ID	\$GPGSA	GSA protocol header
Mode 1	A	M: Manual—forced to operate in 2D or 3D mode A: 2D Automatic—allowed to automatically switch 2D/3D
Mode 2	3	1: Fix not available 2: 2D (<= 4 Satellites used) 3: 3D (>= 4 Satellites used)
Satellite used in solution	20	Satellite on Channel 1
Satellite used in solution	02	Satellite on Channel 2
...		Display of quantity used (12 max) If less than 12 SVs are used for navigation, the remaining fields are left empty. If more than 12 SVs are used for navigation, only the IDs of the first 12 are output.
PDOP	1.53	Position Dilution of Precision
HDOP	0.91	Horizontal Dilution of Precision
VDOP	1.22	Vertical Dilution of Precision
checksum	*0D	
<CR><LF>		End of sentence

3.5 GPGSV - GNSS Satellites in View

■ Example

\$GPGSV,4,1,13,02,10,252,26,04,39,268,40,08,09,197,41,11,17,058,32*7B

\$GPGSV,4,2,13,13,06,144,23,17,50,345,43,20,45,056,44,23,11,109,37*72

\$GPGSV,4,3,13,27,02,301,,28,73,194,39,32,20,043,38,42,54,140,34*7B

\$GPGSV,4,4,13,50,51,133,33*4B

■ Explanation

Contents	Example	Unit	Explanation
Message ID	\$GPGSV		GSV protocol header
Number of messages	4		Range 1 to 4
Message number	1		Range 1 to 4
Satellites in view	13		Number of satellites visible from receiver
Satellite ID number	02		Channel 2 (Range 1 to 64) The satellite ID numbers are in the range of 1 to 32 for GPS satellites, and 33 to 64 for SBAS satellites (ID=120-PRN; e.g. SV ID 33 is SBAS PRN 120, 34 is SBAS PRN 121, and so on)
Elevation	10	degrees	Elevation angle of satellite as seen from receiver channel 1 (00 to 90)
Azimuth	252	degrees	Satellite azimuth as seen from receiver channel 1 (000 to 359)
SNR (C/No)	26	dBHz	Received signal level C/No from receiver

			channel 1 (00 to 99, null when not tracking)
...			
Satellite ID number	11		Channel 4 (Range 1 to 32)
Elevation	17	degrees	Elevation angle of satellite as seen from receiver channel 4 (00 to 90)
Azimuth	058	degrees	Satellite azimuth as seen from receiver channel 4 (000 to 359)
SNR (C/No)	32	dBHz	Received signal level C/No from receiver channel 4 (00 to 99, null when not tracking)
checksum	*71		
<CR><LF>			End of sentence

3.6 GPRMC - Recommended Minimum Specific GNSS Data

- Example

\$GPRMC,065500.00,A,2447.65027,N,12100.78318,E,15.869,189.32,051109,,D*57

- Explanation

Contents	Example	Unit	Explanation
Message ID	\$GPRMC		RMC protocol header
UTC Time	065500.00		hhmmss.ss hh: hour, mm: minute, ss: second
Status	A		A: Data valid, V: Data invalid
Latitude	2447.65027		ddmm.mmmmm dd: degree, mm.mmmmm: minute
North/South	N		N: North Latitude, S: South Latitude
Longitude	12100.78318		dddmm.mmmmm dd: degree, mm.mmmmm: minute
East/West	E		E: East Longitude, W: West Longitude
Speed over ground	15.869	knots	Receiver's speed
Course over ground	189.32	degrees	Receiver's direction of travel Moving clockwise starting at due north
Date	051109		ddmmyy dd: Day, mm: Month, yy: Year
Magnetic variation		degrees	This receiver does not support magnetic declination. All "course over ground" data are geodetic WGS84 directions.
Mode Indicator	D		A: Autonomous M: Manual D: DGPS S: Simulation E: Dead Reckoning N: Data Invalid
checksum	*57		
<CR><LF>			End of sentence

3.7 GPVTG - Course over Ground and Ground Speed

- Example

\$GPVTG,189.32,T,,M,15.869,N,29.405,K,D*30

- Explanation

Contents	Example	Unit	Explanation
Message ID	\$GPVTG		VTG protocol header
Course over ground	189.32	degrees	Receiver's direction of travel Moving clockwise starting at due north (geodetic WGS84 directions)
Reference	T		True

Course over ground		degrees	Receiver's direction of travel
Reference	M		Magnetic
Speed over ground	15.869	knots	Measured horizontal speed
Unit	N		Knots
Speed over ground	29.405	km/hr	Measured horizontal speed
Unit	K		km/hr
Mode Indicator	D		A: Autonomous, D: DGPS, E: DR
checksum	*30		
<CR><LF>			End of sentence

4 Evaluation Information

4.1 Overview

Following figure shows the GP-735 EVK (evaluation kit). It contains EVB (evaluation board), a 6-pin to 6-pin cable between GP-735 and EVB, and a USB cable from EVB to PC.



Large ground plane below GP-735 boots its performance. As shown in following picture, GP-735 mounts on top of EVB and the shielding case of GP-735 is soldered to the ground plane of EVB. GP-735 should face up to the sky.

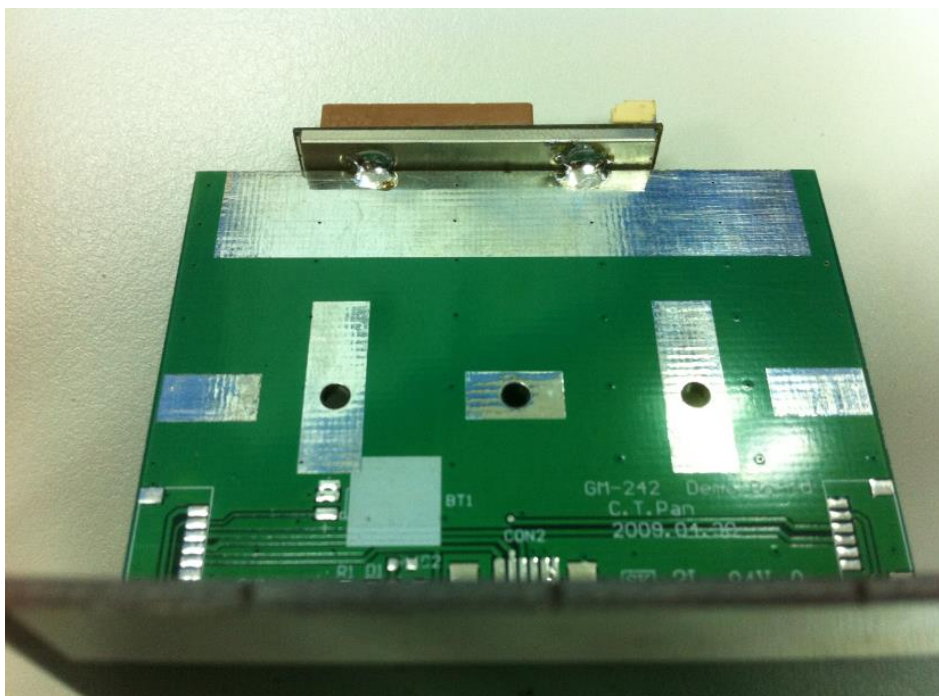

It's easy to connect the 6-pin I/O connector and USB cable for checking the performance or doing power saving control.

4.2 Ordering Information

GP-735X

- Models with built-in **patch antenna**

X=	Description
U	USB interface, patch antenna GGA, GLL, GSA, GSV, RMC, VTG, TXT @1Hz
T	UART interface, 38400bps, N-8-1, patch antenna GGA, GLL, GSA, GSV, RMC, VTG, TXT @1Hz



- Models with **I-PEX RF connector** for external antenna

X=	Description
I	UART interface, 38400bps, N-8-1, I-PEX for external passive antenna GGA, GLL, GSA, GSV, RMC, VTG, TXT @1Hz
J	UART interface, 38400bps, N-8-1, I-PEX for external active antenna GGA, GLL, GSA, GSV, RMC, VTG, TXT @1Hz
K	USB interface, I-PEX for external passive antenna GGA, GLL, GSA, GSV, RMC, VTG, TXT @1Hz
L	USB interface, I-PEX for external active antenna GGA, GLL, GSA, GSV, RMC, VTG, TXT @1Hz



In addition to above models, options of different baud rates are also available.

Please contact our sales window directly or email to sales@adh-tech.com.tw if any customization is needed.

4.3 Tips in Designing

The GPS signal is pretty low, less than -130 dBm, which is easily interfered by the EMI of

application circuit, and its central frequency, 1.575 GHz might be shifted due to the housing material of host.

Interference checking

1. Check the signal reception status of GPS module standalone with a GPS viewer tool.
2. Compare it when it is placed at the planned location on the application board.
3. Please find better location or adjust the application to reduce the interference if it affects the GPS receiving sensitivity.

Antenna working frequency checking

1. Compare the GPS sensitivity with and without host's housing.
2. If the GPS signal is degraded significantly, the GPS antenna needs to fine tune to match the housing material to achieve the optimum central frequency and field pattern.
3. Please note that there is MOQ request for antenna customization.

5 Electrical and Environmental Data

Electrical Data

Power Supply (VDC)	3.1 ~ 5.5 (TTL); 4.75~5.25 (USB)
Power Consumption (w/o antenna)	37mA/average tracking
Backup power	1.5 ~ 3.5 V
USB I/O (V)	VIH: 2.0 ~ VDD_USB (VDD_USB: 3.3V) VIL: 0 ~ 0.8 VOH >= 2.8 VOL <= 0.3
Digital I/O (V)	VIH: 0.7*VDD_IO ~ VDD_IO (VDD_IO: 3.3V) VIL 0 ~ 0.2*VDD_IO VOH >= VDD_IO-0.4V VOL <= 0.4
Protocols	NMEA (default)

Environmental Data

Operating temperature	-40 ~ 85°C
Storage temperature	-40 ~ 85°C
Vibration	5Hz to 500Hz, 5g
Shock	Half sine 30g/11ms
RoHS compliant	Yes