

Si80xx THREE TO SIX CHANNEL DIGITAL ISOLATOR EVALUATION BOARD USER'S GUIDE

1. Introduction

The Si80xx evaluation kit allows designers to evaluate Skyworks Solutions' family of low-power digital isolators. These are CMOS devices offering substantial data rate, propagation delay, power, size, reliability, and external BOM advantages over legacy isolation technologies. The operating parameters of these products remain stable across wide temperature ranges and throughout device service life for ease of design and highly uniform performance. All device versions have Schmitt trigger inputs for high noise immunity and only require VDD bypass capacitors. Data rates up to 10 Mbps are supported, and all devices achieve propagation delays of less than 65 ns. Enable inputs provide a single point control for enabling and disabling output drive. Ordering options include a choice of 1kV_{RMS} isolation ratings. For more information, refer to the Si80xx family data sheets. This evaluation kit consists of an evaluation board featuring the QSOP-16 package. Note that the other packages are not available at this time.

1.1. Kit Contents

The Si80xx Evaluation Kit contains the following items:

- Si80xx based evaluation board as shown in Figures 1.
- Si80xx Digital isolator (installed on the evaluation board)
 - Si8065 (QSOP-16)

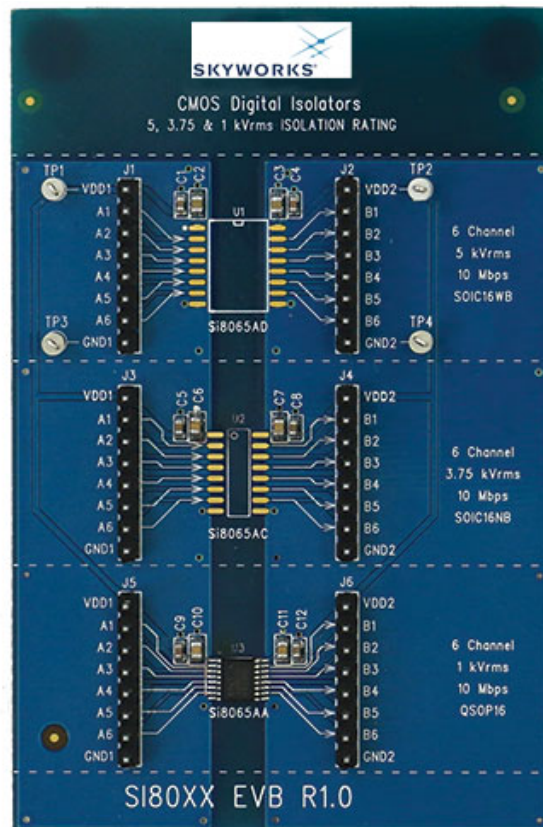

Figure 1. Si80xx Evaluation Board Overview

2. Required Equipment

The following items are required to demonstrate the evaluation board:

- 1 digital multimeter
- 2 multimeter test leads (red and black)
- 1 oscilloscope (Tektronix TDS 2024B or equivalent)
- 1 BNC splitter
- 4 coaxial cables
- 2 dc power supply (HP6024A, 30 V dc, 0–100 mA or equivalent)
- 2 BNC to clip converters (red and black)
- 4 Banana to clip wires (2 red and 2 black)
- 1 function generator (Agilent 33220A, 20 MHz or equivalent)
- Si80xx Evaluation Board (board under test)
- Si80xx Digital Isolator Input Evaluation Board User's Guide (this document)

3. Hardware Overview and Demo

Figure 2 illustrates the connection diagram used to demonstrate the Si80xx-EVB. This demo transmits a 500 kHz (5 V peak, 50 percent duty cycle) square wave through the isolator to its output. In this example, VDD1 and VDD2 are powered by 5 V supplies. Figure 3 shows a scope shot of CH1 (input) and CH2 (output). Note that if a user wants to evaluate a digital isolator other than the ones pre-populated, this can be accomplished by removing the installed device and replacing it with the desired footprint-compatible isolator device.

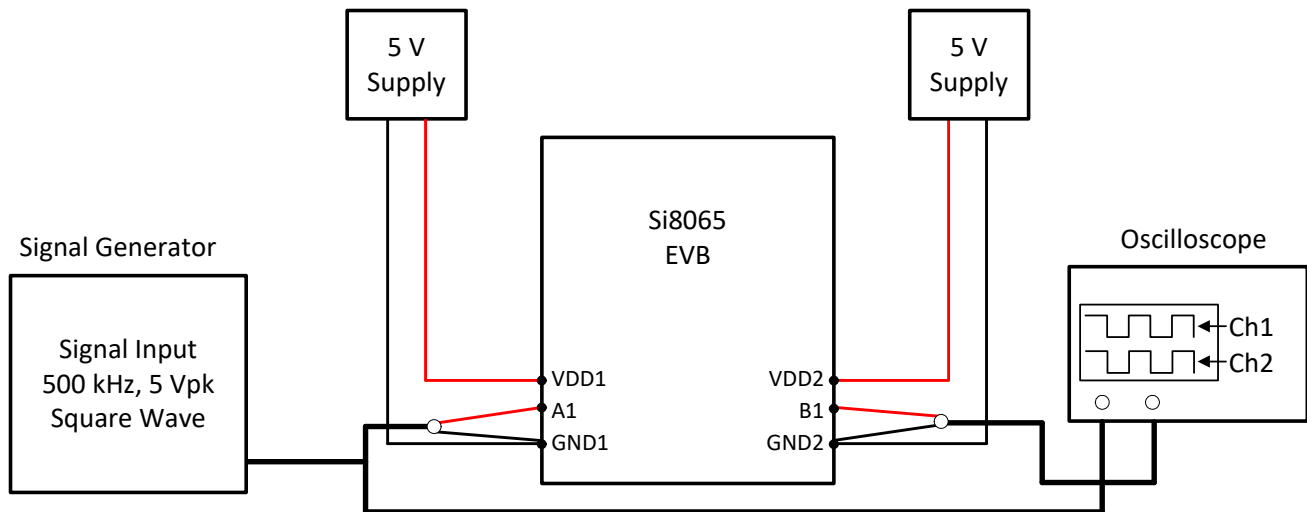

Figure 2. Summary Diagram and Demo Setup

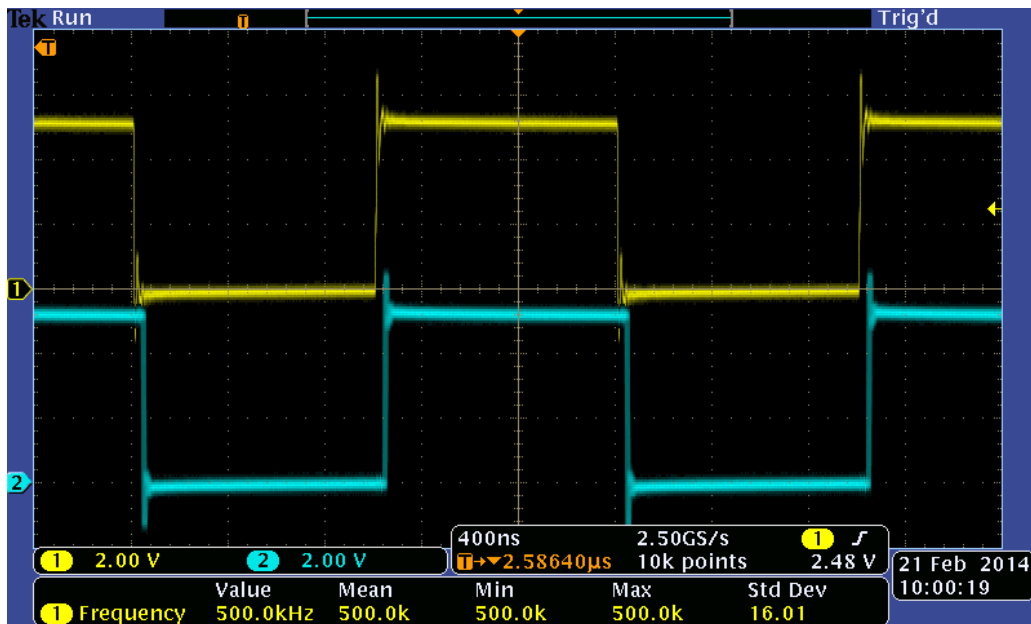

Figure 3. Oscilloscope Display of Input and Output

Si80xx-EVB

3.1. DC Supply Configuration

To run the demo, follow the instructions below. Review Figure 2 and Figure 5 if necessary.

1. Turn OFF the dc power supply and ensure that the output voltage is set to its lowest output voltage.
2. Connect the banana ends of the black and red banana-to-clip terminated wires to the outputs of both dc supplies.
3. For the input side of the Si80xx-EVB, connect the clip end of the red banana-to-clip terminated wire to VDD1 and the clip end of the black wire to GND1.
4. Similarly, for the output side of the EVB, the red wire goes to VDD2 and the black wire goes to GND2.
5. Turn ON the dc power supply and adjust both dc power supplies to provide 5 V on their outputs.
6. Ensure that the current draw is less than 25 mA. If it is larger, this indicates that either the board or Si80xx has been damaged or the supply is connected backwards.

3.2. Wave Form Generator

1. Turn ON the arbitrary waveform generator with the output disengaged.
2. Adjust its output to provide a 500 kHz, 0 to 5 V peak square wave (50 percent duty cycle) to its output.
3. Connect one end of the first coaxial cable to the output of the signal generator.
4. Connect the BNC splitter to the other end of the first coaxial cable.
5. From the BNC splitter, connect the second coaxial cable to CH1 of the scope. CH1 will display the input to the EVB.
6. Connect the third coaxial cable to the BNC splitter, and connect a BNC-to-clip converter to the end of this coaxial cable.
7. From here, connect the clip end of the BNC-to-clip converter to the Si80xx-EVB's A1 (red wire here) and GND1 (black wire here).
8. Connect one end of the fourth coaxial cable to a BNC-to-clip converter (note that a scope probe can be used here instead).
9. From here, connect the clip end of the BNC-to-clip converter to the Si80xx-EVB's B1 (red wire here) and GND2 (black wire here).
10. Connect the other end of the fourth coaxial cable to CH2 of the oscilloscope. CH2 will display the output of the EVB.
11. Engage the output of the waveform generator.

3.3. Oscilloscope Setup

1. Turn ON the oscilloscope.
2. Set the scope to Trigger on CH1 and adjust the trigger level to 1 V minimum.
3. Set CH1 and CH2 to 2 V per division.
4. Adjust the seconds/division setting to 400 ns/division.
5. Adjust the level indicator for all channels to properly view each channel as shown in Figure 3.

A 500 kHz square wave should display on Channel 1 of the scope for the input and a 5 V delayed version of this square wave should display the output on Channel 2, as shown in Figure 3. This concludes the basic demo.

4. Hardware and Overview Setup

The board is designed to be powered from two separate supplies VDD1, VDD2 that can be independently varied from 3.15 to 5.5 V. Figure 4 shows a silkscreen overview of the board and Figure 5 shows the board schematic.

The power and jumper connection descriptions are summarized here:

- J1/3/5 Stake headers used to power and connect to the digital isolator's Side1 pins.
- J2/4/6 Stake headers used to power and connect to the digital isolator's Side 2 pins.
- TP1/2/3/4 Test Points that can also be used to provide VDD and GND.

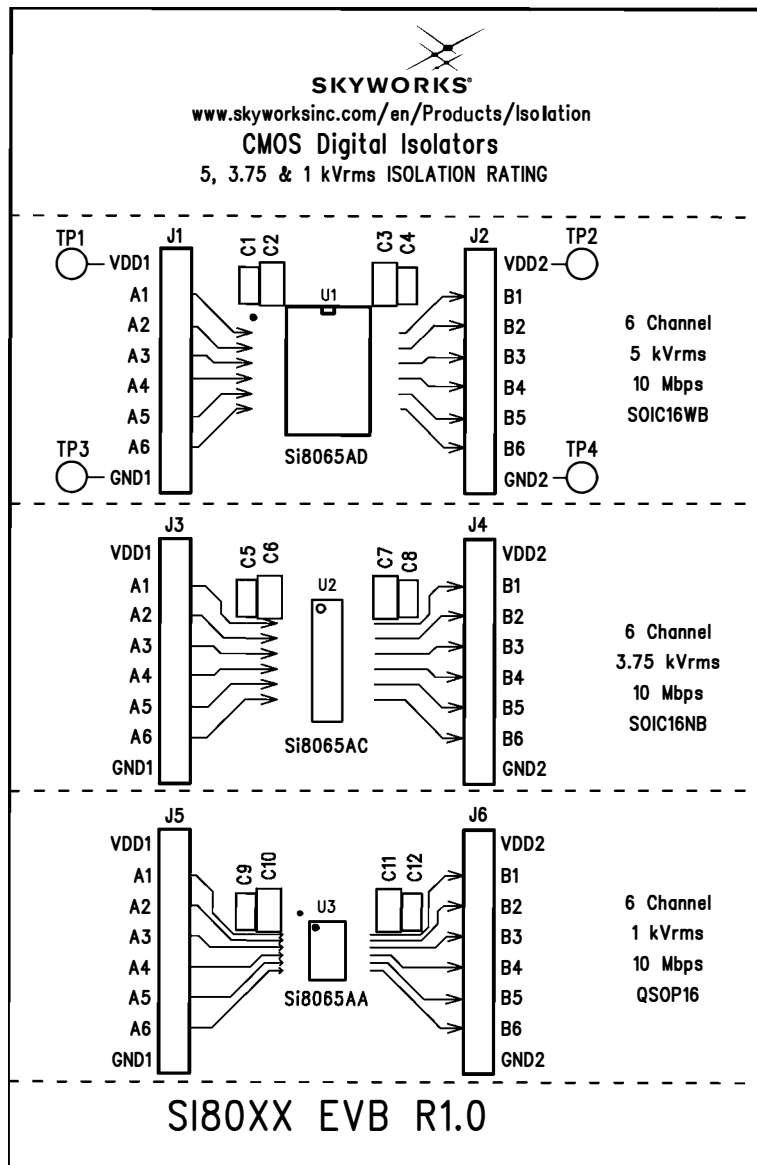

Figure 4. Si80xx DIP8 Evaluation Board Silkscreen

Si80xx-EVB

5. Si80xx Evaluation Board Schematics

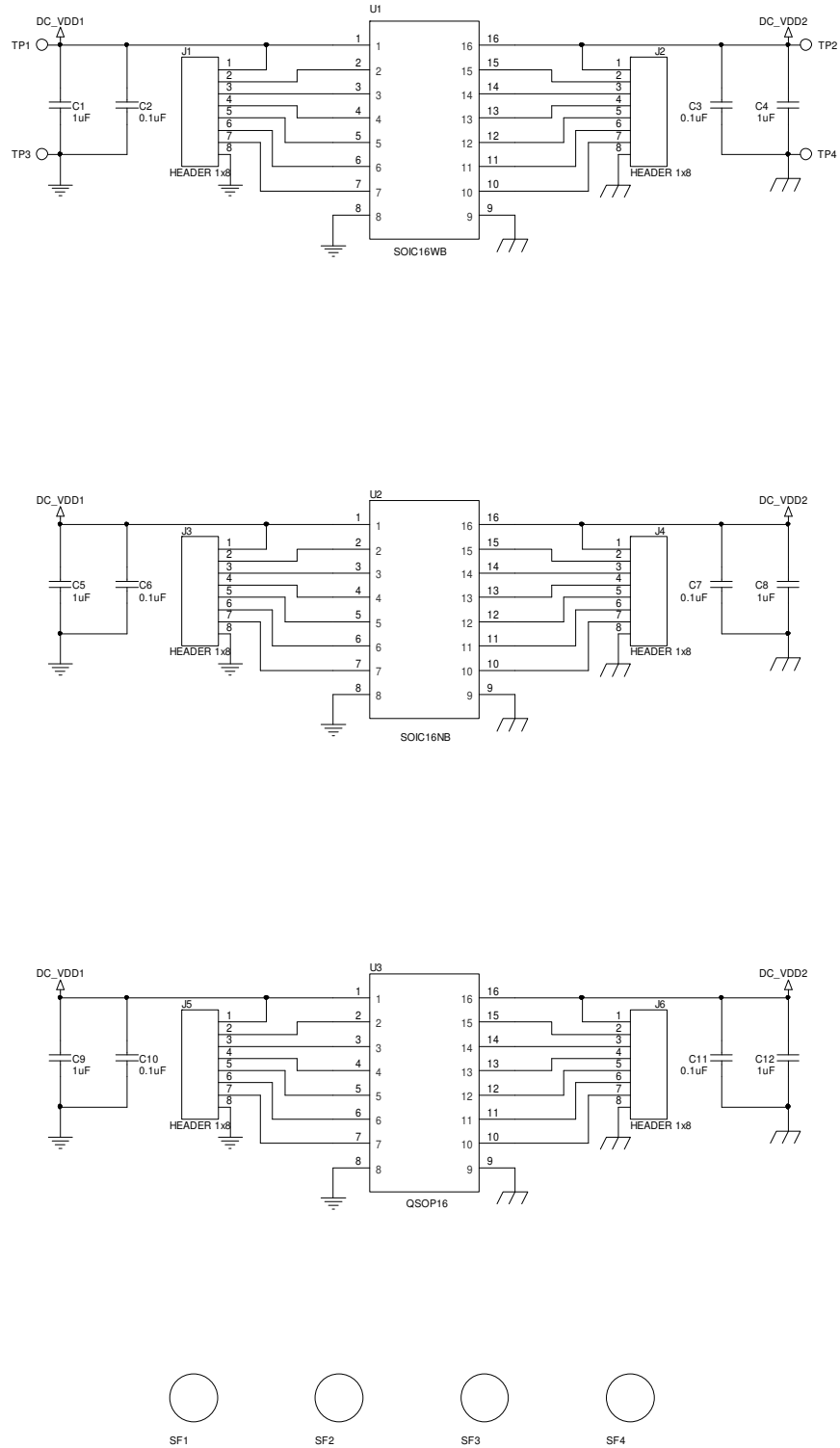

Figure 5. Si80xx Evaluation Board Schematic

6. Bill of Materials

Table 1. Si80xx Evaluation Board Bill of Materials

Item	Qty	Ref	Part #	Supplier	Description	Value
1	6	C1, C4, C5, C8, C9, C12	C0603X5R250-105K	Venkel	CAP, 1 μ F, 25 V, \pm 10%, X5R, 0603	1 μ F
2	6	C2, C3, C6, C7, C10, C11	C0805X7R101-104K	Venkel	CAP, 0.1 μ F, 100 V, \pm 10%, X7R, 0805	0.1 μ F
3	6	J1, J2, J3, J4, J5, J6	TSW-108-07-T-S	Samtec	Header, 1x8, 0.1in pitch, tin plated	HEADER 1x8
4	4	SF1, SF2, SF3, SF4	SJ61A6	3M	HDW, Bumpon cylindrical 312X.215 BLK	Bumper
5	4	TP1, TP2, TP3, TP4	151-201-RC	Kobiconn	Testpoint, White, PTH	White
6	1	U1	Si8065AD-B-IS (not installed)	Skyworks	IC, three to six-channel digital isolators, SOIC16WB	SOIC16WB
7	1	U2	Si8065AC-B-IS1 (not installed)	Skyworks	IC, three to six-channel digital isolators, SOIC16NB	SOIC16NB
8	1	U3	Si8065AA-B-IU	Skyworks	IC, isolator, 6 I/O, QSOP16	QSOP16

Si80xx-EVB

7. Ordering Guide

Table 2. Si80xx Evaluation Board Ordering Guide

Ordering Part Number (OPN)	Description
Si80xx-KIT	Si80xx Isolator Evaluation Board Kit



SKYWORKS®

**Connecting Everyone
and Everything,
All the Time**



Portfolio

www.skyworksinc.com

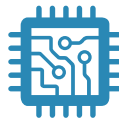

Quality

www.skyworksinc.com/quality



Support & Resources

www.skyworksinc.com/support

Copyright © 2021 Skyworks Solutions, Inc. All Rights Reserved.

Information in this document is provided in connection with Skyworks Solutions, Inc. ("Skyworks") products or services. These materials, including the information contained herein, are provided by Skyworks as a service to its customers and may be used for informational purposes only by the customer. Skyworks assumes no responsibility for errors or omissions in these materials or the information contained herein. Skyworks may change its documentation, products, services, specifications or product descriptions at any time, without notice. Skyworks makes no commitment to update the materials or information and shall have no responsibility whatsoever for conflicts, incompatibilities, or other difficulties arising from any future changes.

No license, whether express, implied, by estoppel or otherwise, is granted to any intellectual property rights by this document. Skyworks assumes no liability for any materials, products or information provided hereunder, including the sale, distribution, reproduction or use of Skyworks products, information or materials, except as may be provided in Skyworks' Terms and Conditions of Sale.

THE MATERIALS, PRODUCTS AND INFORMATION ARE PROVIDED "AS IS" WITHOUT WARRANTY OF ANY KIND, WHETHER EXPRESS, IMPLIED, STATUTORY, OR OTHERWISE, INCLUDING FITNESS FOR A PARTICULAR PURPOSE OR USE, MERCHANTABILITY, PERFORMANCE, QUALITY OR NON-INFRINGEMENT OF ANY INTELLECTUAL PROPERTY RIGHT; ALL SUCH WARRANTIES ARE HEREBY EXPRESSLY DISCLAIMED. SKYWORKS DOES NOT WARRANT THE ACCURACY OR COMPLETENESS OF THE INFORMATION, TEXT, GRAPHICS OR OTHER ITEMS CONTAINED WITHIN THESE MATERIALS. SKYWORKS SHALL NOT BE LIABLE FOR ANY DAMAGES, INCLUDING BUT NOT LIMITED TO ANY SPECIAL, INDIRECT, INCIDENTAL, STATUTORY, OR CONSEQUENTIAL DAMAGES, INCLUDING WITHOUT LIMITATION, LOST REVENUES OR LOST PROFITS THAT MAY RESULT FROM THE USE OF THE MATERIALS OR INFORMATION, WHETHER OR NOT THE RECIPIENT OF MATERIALS HAS BEEN ADVISED OF THE POSSIBILITY OF SUCH DAMAGE.

Skyworks products are not intended for use in medical, lifesaving or life-sustaining applications, or other equipment in which the failure of the Skyworks products could lead to personal injury, death, physical or environmental damage. Skyworks customers using or selling Skyworks products for use in such applications do so at their own risk and agree to fully indemnify Skyworks for any damages resulting from such improper use or sale.

Customers are responsible for their products and applications using Skyworks products, which may deviate from published specifications as a result of design defects, errors, or operation of products outside of published parameters or design specifications. Customers should include design and operating safeguards to minimize these and other risks. Skyworks assumes no liability for applications assistance, customer product design, or damage to any equipment resulting from the use of Skyworks products outside of Skyworks' published specifications or parameters.

Skyworks, the Skyworks symbol, Sky5®, SkyOne®, SkyBlue™, Skyworks Green™, Clockbuilder®, DSPLL®, ISOModem®, ProSLIC®, and SiPHY® are trademarks or registered trademarks of Skyworks Solutions, Inc. or its subsidiaries in the United States and other countries. Third-party brands and names are for identification purposes only and are the property of their respective owners. Additional information, including relevant terms and conditions, posted at www.skyworksinc.com, are incorporated by reference.

Skyworks Solutions, Inc. | Nasdaq: SWKS | sales@skyworksinc.com | www.skyworksinc.com

USA: 781-376-3000 | Asia: 886-2-2735 0399 | Europe: 33 (0)1 43548540 | [in](https://www.linkedin.com/company/skyworks) [f](https://www.facebook.com/skyworks) [t](https://twitter.com/skyworks) [y](https://www.youtube.com/skyworks)