

NON-ROHS COMPLIANT VERSION

LOC	DIST	REVISIONS			
AD	00	REV	DESCRIPTION	DATE	BY
		D2	ECO-07-03605	15FEB07	MB JO

- NOTES :
- MATERIAL**
INSERT: PBT, BLACK, UL94V-0 RATED
CONTACT & JACKSCREWS: BRASS
SHELLS & SHIELD: STEEL
ENCLOSURE: PVC, BLACK
 - FINISH**
CONTACT: GOLD PLATING 0.02µm[.0000008] MIN ON CONTACT AREA 2.3µm[.000090] MIN TIN-LEAD PLATING ON SOLDER AREA. ALL OVER 1.27µm[.000050] MIN NICKEL.
SHELL: 2.4µm[.000095] MIN TIN
SHIELD: 2.0-3.0µm[.000080-.000120] TIN
 - SPECIFICATION**
ELECTRICAL CHARACTERISTICS:
CURRENT RATING: 3 AMPERES
DIELECTRIC WITHSTANDING VOLTAGE: AC 1000V r.m.s
INSULATION RESISTANCE: 5000 MEGOHMS MINIMUM AT DC 500V
CONTACT RESISTANCE: 10 MILLIOHMS MAXIMUM.
 - RECEPTACLE CONNECTOR FULLY LOADED WITH CONTACTS. ALL OTHER PARTS ARE SHIPPED UNASSEMBLED, EACH PART INDIVIDUALLY BULK PACKED.
 - SOLDER CUP WILL ACCOMMODATE 20 MAX AWG WIRE.
 - FINISH**
CONTACT: GOLD PLATING 0.02µm[.0000008] MIN ON CONTACT AREA 2.3µm[.000090] MIN TIN PLATING ON SOLDER AREA. ALL OVER 1.27µm[.000050] MIN NICKEL.
SHELL: 2.4µm[.000095] MIN TIN
SHIELD: 2.0-3.0µm[.000080-.000120] TIN
 - ROHS 2002/95/EC COMPLIANT PART. (SEE SHEET 2).

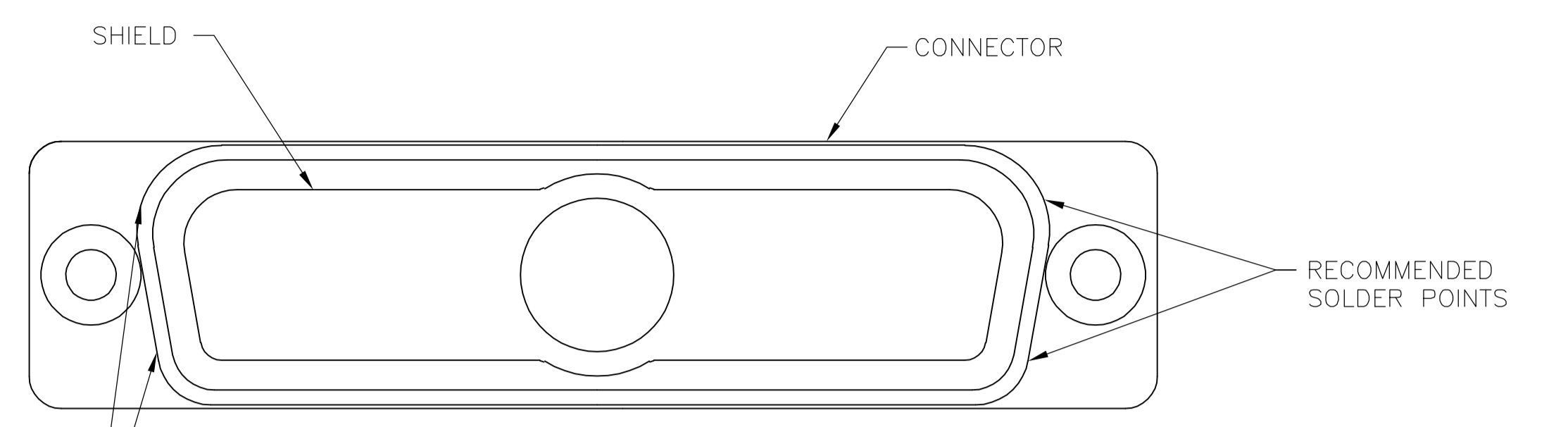
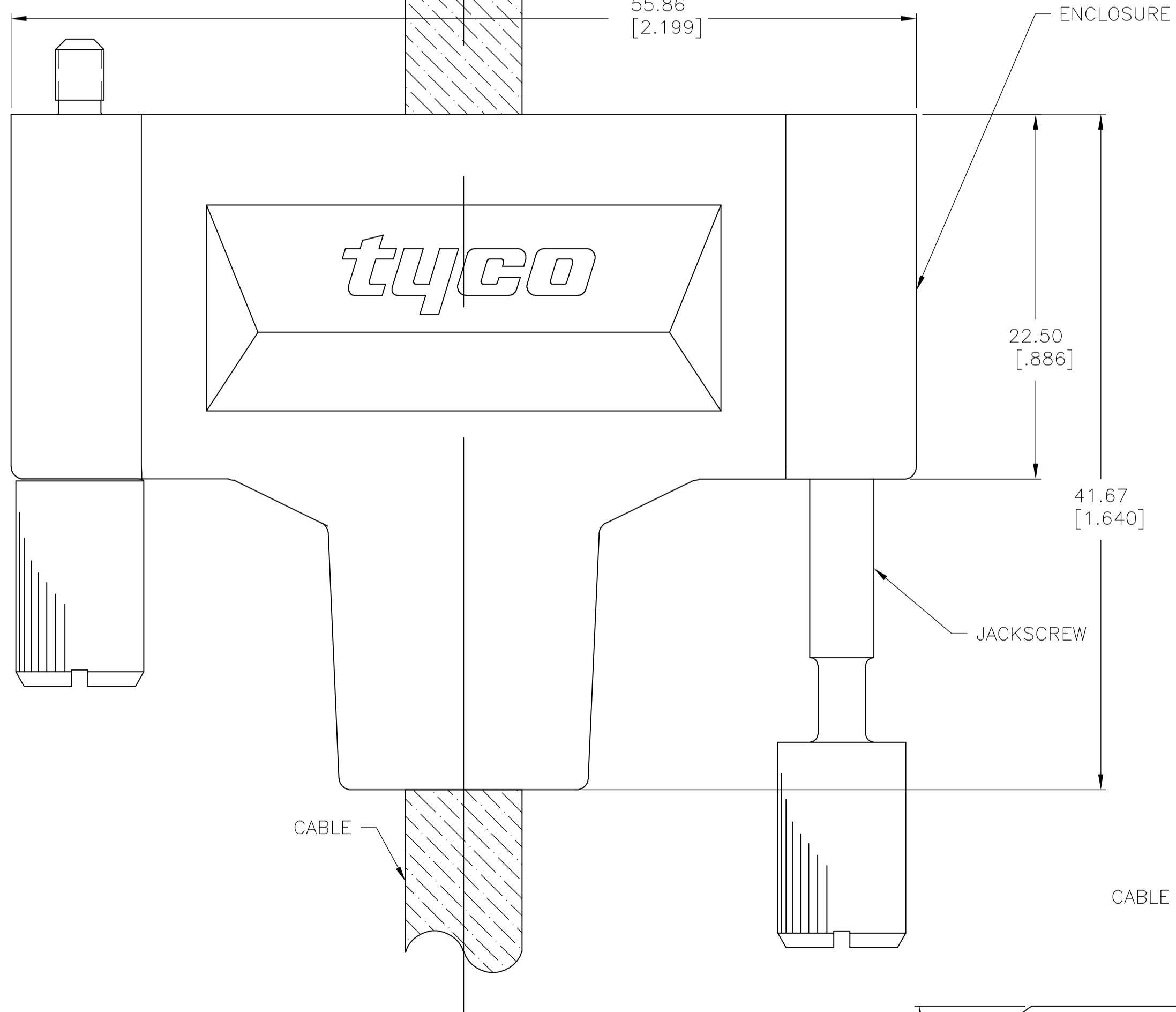
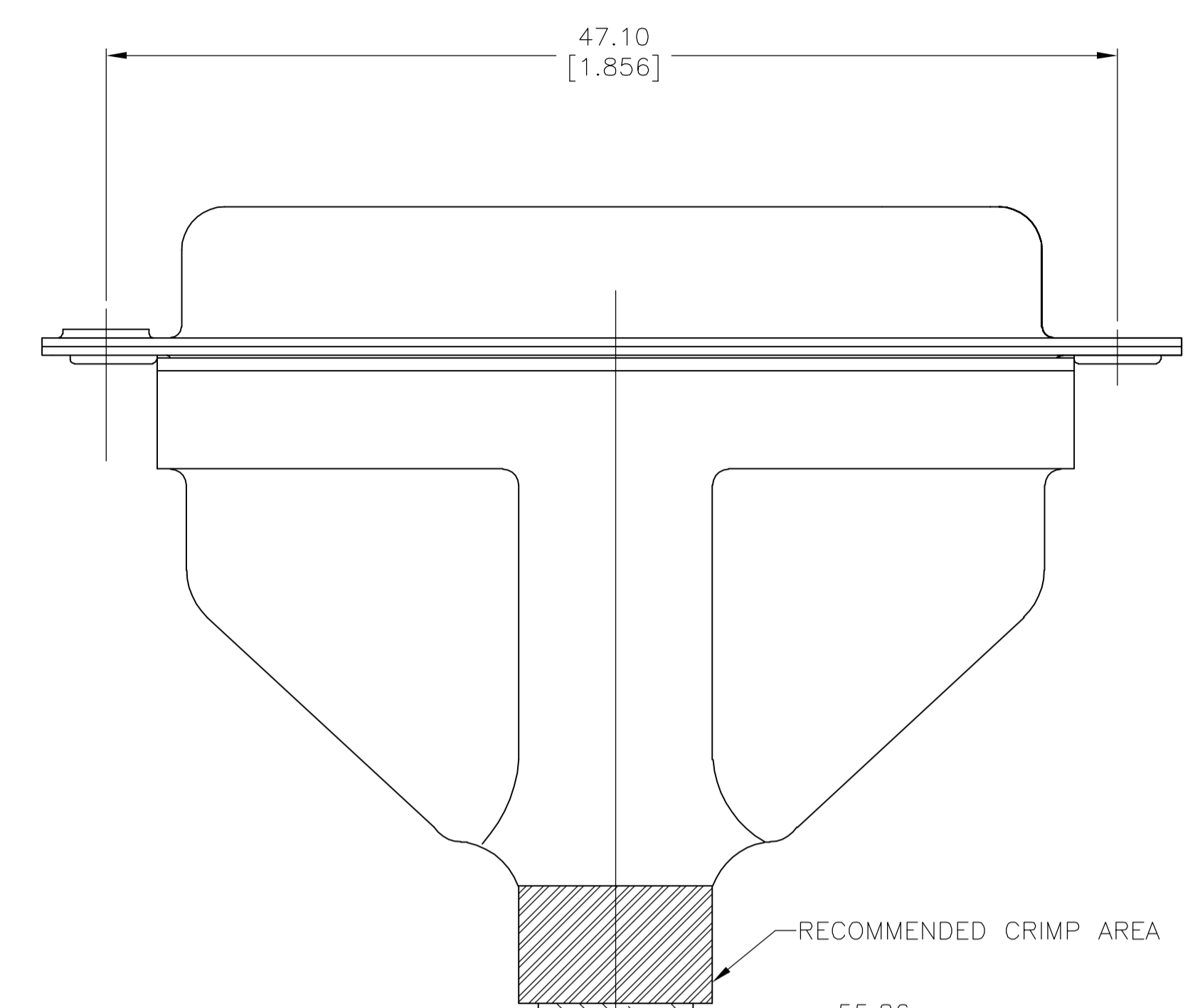

SOLDER LOCATION (OPTIONAL)

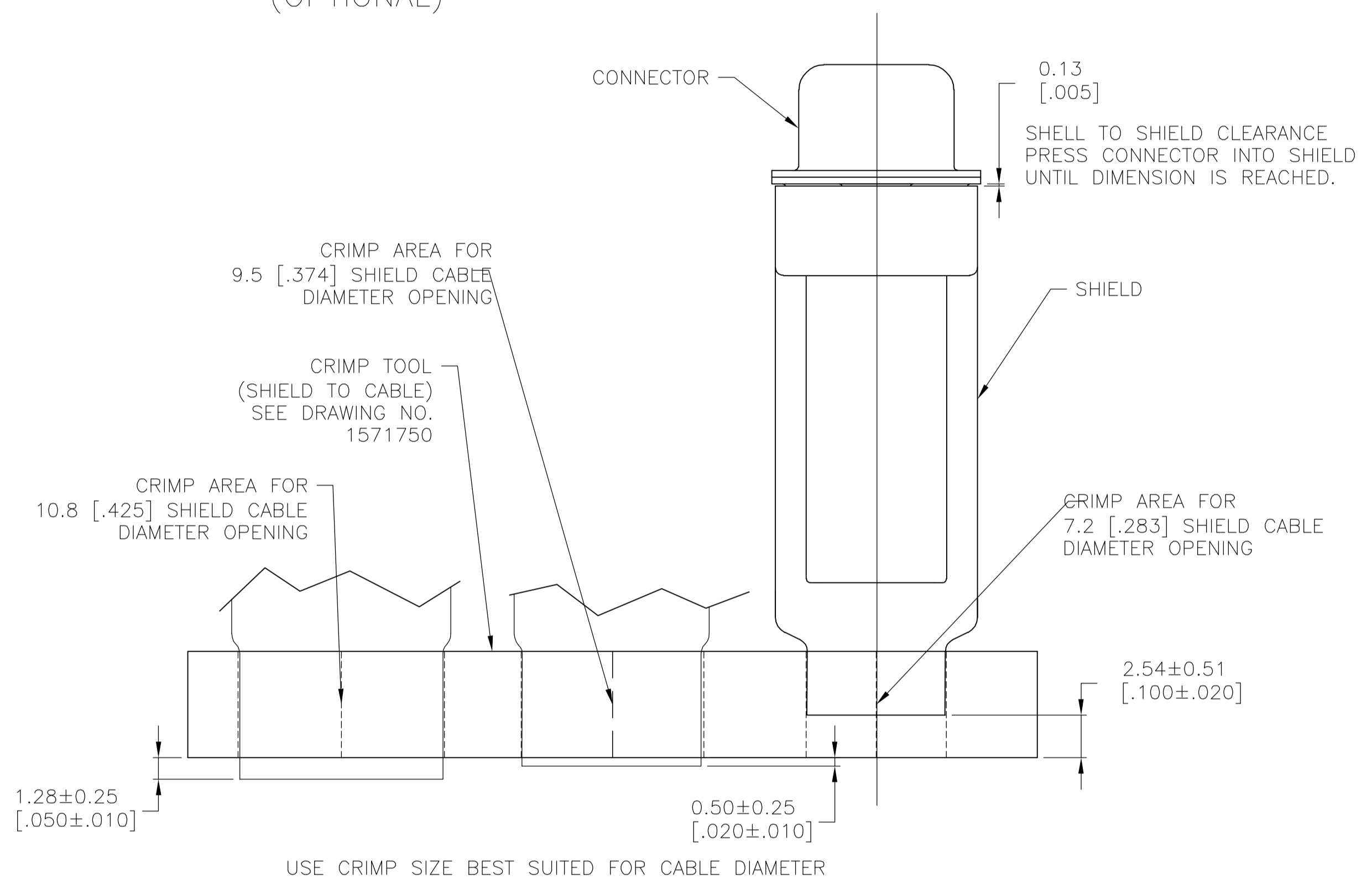

SHIELD TO CABLE CRIMP

ASSEMBLY INSTRUCTIONS

- USE SHIELD ENCLOSURE EXPANSION TOOL, 58241-1 TO GET ENCLOSURE ON CABLE.
- PREPARE CABLE AS SHOWN.
- PLACE CABLE THROUGH SHIELD.
- SOLDER CONDUCTORS TO CONTACTS.
- PRESS SHIELD ONTO CONNECTOR AS SHOWN.
- SOLDER SHIELD TO CONNECTOR AS SHOWN (OPTIONAL).
- METALLIC SHIELD SURFACES AND INTERIOR ENCLOSURE SURFACE MUST BE CLEAN AND DRY PER 3M REQUIREMENTS.
- CUT TWO PIECES OF 3M/SCOTCH VHB 4926, DOUBLE COATED ADHESIVE TAPE 6 TO 8mm WIDE BY 31 TO 35mm LONG.
- APPLY TAPE TO METALLIC SHIELD SURFACE. LENGTHWISE. ADJACENT TO CONNECTOR FLANGE.
- REMOVE ADHESIVE BACKING FROM TAPE AND PUSH ENCLOSURE OVER METALLIC SHIELD.
- BOND STRENGTH IS DEPENDANT ON THE AMOUNT OF SURFACE CONTACT DEVELOPED. A FIRM APPLICATION DEVELOPS A BETTER BOND. ULTIMATE SURFACE CONTACT CAN BE ACCOMPLISHED BY CLAMPING ENCLOSURE TO THE SHIELD. CARE SHOULD BE TAKEN NOT TO MAR THE POLYMER SURFACE. SHIMS MAY BE REQUIRED TO EVENLY DISTRIBUTE THE CLAMPING FORCE ACROSS THE POLYMER.
- ULTIMATE BOND STRENGTH IS DEVELOPED AFTER 72 HOURS, BUT MAY BE ACCELERATED BY EXPOSURE TO 66°C FOR 1 HOUR, IF THE CLAMPS ARE COMPATIBLE WITH THIS TEMPERATURE.
- INSERT JACK SCREWS.

EXPLODED VIEW OF ASSEMBLED KIT

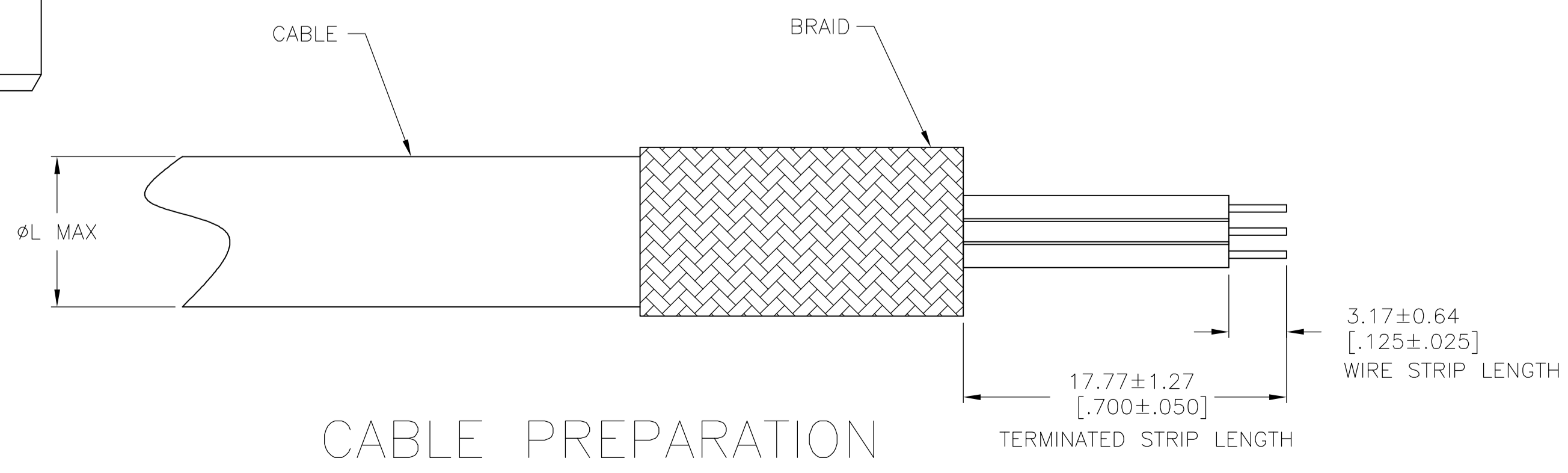

CABLE PREPARATION

REV	DESCRIPTION	DATE	BY
8	10.8 [.425]	1571656-6	
8	9.5 [.374]	1571656-5	
8	7.2 [.283]	1571656-4	
	10.8 [.425]	1571656-3	
	9.5 [.374]	1571656-2	
	7.2 [.283]	1571656-1	
	FINISH	CABLE DIA	PART NUMBER

THIS DRAWING IS A CONTROLLED DOCUMENT.		DIN M. BINNER 21NOV03	tyco Tyco Electronics Corporation Harrisburg, Pa 17105-3608	
DIMENSIONS: mm [NCHES]	TOLERANCES UNLESS OTHERWISE SPECIFIED:	APVD	NAME	BULK KIT, RECEPTACLE, AMPLIMITE SOLDER CUP SHIELDING ENCLOSURE 25 POSITION, SIZE 3
0 PLC ±	1 PLC ± 0.3[.012]		PRODUCT SPEC	108-40031
2 PLC ±	3 PLC ±		APPLICATION SPEC	
4 PLC ±	ANGLES ±		SIZE	CAGE CODE DRAWING NO
MATERIAL	FINISH	WEIGHT	A1 00779	1571656
		CUSTOMER DRAWING	SCALE 4:1	SHEET 1 OF 2 REV D2

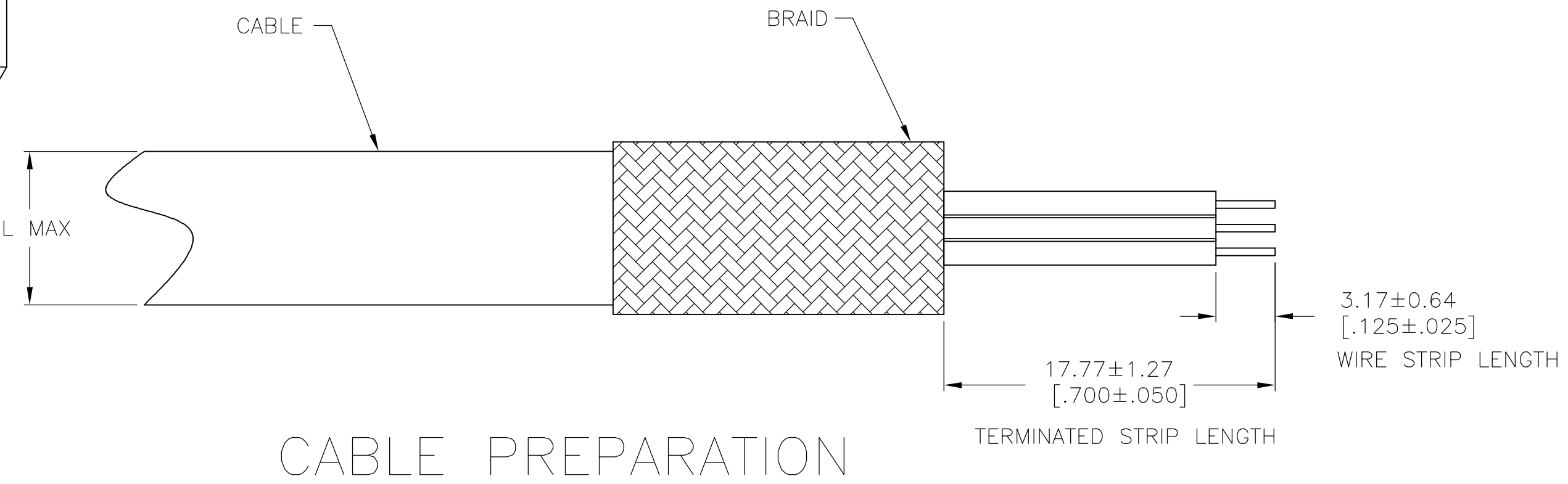
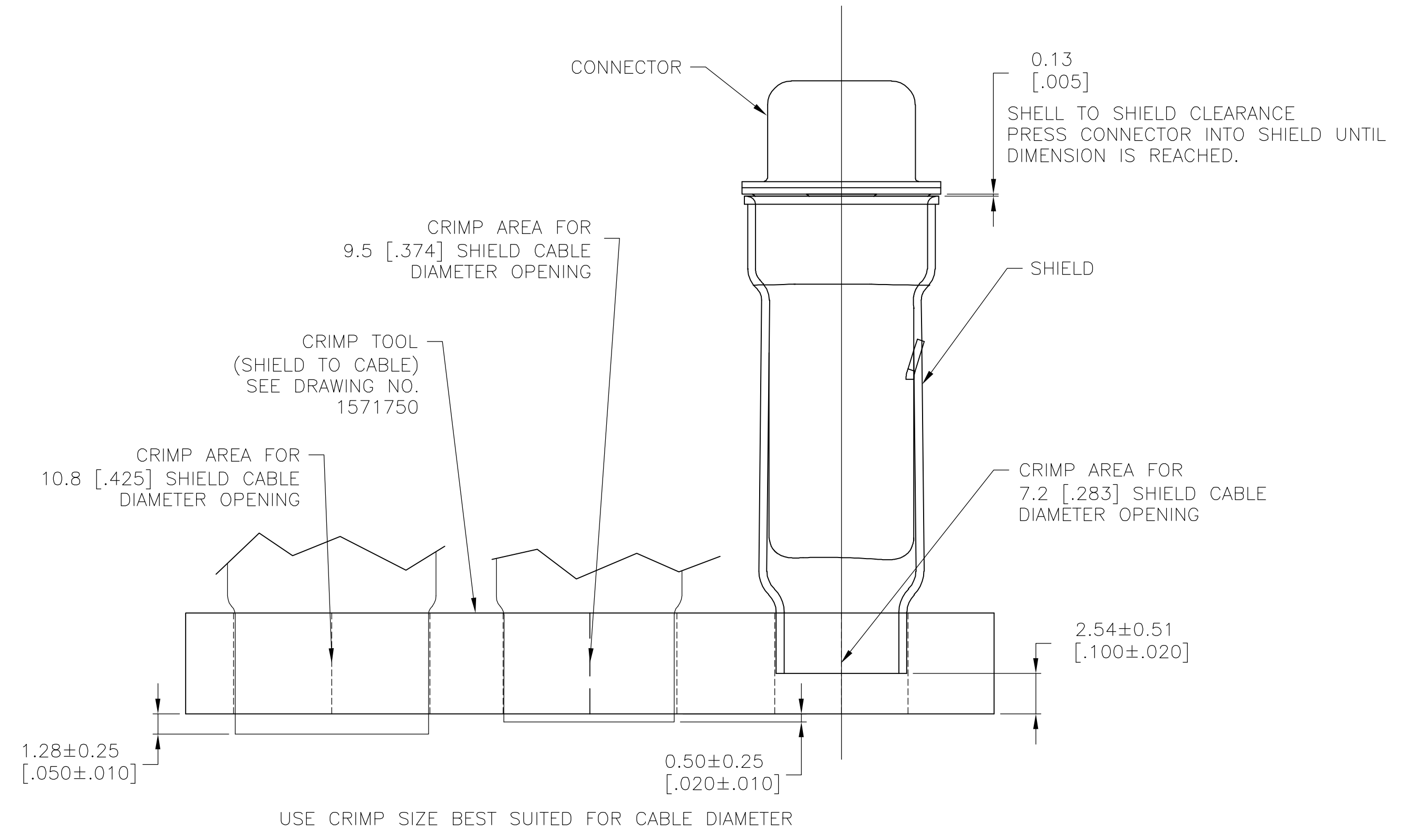
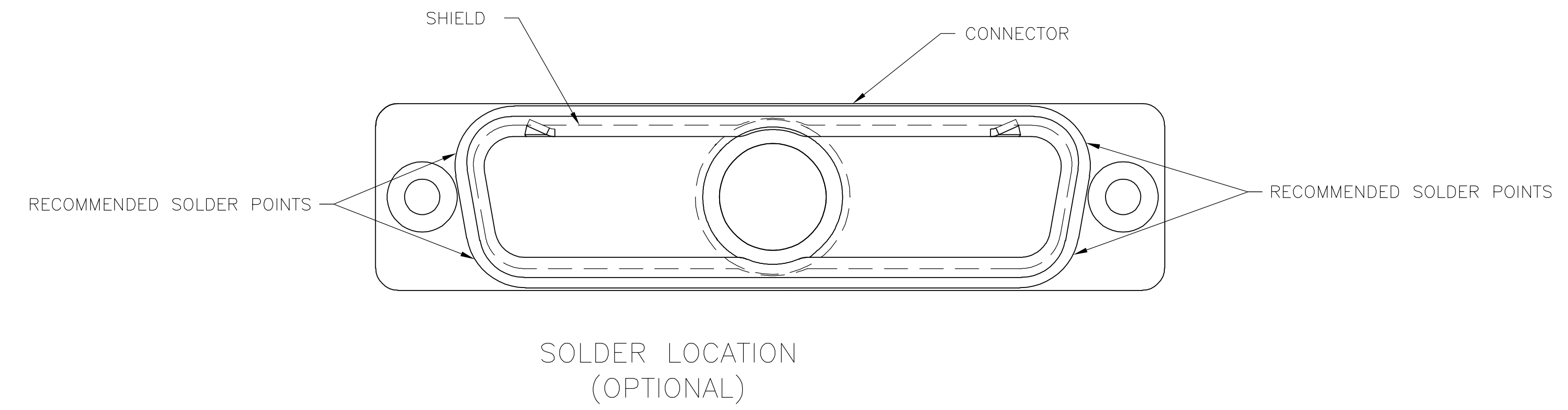
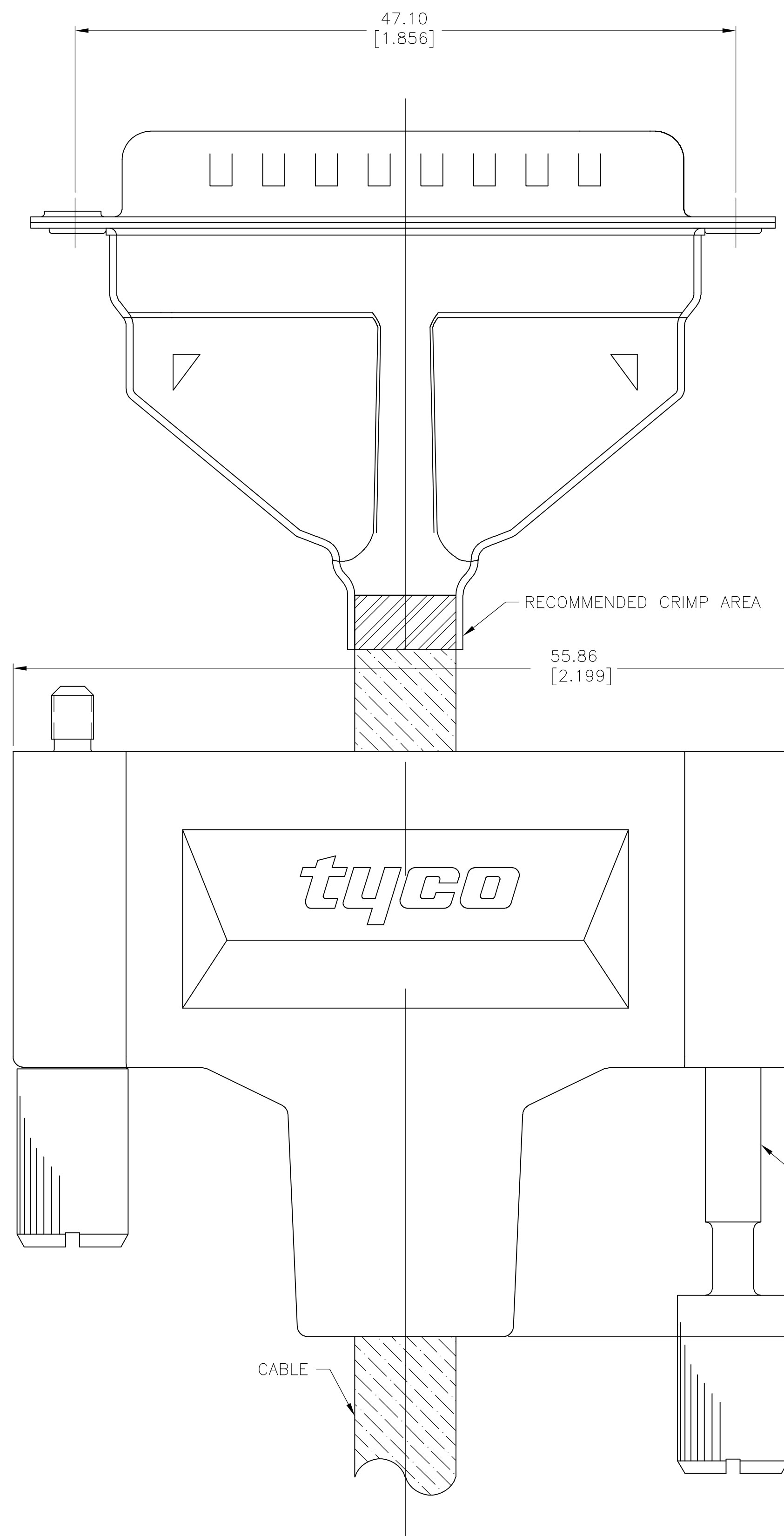

EXPLODED VIEW OF ASSEMBLED KIT

CABLE PREPARATION

ASSEMBLY INSTRUCTIONS

- USE SHIELD ENCLOSURE EXPANSION TOOL, 58241-1 TO GET ENCLOSURE ON CABLE.
- PREPARE CABLE AS SHOWN.
- PLACE CABLE THROUGH SHIELD.
- SOLDER CONDUCTORS TO CONTACTS.
- PRESS SHIELD ONTO CONNECTOR AS SHOWN.
- SOLDER SHIELD TO CONNECTOR AS SHOWN (OPTIONAL).
- CRIMP SHIELD TO CABLE AS SHOWN IN CRIMP DETAIL.
- PRESS ENCLOSURE OVER SHIELD UNTIL CONNECTOR FLANGE IS FLUSH WITH ENCLOSURE EDGE.
- INSERT JACKSCREWS.

THIS DRAWING IS A CONTROLLED DOCUMENT.		DWN	M. BINNER	21NOV03	tyco Electronics	Tyco Electronics Corporation Harrisburg, Pa 17105-3608	
DIMENSIONS: mm [INCHES]		CHK				NAME	BULK KIT, RECEPTACLE, AMPLIMITE SOLDER CUP SHIELDING ENCLOSURE 25 POSITION, SIZE 3
TOLERANCES UNLESS OTHERWISE SPECIFIED:		APPV			PRODUCT SPEC	108-40031	
0 PLC ± -					APPLICATION SPEC		
1 PLC ± 0.3[.012]					SIZE	A1	
2 PLC ± -					CAGE CODE	00779	
3 PLC ± -					DRAWING NO	1571656	
4 PLC ± -					RESTRICTED TO		
ANGLES ± -					WEIGHT		
FINISH					CUSTOMER DRAWING		
MATERIAL					SCALE	4:1	
					SHEET	2 OF 2	
					REV	D2	