

LAN9512 64QFN Customer Evaluation Board

PCB Revision B
Schematic Revision 1.0

Design Details

Board: Assembly No. 6577
Chip: 64 Pin QFN
Board Form Factor: 4" X 2.5"

Circuit Diagrams utilizing SMSC Products Are Included As A Means Of Illustrating Typical Semiconductor Applications: Consequently Complete Information Sufficient For Construction Purposes Is Not Necessarily Given. The Information Has Been Carefully Checked And Is Believed To Be Entirely Reliable. However, No Responsibility Is Assumed For Inaccuracies. Furthermore, Such Information Does Not Convey To The Purchaser Of The Semiconductor Devices Described Any License Under The Patent Rights Of SMSC Or Others. SMSC Reserves The Right To Make Changes At Any Time In Order To Improve Design And Supply The Best Product Possible.

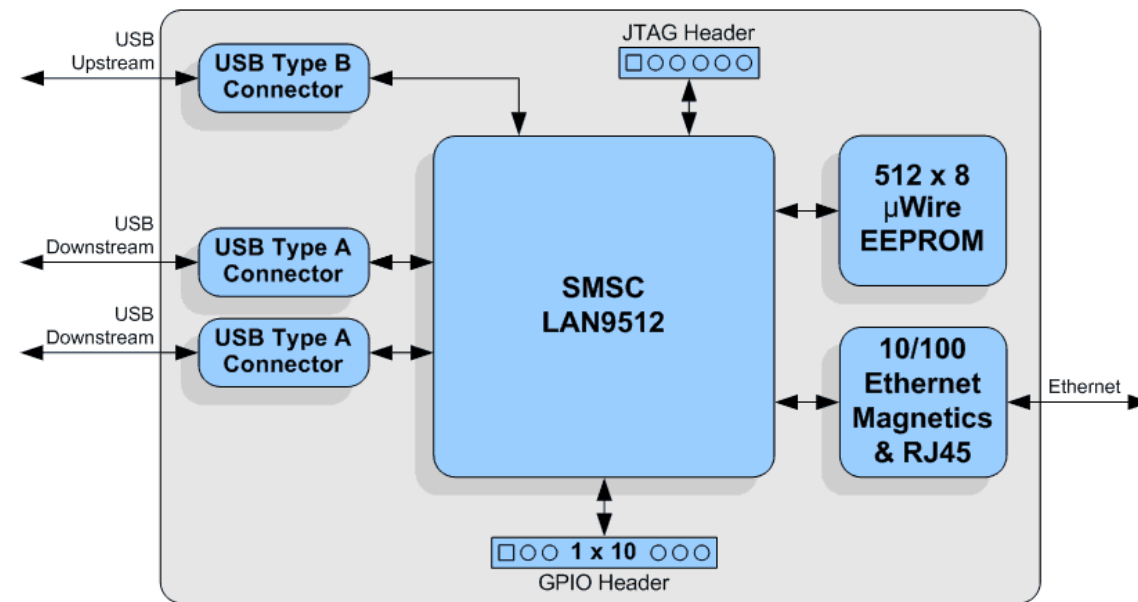

ITEM	Page
Title Page	1
EMI/ESD and Ethernet	2
LAN9512 and Power	3

Power Supply Filtering LAN9512

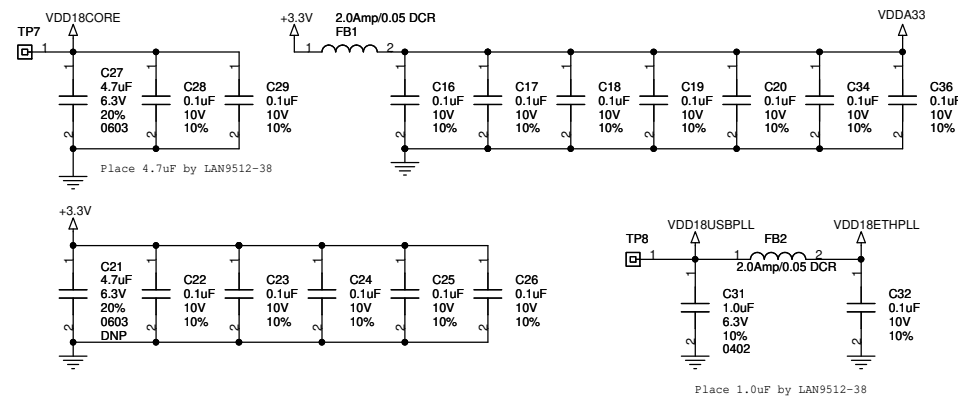

LAN9512

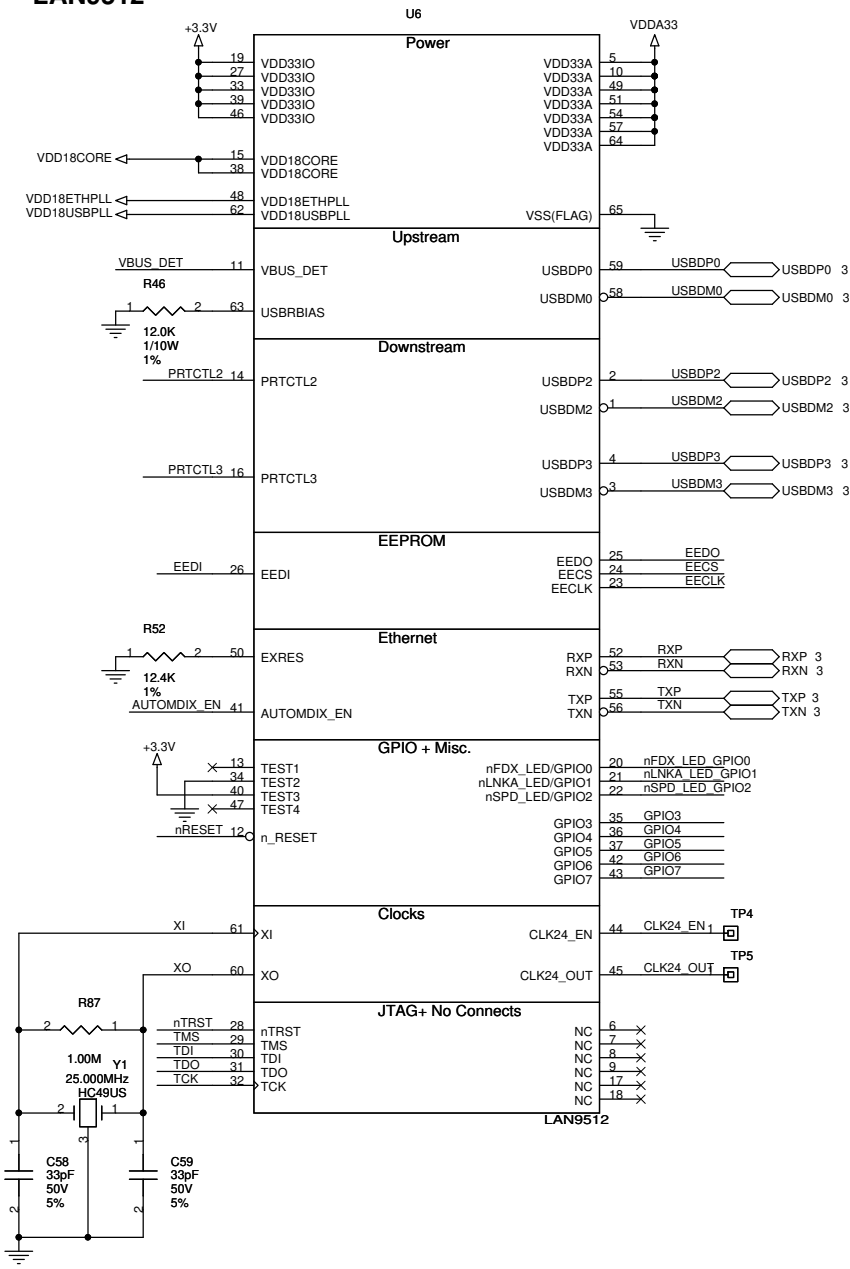

Upstream

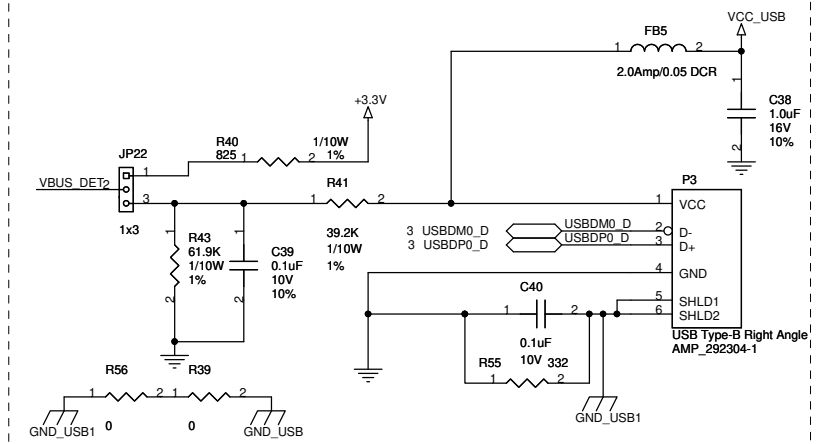

Miscellaneous Components

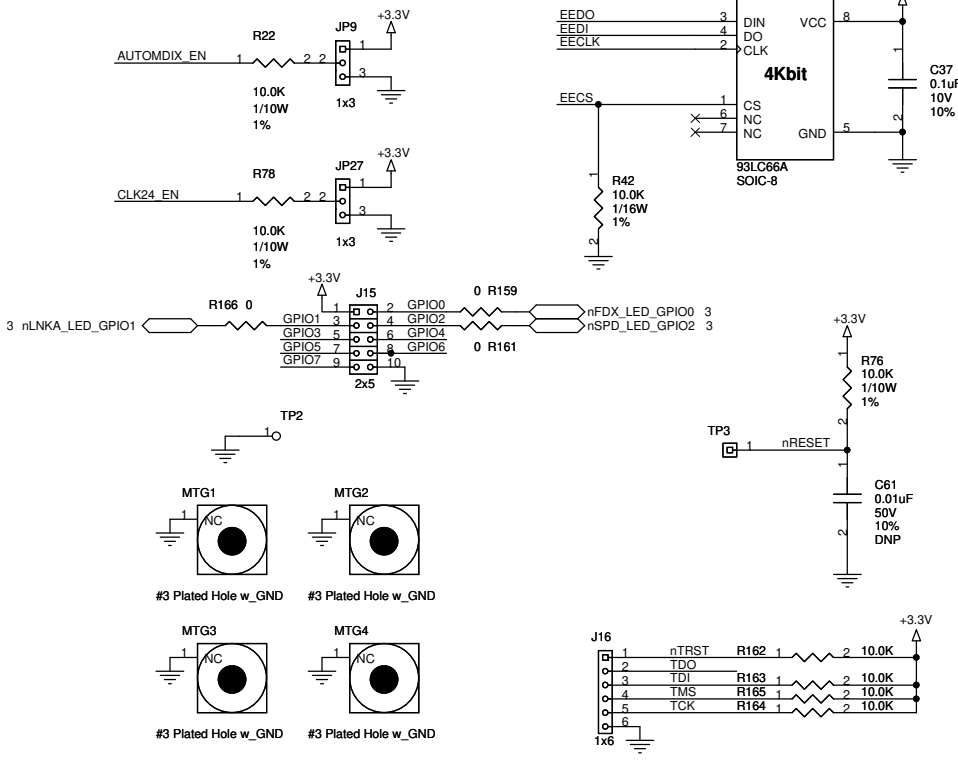

Downstream

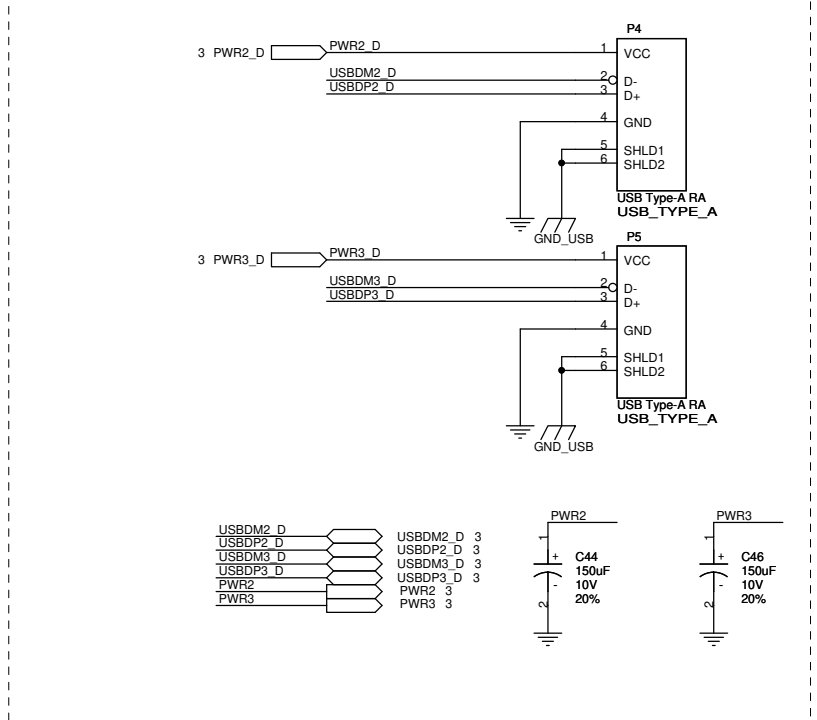

Input Power

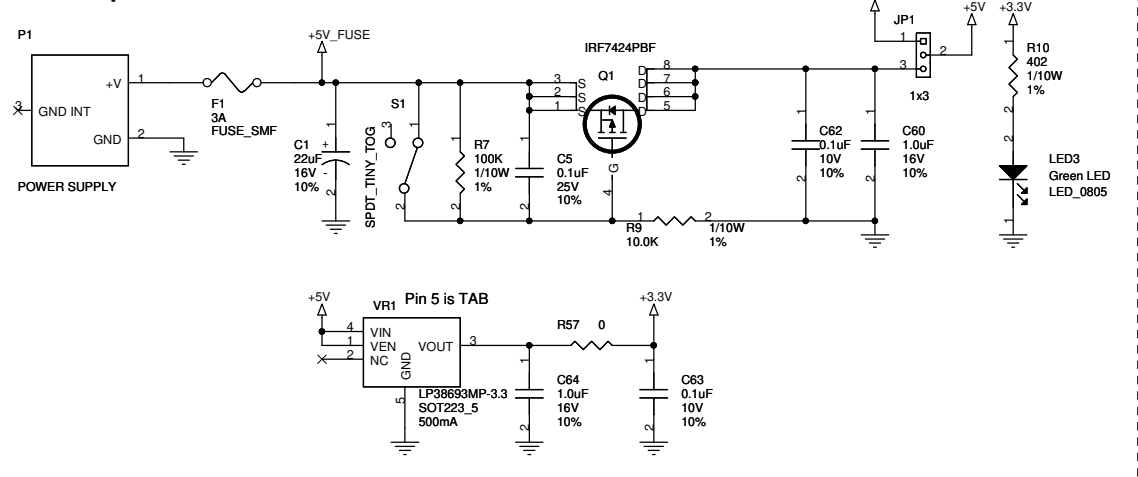

Power Switching Downstream

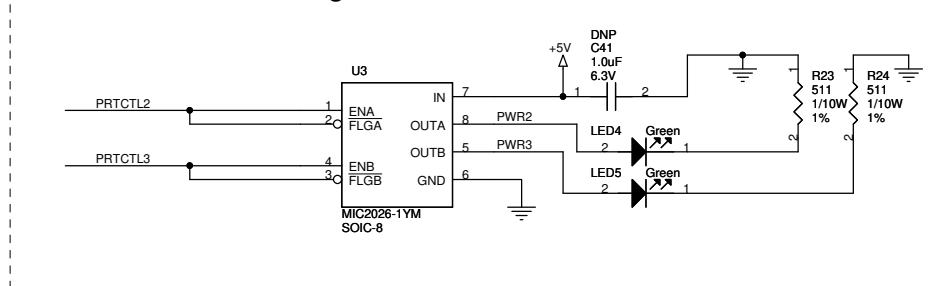

EMI and ESD

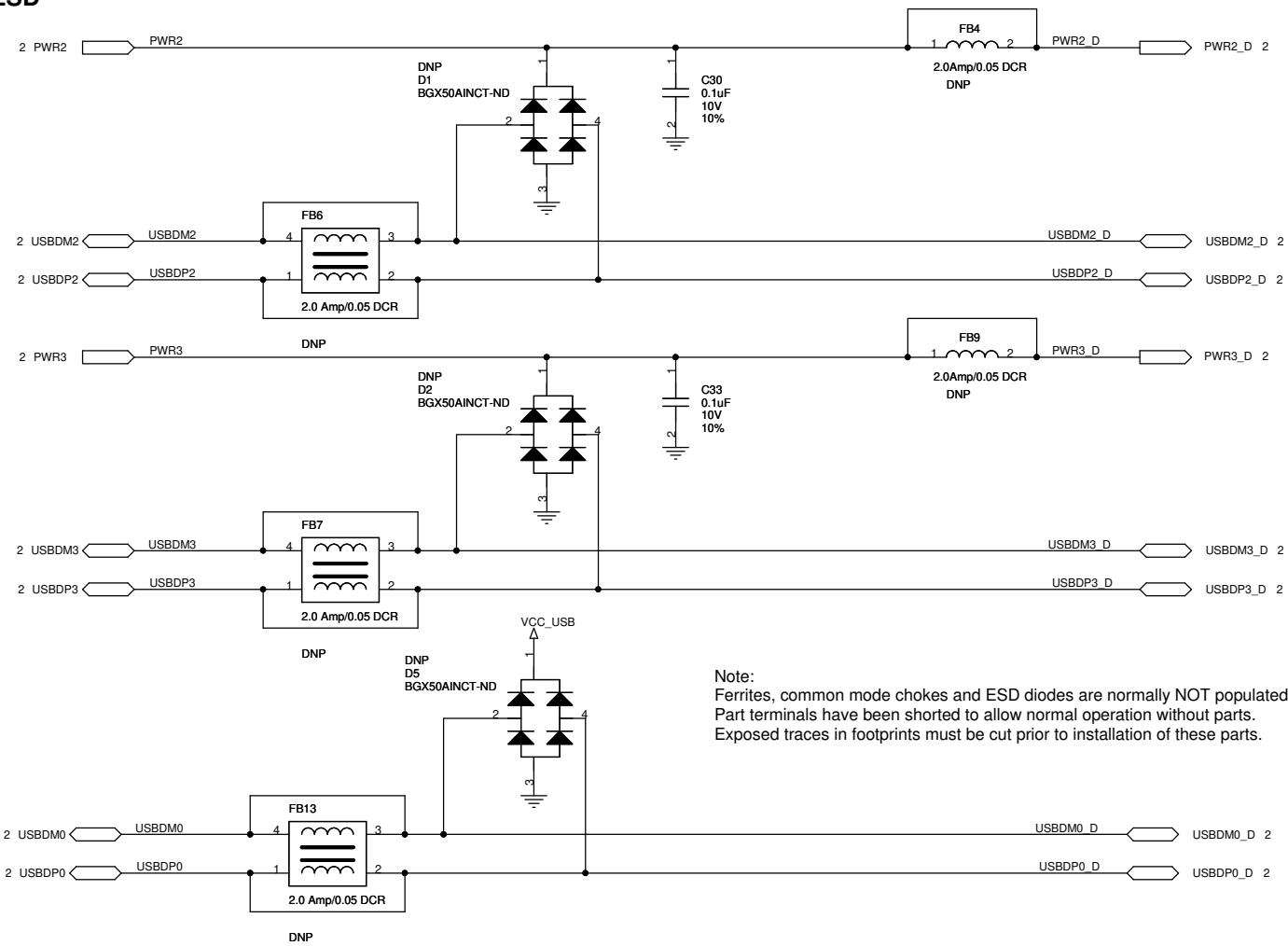

Ethernet

