

ScintiClear SC-6x6c-SiPM

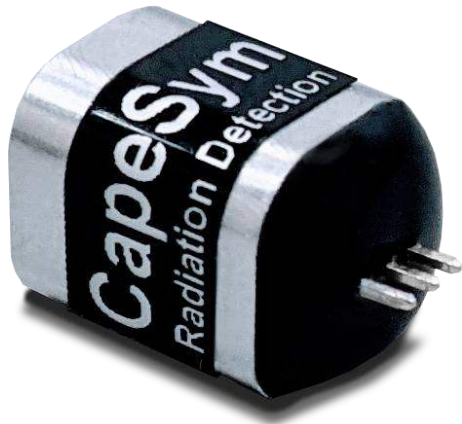

ScintiClear SC-6x6c-SiPM

Description

ScintiClear™ SC-6x6c-SiPM is a new high-performance $\text{SrI}_2(\text{Eu})$ -based solid state gamma radiation detector made in the USA. Our proprietary crystal growth and encapsulation processes improve the inherently excellent properties of $\text{SrI}_2(\text{Eu})$ scintillator and limit the negative effects of Eu self-absorption, with all the benefits of cutting edge SiPM technology. Typical energy resolution of ScintiClear detectors is 3.0% at 662 keV.

Specifications

Shape	Cuboid
Detector type	$\text{SrI}_2(\text{Eu})$
Detector size	6x6x6 mm
Energy range	From 10 keV
Typical resolution	3.0% at 662 keV
Typical sensitivity to gamma radiation, cps/ $(\mu\text{Sv}\cdot\text{h}^{-1})$	5 (^{137}Cs)
Readout	6mm SiPM
Dimensions	9x9x16 mm
Weight	3 g
Additional Features	Fast and standard outputs

Benefits

- Excellent energy resolution – 6% at 122 keV and 3% at 662 keV
- Ultra compact design
- Fully solid state detector not sensitive to magnetic field
- Low bias requirements: 26-32V
- High signal amplitude (can be used without preamp)
- Operating temperature: -40 to 55 °C

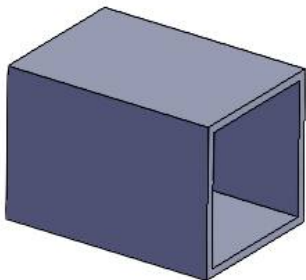

**Aluminum housing
(0.5 mm thk)**

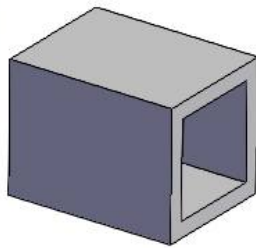

Reflector

**ScintiClear Crystal
6x6x6 mm**

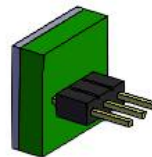
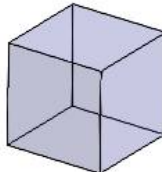

SiPM readout

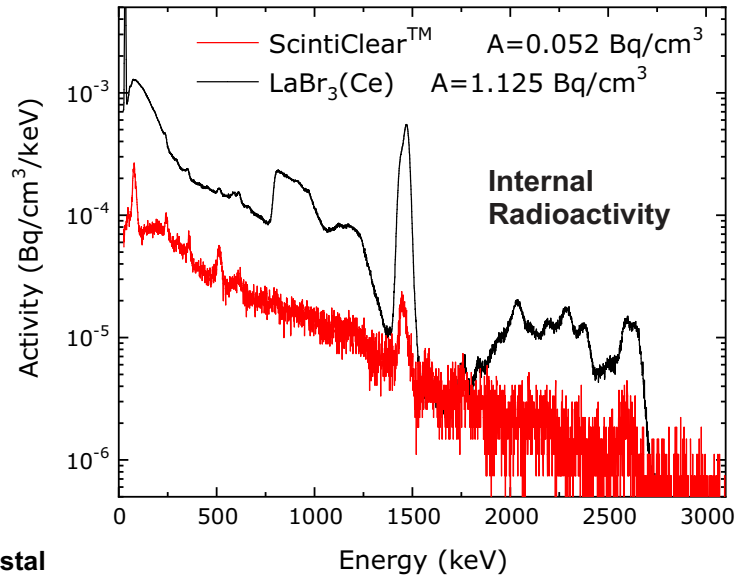

Because Strontium Iodide has a naturally stable isotopic composition, ScintiClear crystals enjoy the lowest intrinsic activity among high energy resolution scintillators available on the market. When compared to $\text{LaBr}_3(\text{Ce})$ intrinsic activity of ScintiClear is up to forty times smaller.

ScintiClear SC-6x6c-SiPM



Unambiguous Identification with ScintiClear*

* Presented spectra have been measured with SC-14x25c-SiPM-T and can be different for other detector configurations.

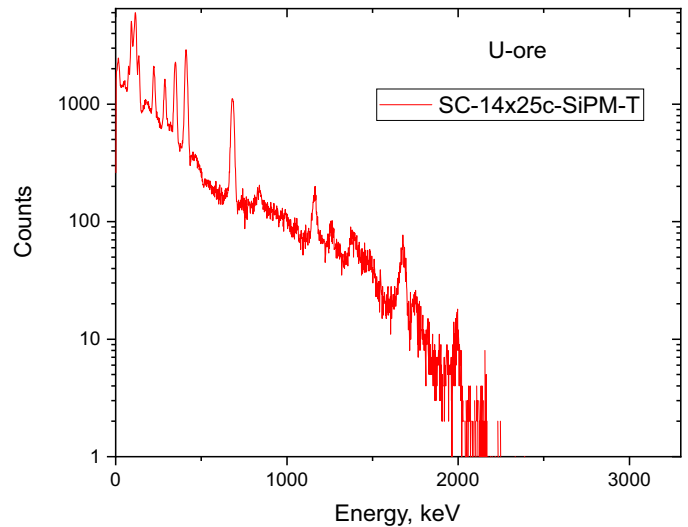
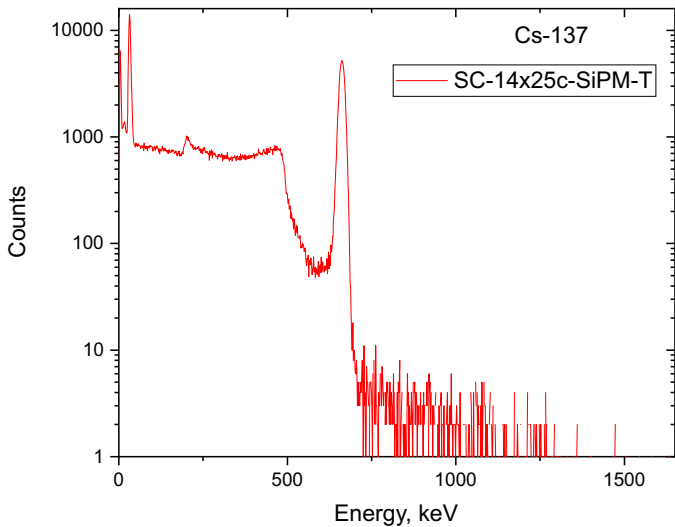
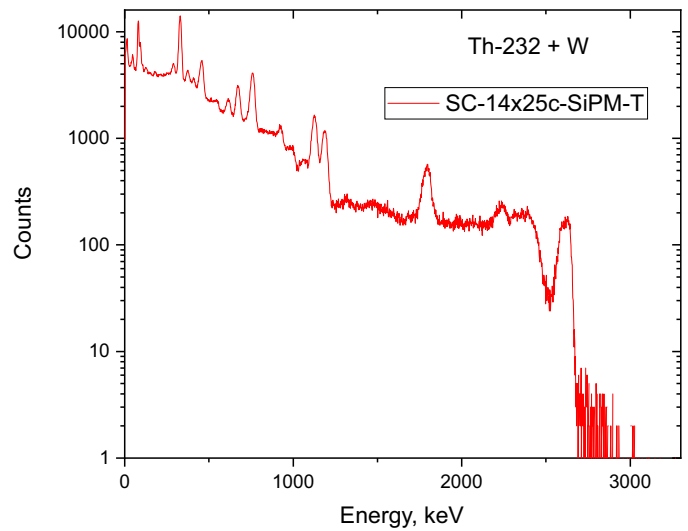
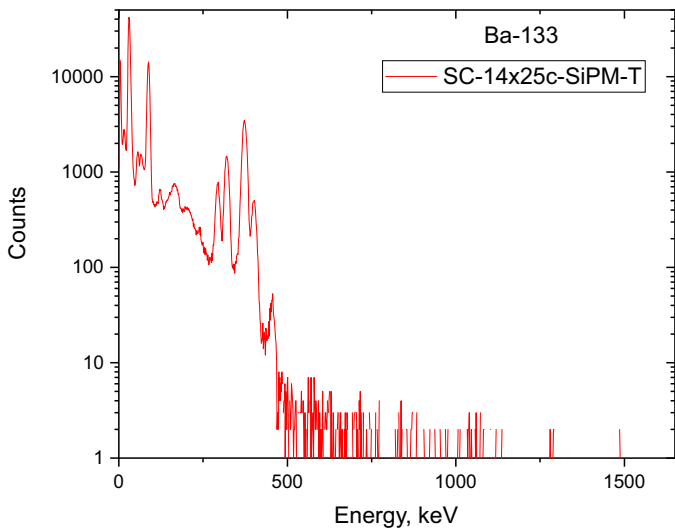
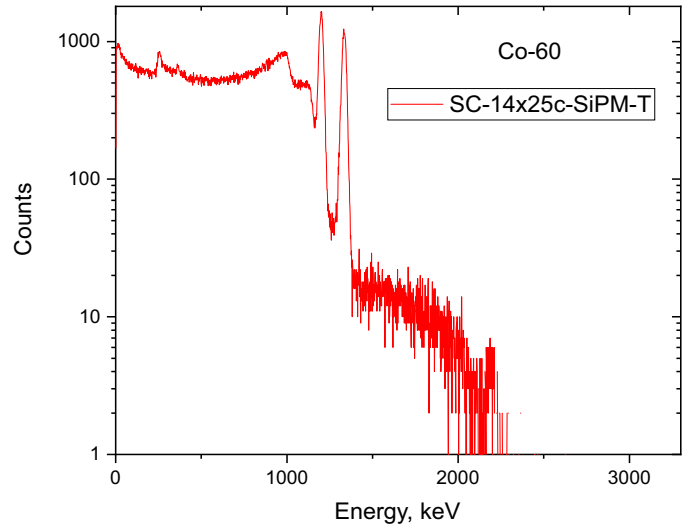
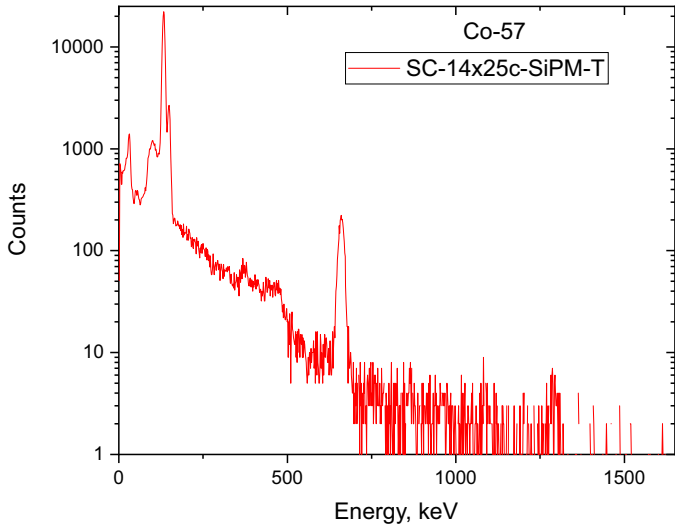

ScintiClear SC-6x6c-SiPM



2D drawing

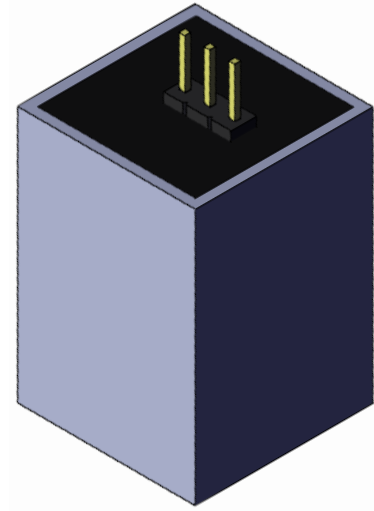
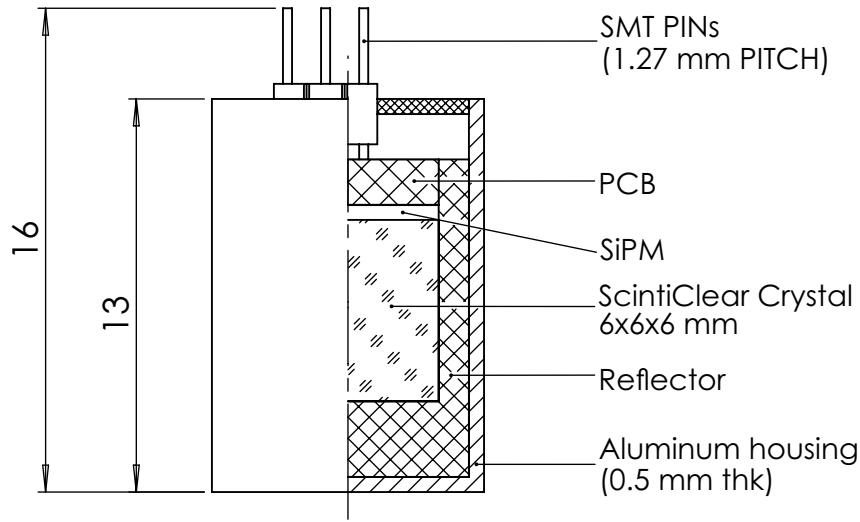

SCALE 4:1

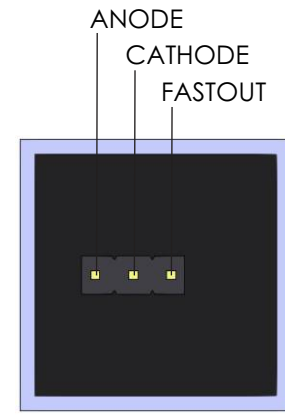
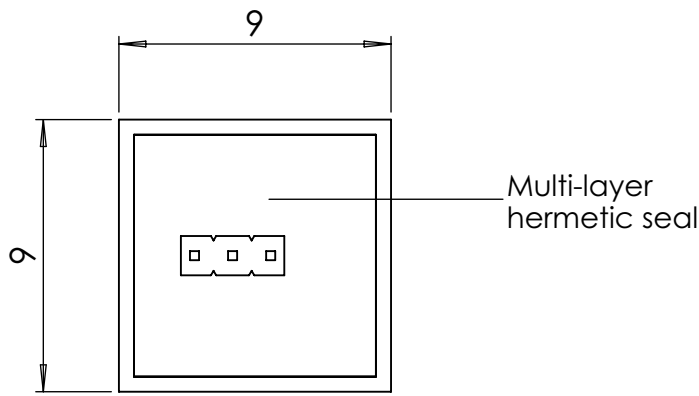

SCALE 4:1

Block Diagram

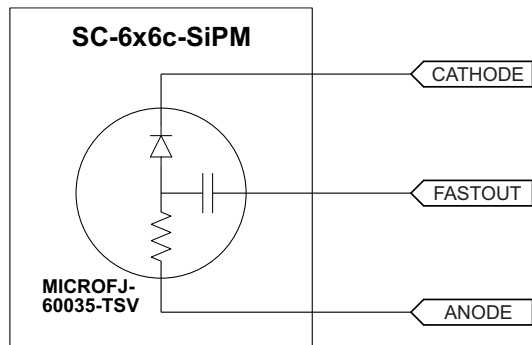

Typical Application

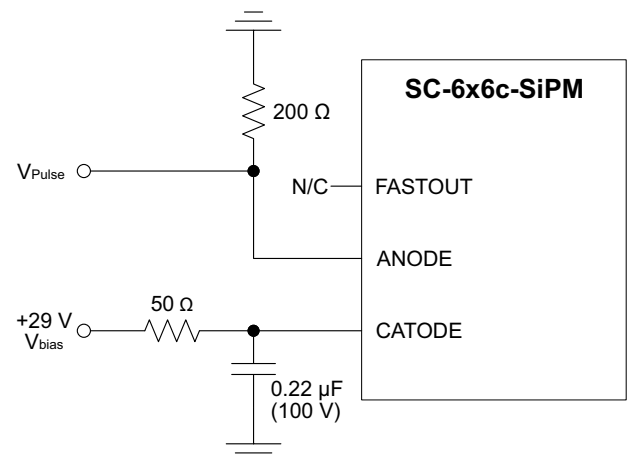



Biasing Alternatives & Signal Polarity

This Appendix lists all of the possible ways in which a J-Series SiPM can be biased. For each biasing arrangement, the standard and fast signal polarities are given. **A** and **B** are the recommended configurations. **C** and **D** will work, but are not recommended for use with the fast output. The following abbreviations are used throughout:

- V_{bias} = bias voltage
- S_{out} = standard output
- F_{out} = fast output
- R_s = load resistor for the standard output
- R_f = load resistor for the fast output
- V_s = standard output voltage
- V_f = fast output voltage
- R_Q = quench resistor (included on the SiPM die)
- C_1 = decoupling capacitor 10nF (50V), low ESR, ceramic

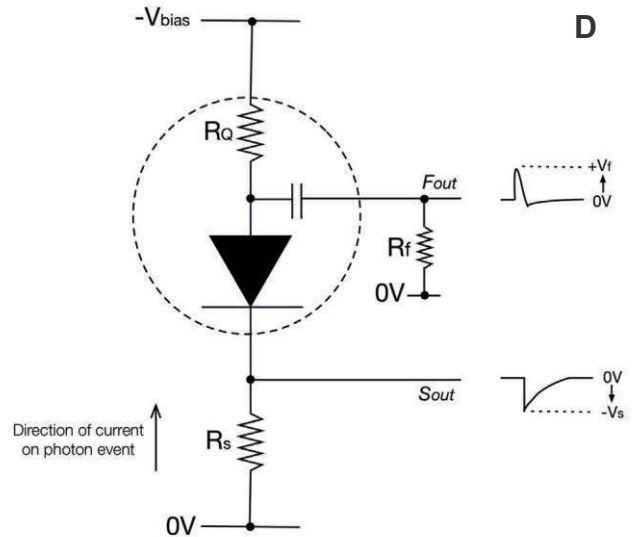
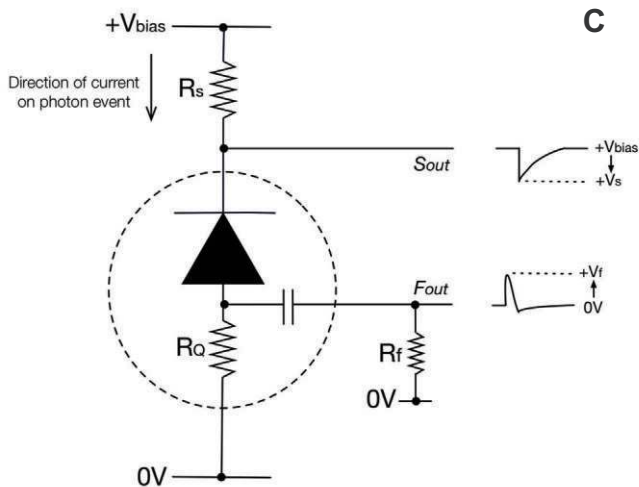
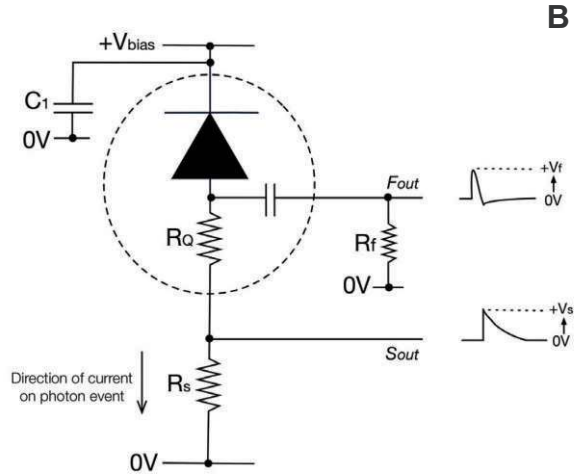
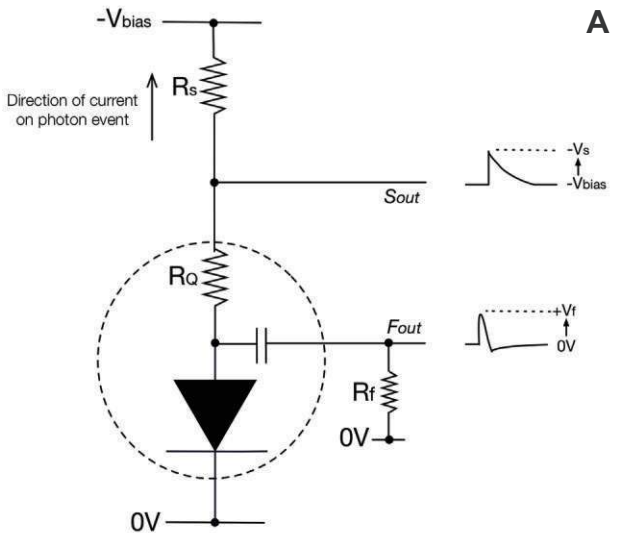
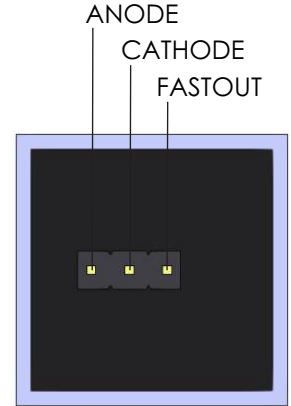

Ref.: J-Series High PDE and Timing Resolution, TSV Package, Datasheet, SensL

ScintiClear SC-6x6c-SiPM



Application note: How to use “traditional” analog electronics with MacroPixel

To start acquiring spectra with MacroPixel is easy and straight-forward. The following example is for SC-14x25c-SiPM-T ScintiClear detector, but a similar approach can be utilized for all MacroPixel detectors. All you need is the following “traditional” analog electronics available in many labs dealing with scintillators and radiation measurements:

1) Stable programmable current source, capable of providing ripple-free bias up to +30 V and limited to 0.5 mA or three 9 V batteries. Apply this bias to the cathode of the MacroPixel. Additional filter can be used to minimize the noise coming from the power supply and connection lines (Figure 1).

2) There is no need to use a preamplifier. Signal can be monitored directly from the anode of the MacroPixel connected to the ground through a 50 Ohms resistor (Figure 2). At +30 V bias a typical pulse corresponding to 3000 keV deposited energy is about 200mV in amplitude and 20 μ s long for SC-14x25c-SiPM-T.

3) Shaping spectroscopy amplifier. The most commonly available models are: Ortec 671, 672, and 673, and Canberra 2025 or 2026.

4) Multi-channel analyzer (MCA) with a software. In our example we used Ortec’s Easy MCA with Maestro (Figure 3) but any other MCA can be used.

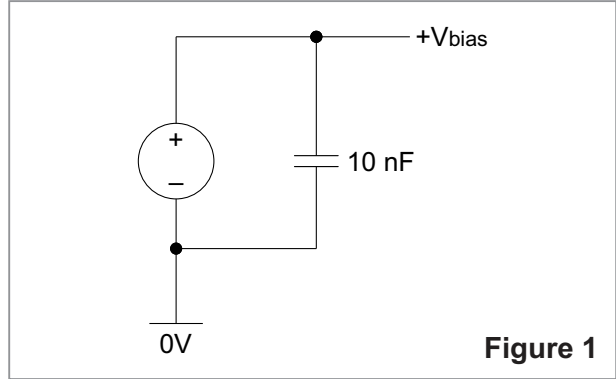

Figure 1

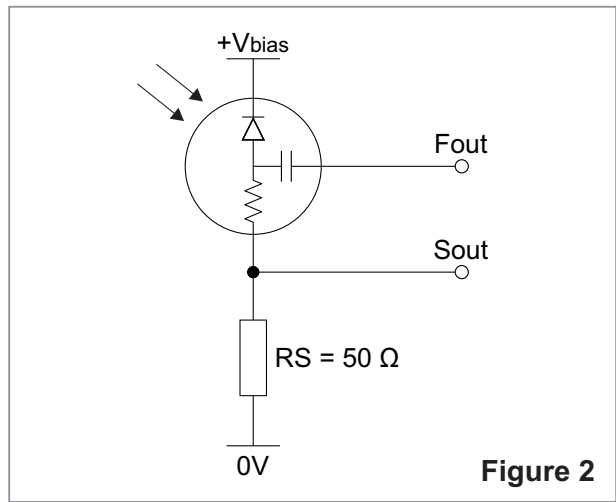

Figure 2

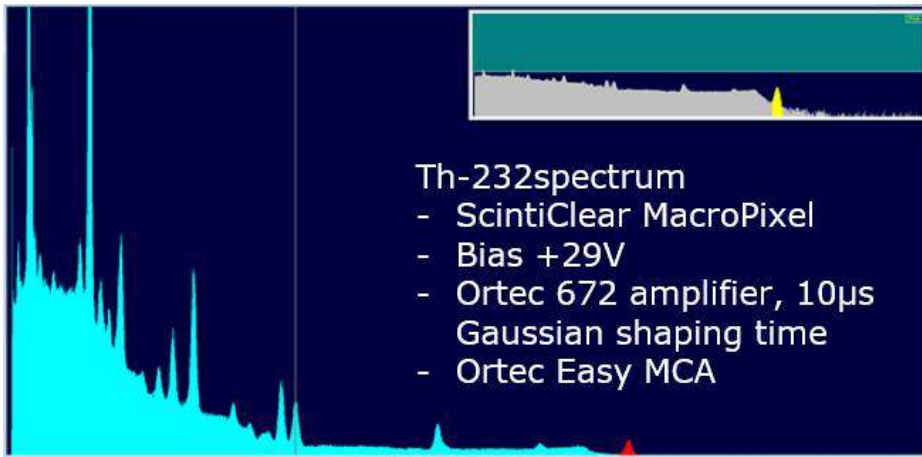

Figure 3

Th-232 emission spectrum measured with ScintiClear MacroPixel and “traditional” analog electronics. Bias +29 V, Ortec 672 amplifier, 10 μ s Gaussian shaping time, “+ NORM” input, 20 coarse gain



About CapeScint

CapeScint is a subsidiary of CapeSym, Inc. a multi-faceted company with 100+ years of combined experience in scintillators, semiconductors, and radiation detection instruments. CapeScint has its warehouse facilities and customer support staff located in Greater Boston Area, Massachusetts, USA.

Founded in 1992 as Cape Simulations, CapeSym, Inc. is now a multi-faceted company offering novel technical crystals and detectors for nuclear detection, including ScintiClearTM SrI₂(Eu) and ElpasolightTM CLYC(Ce) scintillators. In addition, CapeSym offers radiation detection instruments and equipment through www.zievert.com.



Our ongoing R&D leverages decades of experience in crystal growth, solid state physics, analytical chemistry, materials science, thermo-fluid transport, and engineering design. CapeScint as a subsidiary of CapeSym, Inc. has a long history working with the US Government as a contractor and as a supplier of essential goods and services. During the last 30 years CapeSym, Inc. and supported missions of multiple US Government agencies including NASA, MDA, USAF, DoE, DTRA, NIH, CWMD, and US Navy.



Design and specifications are subject to change without notice