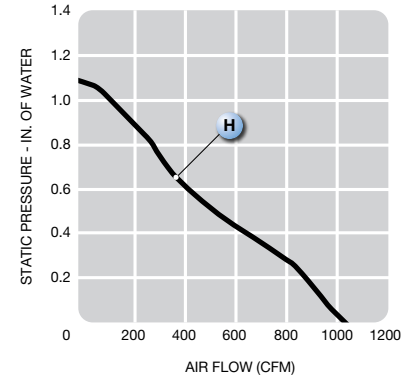
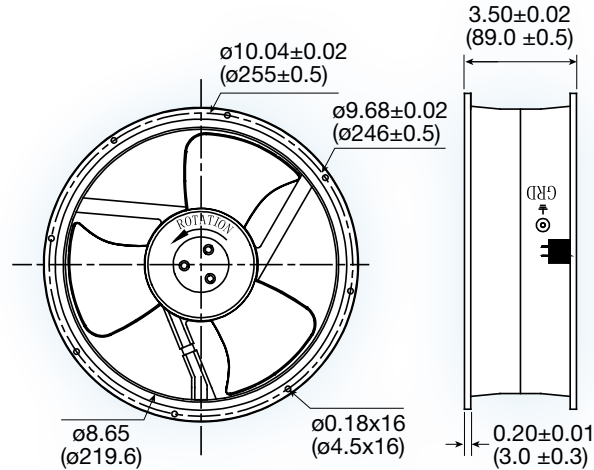

MM2589 series*

**(255 dia. x 89 mm)**

10.04 dia. x 3.50 inches

Construction: magnesium alloy impeller & frame

Bearing option: ball bearing

Connection: terminal or AWG 18 lead wire

Frame: flanged

Protection: thermal

Options: tachometer output or locked rotor alarm signal

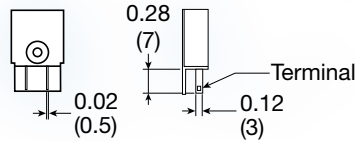

Model No.	Rated Voltage V	Current mA		Speed RPM	Air Volume		Max. Static Pressure (H ₂ O)		Sound Noise dB(A)	Weight kg
		24	48		M ³ /Min.	CFM	MM	INCH		
MM2589H	24/48	5200	2700	3,000	29	1030	27.94	1.1	60	1.60

*Not to be used for new designs