

THIS DRAWING IS UNPUBLISHED. RELEASED FOR PUBLICATION  
 © COPYRIGHT BY TYCO ELECTRONICS CORPORATION. ALL RIGHTS RESERVED.

LOC	DIST	REVISIONS					
G	14	P	LTR	DESCRIPTION	DATE	DWN	APVD
		F1		REV PER ECR 08-002293	25JAN08	JR	TM

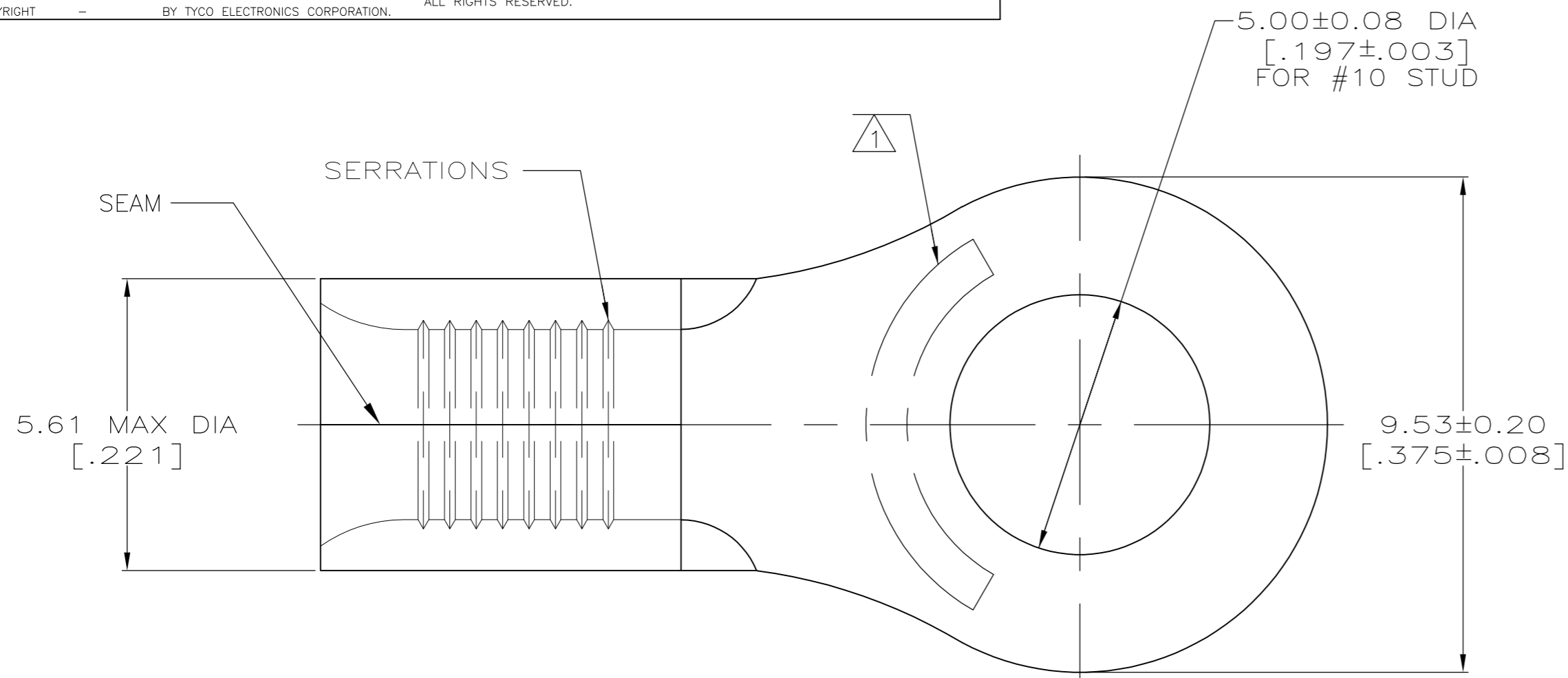

<b>AMP</b> WIRE RANGE	Listed FILE E13288
12-10 AWG STRANDED	12-10 AWG STRANDED

- 1 STAMP AMP 12-10\* APPROX AS SHOWN
- 2 SEAM FACING UPWARD ON TAPE
- 3 SEAM FACING DOWNWARD ON TAPE
- 4 COPPER PER ASTM B-152, ANNEALED
- 5 TIN PLATE 0.00254 [.000100] MIN THK PER ASTM B545

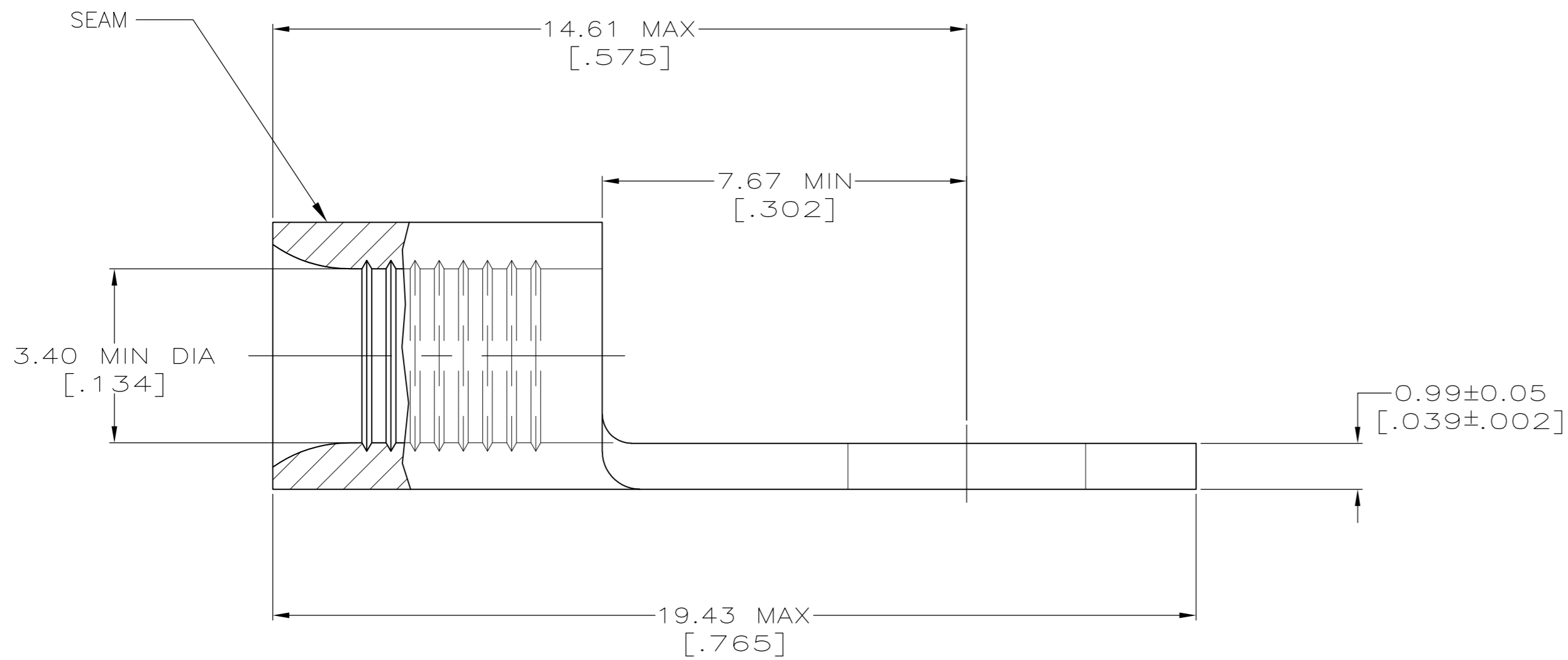

50	LOOSE PIECE, BOX	8-31114-2
2500	ON TAPE, REEL 3	31114-3
2500	ON TAPE, REEL 2	31114-2
-	LOOSE PIECE	31114
QTY	PACKAGE TYPE	PART NO.

<b>AMP INCORPORATED CUSTOMER SERVICE SYSTEMS</b>		MAX RECOMMENDED OPERATING TEMPERATURE: 170°C MAX	THIS DRAWING IS A CONTROLLED DOCUMENT.		DWN TA BRINKMAN 2-8-93	Tyco Electronics Corporation Harrisburg, PA 17105-3608
FOR ADDITIONAL PRODUCT INFORMATION OR COPIES OF DRAWINGS AND TECHNICAL DOCUMENTS	PRODUCT INFORMATION CENTER 1-800-522-6752	VOLTAGE RATING: N/A	DIMENSIONS: MM [ INCHES ]	TOLERANCES UNLESS OTHERWISE SPECIFIED:	CHK DA PATTERSON 2-8-93	
FOR APPLICATION	TOOLING ASSISTANCE CENTER 1-800-722-1111	CIRCULAR MIL AREA: 2.62-6.64mm² [5,180-13,100] STRANDED		0 PLC ± - 1 PLC ± - 2 PLC ± - 3 PLC ± - 4 PLC ± - ANGLES ± -	APVD JL MECKLEY 2-8-93	NAME TERMINAL, RING TONGUE, BUDGET
TOOLING INFORMATION	1-800-526-5142	THIS DRAWING IS A CONTROLLED DOCUMENT FOR AMP INCORPORATED. IT IS SUBJECT TO CHANGE AND THE CONTROLLING ENGINEERING ORGANIZATION SHOULD BE CONTACTED FOR THE LATEST REVISION.	MATERIAL - 4	FINISH - 5	PRODUCT SPEC -	SIZE A2
FOR ORDER ENTRY	1-800-526-5142				APPLICATION SPEC -	CAGE CODE 00779
					WEIGHT -	DRAWING NO C=31114
					CUSTOMER DRAWING	RESTRICTED TO -
					SCALE 10:1	SHEET 1 of 1
					REV F1	

31114

A