

PRODUCT NUMBER

10118884-XXX XXX XLF

- LEAD FREE (SEE NOTE 1,10)
- PACKAGING OPTIONS (SEE NOTE 1)
- INDICATE DIFFERENT MATING LENGTH AND TAIL LENGTH AND POLARIZED PIN AND OTHER INFORMATION
- NO OF POSITIONS (SEE NOTE 1)
- PIN PLATING (SEE SHEET 2)
- BASE PART NO.

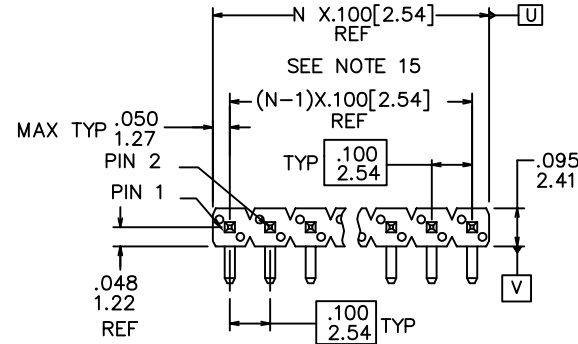

TOP VIEW

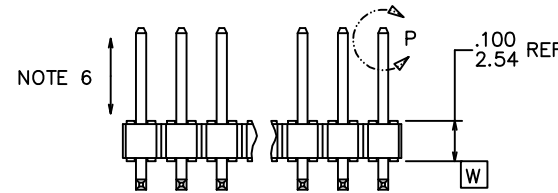

SIDE VIEW

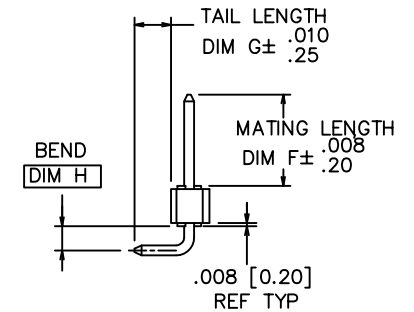

END VIEW

⊕ ∅.020/0.51 (M) U (M) V (S) W NOTE 4

□ .025±.001
0.64±0.03 TYP

□ .013
0.33 MAX TYP

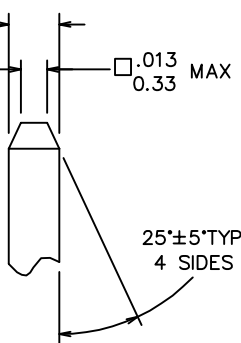

DETAIL P
TYP BOTH ENDS

mat'l. code		surface		tolerance		projection		product family	
NOTE 2 & 3		ISO 1302 ✓		ISO 406		INCH/MM		BERGSTIK	
ISO 1101		tolerances unless otherwise specified		.XX±.01/.XX±.3		scale 2:1		title	
ltr	ecn	nldr	date	angles	linear			BERGSTIK II HEADER D/R	
A	--	JZ	2011-10-21	0°±2'	.XXX±0.005/.XXX±.13			.100/2.54cc SR R/A	
B	ELX-N-13546	DCS	2012-11-28		.XXX±0.020/.XXX±.051			dwg no	
C	ELX-N-13546	ZK	2013-10-13					sheet 1 of 3	
D	ELX-N-16730	ZK	2014-01-15	dr	J ZHOU	2011-10-21		10118884	
E	ELX-N-17811	ZK	2014-05-30	engr	J ZHOU	2011-10-21		A3	
F	ELX-N-19815	JH	2014-12-22	chr	J ZHOU	2011-10-21		type	
G	ELX-N-23120	MZ	2016-01-25	appd	J ZHOU	2011-10-21		Product Customer Drawing	
sheet	revision	G	G	G					
index	sheet	1	2	3					

PIN PLATING CODES:

10118884-1YYXXLF	30u"/0.76u MIN (SEE NOTE 9) OVER 50u"/1.27u MIN Ni
10118884-2YYXXLF	15u"/0.38u MIN (SEE NOTE 9) OVER 50u"/1.27u MIN Ni
10118884-3YYXXLF	50u"/1.27u MIN (SEE NOTE 9) OVER 50u"/1.27u MIN Ni
10118884-4YYXXLF	100u"/2.54u MIN Sn OVER 50u"/1.27u MIN Ni (SEE NOTE 10)
10118884-5YYXXLF	30u"/0.76u MIN Au OVER 50u"/1.27u MIN Ni
10118884-6YYXXLF	15u"/0.38u MIN Au OVER 50u"/1.27u MIN Ni
10118884-7YYXXLF	15u"/0.38u MIN GXT OVER 50u"/1.27u MIN Ni
10118884-8YYXXLF	30u"/0.76u MIN GXT OVER 50u"/1.27u MIN Ni

NOTES

- PART NUMBER OPTIONS:
PIN PLATING CODES (SEE ABOVE)
HIGH TEMP. MATERIAL:
PART NUMBERS WILL BE SUPPLIED WITH HIGH TEMPERATURE PLASTIC.
NUMBER OF POSITION:
ANY NUMBER OF POSITIONS FROM 1 THRU 36.
PACKAGING:
PACKAGED IN POLY BAGS.
THE FIFTEENTH DIGIT PART NUMBERS FOLLOWED BY A "T" ARE PACKAGED IN TUBES.
THE FIFTEENTH DIGIT PART NUMBERS FOLLOWED BY A "A" ARE PACKAGED IN TAPE AND REEL WITH CAP (DETAIL AS FIGURE 1).
LEAD FREE:
ADD "LF" SUFFIX AT THE END OF PART NUMBER FOR LEAD FREE.
- BODY MATERIAL:
MANUFACTURER'S OPTION OF NYLON OR PCT, GLASS FIBER REINFORCED, OR LCP MINERAL FILED FLAME RETARDENT PER UL-94V-0.
COLOR: BLACK.
PART NUMBERS WILL WITHSTAND EXPOSURE TO 260°C PEAK TEMPERATURE FOR 20 SECONDS IN WAVE SOLDER, INFRA-RED OR VAPOR PHASE SOLDER PROCESS.
- PIN MATERIAL: PHOS-BRONZE.
- MEASURED WITH PART IN RESTRAINED CONDITION.
- TWO SIDES OF PIN TIPS NOT PLATED. TYPICAL BOTH ENDS.
- 2LBS/0.9KG MIN PIN RETENTION IN EITHER DIRECTION.
- MILITARY BERGSTIK HEADER
P/N XXXXX-YYY-MIL
NOT AVAILABLE.
- THESE PRODUCTS MEETS EUROPEAN UNION DIRECTIVES AND OTHER COUNTRY REGULATION AS DESCRIBED IN GS-22-008.

- PLATING OPTIONS:
MAY BE EITHER GOLD OR GXT PLATED AT MANUFACTURER'S OPTION.
- "THIS PRODUCT HAS 100% TIN PLATING IN THE INTERFACE AND HAS NOT BEEN TESTED FOR WHISKER GROWTH IN ALL INTERCONNECT ENVIRONMENTS."
- THE OAL DON'T EXCEED 31mm
- INCREMENTS BY 0.1mm IN LENGTHS ONLY
- FOR SPECIAL PACKAGING REQUEST PLEASE CONTACT PRODUCT MANAGER FOR AVAILABILITY
- BEND DIMENSIONS AT 1.5mm , CAN BE UPDATED PER CUSTOMER REQUEST.
- TO DETERMINE DIMENSIONS:
N=NUMBER OF POSITION PER ROW
EXAMPLE: 10 POS. N X .100/2.54

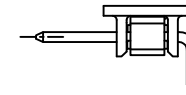

CAP ASSEMBLY SKETCH
FIGURE 1

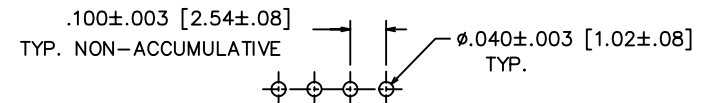

RECOMMENDED HOLE PATTERN

mat'l. code NOTE 2 & 3		surface ISO 1302 ✓	tolerance ISO 406 ISO 1101	projection 	product family BERGSTIK
ltr	ecn	no	dr	date	title
6					BERGSTIK II HEADER D/R .100/2.54cc SR R/A
		angles	linear	0°±2'	INCH/MM scale 2:1
					dr J ZHOU 2011-10-21
					enr J ZHOU 2011-10-21
					chr J ZHOU 2011-10-21
					app J ZHOU 2011-10-21
sheet	revision				 10118884 type Product Customer Drawing
index	sheet				

PRODUCT NUMBER	MATING LENGTH		TAIL LENGTH		BEND DIM		POLARIZED PIN	LF
	DIM F	DIM F	DIM G	DIM G	DIM H	DIM H		
	INCH	MM	INCH	MM	INCH	MM		
10118884-XYY001LF	0.230	5.84	0.295	7.49	0.060	1.52	-	NOTE 1,10
10118884-XYY002LF	0.244	6.20	0.120	3.05	0.060	1.52	2,3,4	NOTE 1,10
10118884-XYY003LF	0.138	3.50	0.238	6.05	0.060	1.52	2,3,4	NOTE 1,10
10118884-XYY004LF	0.230	5.84	0.120	3.05	0.060	1.52	-	NOTE 1,10
10118884-XYY005LF	0.157	4.00	0.238	6.05	0.060	1.52	-	NOTE 1,10
10118884-XYY006LF	0.300	7.62	0.120	3.05	0.060	1.52	-	NOTE 1,10
10118884-XYY007LF	0.230	5.84	0.090	2.29	0.060	1.52	-	NOTE 1,10
10118884-XYY008LF	0.230	5.84	0.390	9.91	0.060	1.52	-	NOTE 1,10
10118884-XYY009LF	0.318	8.08	0.120	3.05	0.060	1.52	-	NOTE 1,10
10118884-XYY010LF	0.230	5.84	0.590	14.99	0.060	1.52	-	NOTE 1,10
10118884-XYY011LF	0.157	4.00	0.238	6.05	0.060	1.52	2,3,4,5	NOTE 1,10
10118884-XYY012LF	0.157	4.00	0.238	6.05	0.060	1.52	2,3,	NOTE 1,10
10118884-XYY013LF	0.138	3.50	0.238	6.05	0.060	1.52	2,3,4,5	NOTE 1,10
10118884-XYY014LF	0.359	9.12	0.118	3.00	0.157	4.0	-	NOTE 1,10

Amphenol
FCi

© 2016 AFCI

mat'l. code NOTES 2 & 3				surface 58 ISO 1302 ✓		tolerance ISO 406 ISO 1101		projection 		product family BERGSTIK		
ltr	ecn	no	dr	date	tolerances unless otherwise specified					title		
D	ELX-N-16730	ZK		2014-01-15	angles	linear	.XX±01/.XX±.3	INCH/MM		BERGSTIK II HEADER D/R		
E	ELX-N-17811	ZK		2014-05-30			.XXX±0.005/.XXX±.13			.100/2.54cc SR R/A		
F	ELX-N-19815	JH		2014-12-22	0±2°		.XXX±0.002/.XXX±.05	scale 2:1				
G	ELX-N-23120	MZ		2016-01-25	dr	J ZHOU	2011-10-21	Amphenol FCi		dwg no		sheet 3 of 3
					eng	J ZHOU	2011-10-21			10118884		A3
					chr	J ZHOU	2011-10-21			type		Product Customer Drawing
					appd	J ZHOU	2011-10-21					
sheet index	revision sheet	G	G	G	G	G	G					
		1	2	3								