

2x Ø1.70
REQUIRED HOLES FOR
TAPPING SCREWS
(SEE TABLE 3)

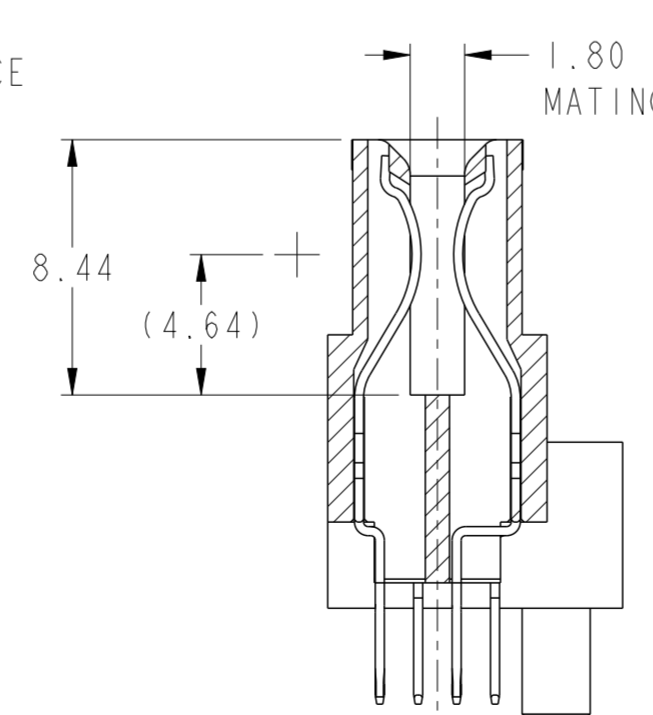
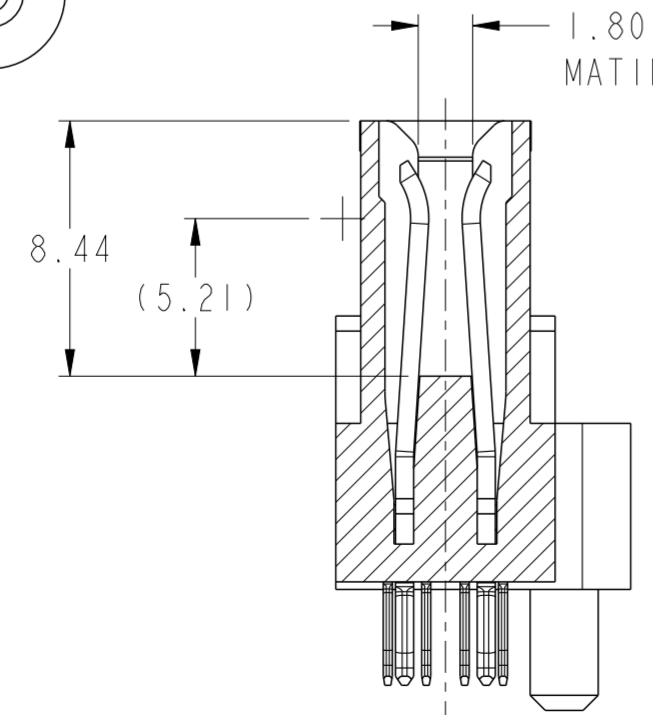
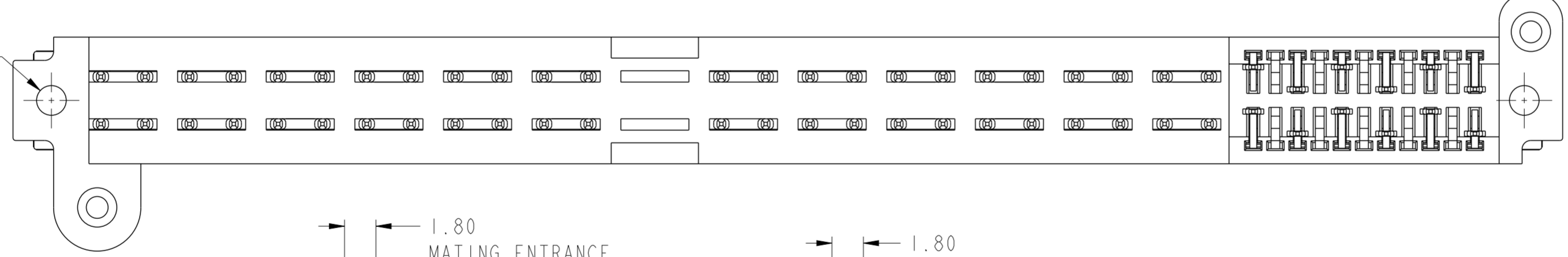

SECTION C-C

SECTION D-D

rev	ecn no	dr	date
A	-	JW	2012-09-13
-	-	-	-
-	-	-	-
-	-	-	-
-	-	-	-
-	-	-	-

spec ref	-	dr	Wei-Long Zhang	2012/09/15	projection	MM	size	A2	scale	4:1	
tolerance std	ASME Y14.5	eng	Julia Wang	2013/03/07			ecn no	-	rel level	Released	
surface	✓	chr	Eleven Hu	2013/03/07							
ASME Y14.5	linear	0.X	±0.5	0.XX	±0.25	0.XXX	±0.10	angular	0°	±2°	
TOLERANCES UNLESS OTHERWISE SPECIFIED		FCI		VERT RECT ASM (52P-22S)		HIGH POWER CARD EDGE		10121959		rev	A
www.fci.com		cat. no.		Product - Customer Drw		sheet 1 of 4					

PDS: Rev :A

STATUS:Released

Printed: Mar 08, 2013

Copyright FCI.

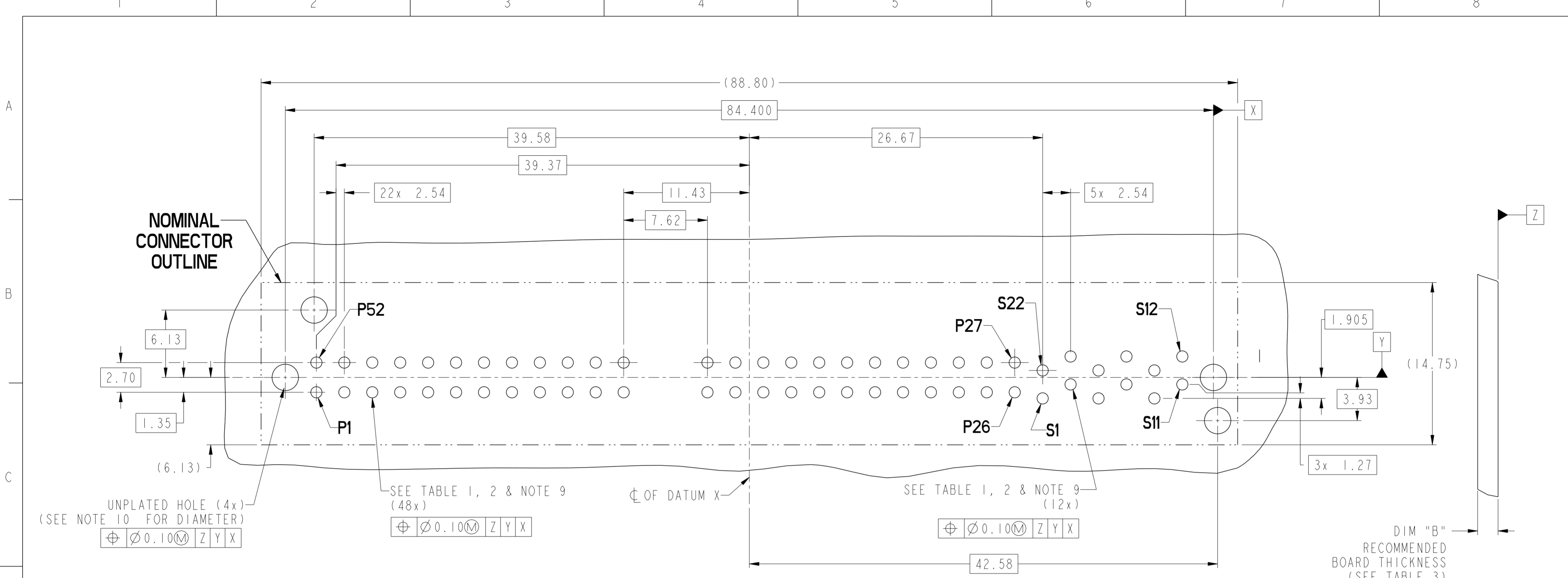

**RECOMMENDED PCB LAYOUT
VIEWED FROM CONNECTOR SIDE**

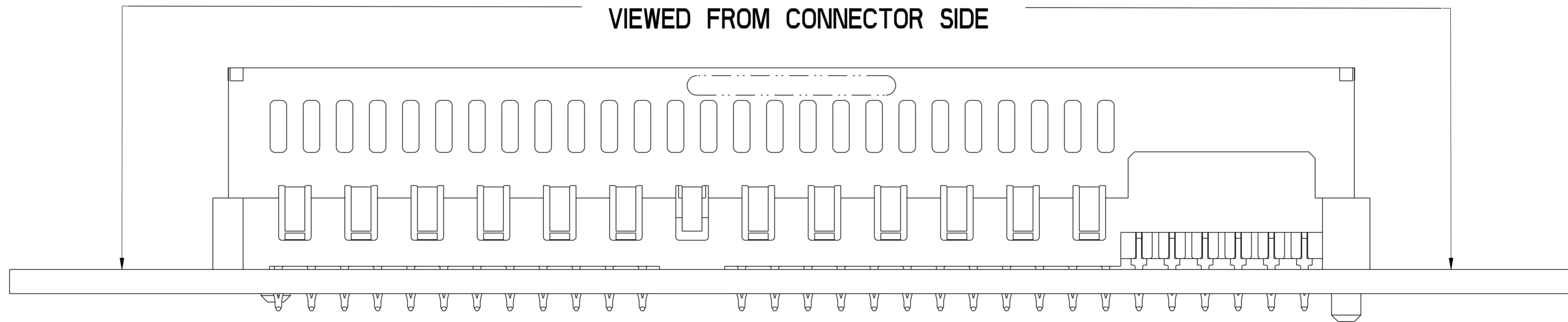

Copyright FCI.
FCI

dr	Wei-Long Zhang	2012/09/15	projection	MM	size	A2	scale	4:1			
eng	Julia Wang	2013/03/07			ecn no	-	rel level	Released			
chr	Eleven Hu	2013/03/07			product family	CARD EDGE					
appr	Pai-Ming Zheng	2013/03/07			title	VERT RECT ASM (52P-22S) HIGH POWER CARD EDGE		dwg no	10121959	rev	A
www.fci.com			cat. no.		-		Product - Customer Drw		sheet 2 of 4		

PDS: Rev :A

STATUS:Released

Printed: Mar 08, 2013

CONTACT TYPE	TOP LAYER DESCRIPTION	TABLE 1 (HPCE / SOLDER TAILS) PLATED THROUGH-HOLE REQUIREMENTS				
		DRILLED HOLE DIAMETER	COPPER THICKNESS	TIN-LEAD THICKNESS	TIN THICKNESS	FINISHED HOLE DIAMETER
POWER & SIGNAL	TIN-LEAD	1.10-1.16 (1.15 DRILL)	0.025 - 0.050	0.005 - 0.015	--	0.94 - 1.10
	IMMERSION TIN	1.10-1.16 (1.15 DRILL)	0.025 - 0.050	--	0.9 - 1.5um	0.94 - 1.10
	COPPER (SEE NOTE 8)	1.10-1.16 (1.15 DRILL)	0.025 - 0.050	--	--	0.94 - 1.10

CONTACT TYPE	TOP LAYER DESCRIPTION	TABLE 2 (HPCE / PRESS-FIT TAILS) PLATED THROUGH-HOLE REQUIREMENTS				
		DRILLED HOLE DIAMETER	COPPER THICKNESS	TIN-LEAD THICKNESS	TIN THICKNESS	FINISHED HOLE DIAMETER
POWER & SIGNAL	TIN-LEAD	0.81-0.86 (0.85 DRILL)	0.025 - 0.050	0.005 - 0.015	--	0.65 - 0.80
	IMMERSION TIN	0.81-0.86 (0.85 DRILL)	0.025 - 0.050	--	0.9 - 1.5um	0.70 - 0.80
	COPPER (SEE NOTE 8)	0.81-0.86 (0.85 DRILL)	0.025 - 0.050	--	--	0.70 - 0.80

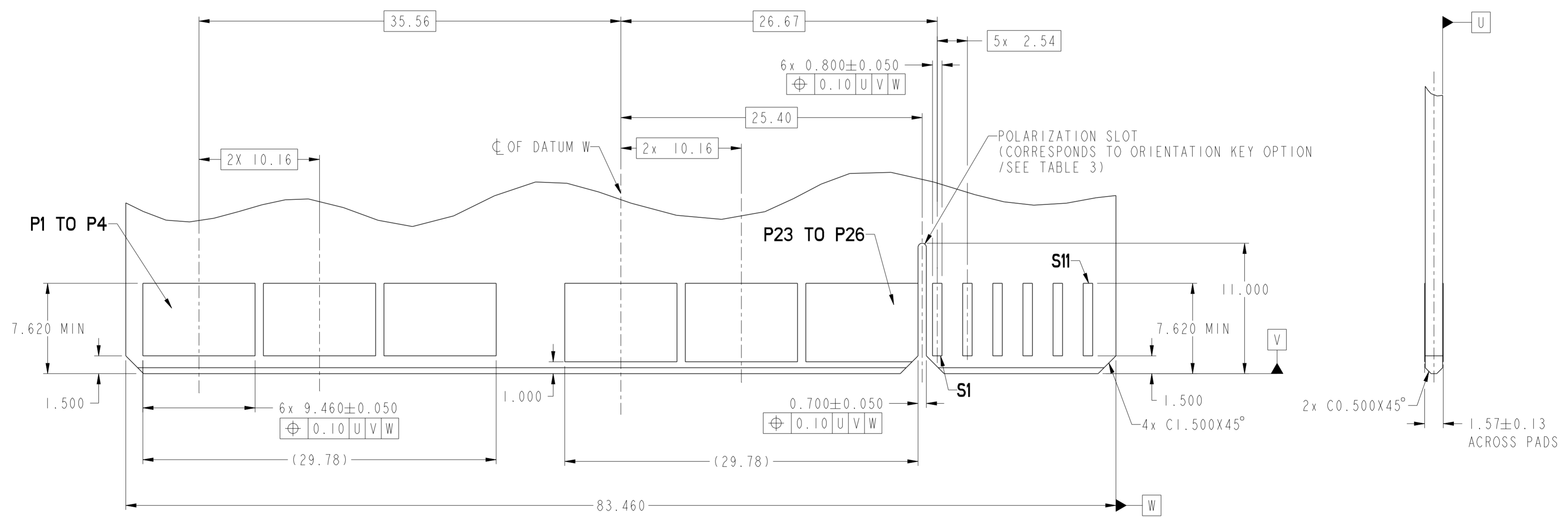

dr	Wei-Long Zhang	2012/09/15	projection	MM	size	A2	scale	4:1
eng	Julia Wang	2013/03/07			ecn no	-	rel level	Released
chr	Eleven Hu	2013/03/07						
appr	Pai-Ming Zheng	2013/03/07	product family	CARD EDGE	cat. no.	-	Product - Customer Drw	sheet 3 of 4
		VERT RECT ASM (52P-22S) HIGH POWER CARD EDGE			dwg no 10121959	rev A		

Copyright FCI. FCI

HPCE PART NUMBER (TABLE 3)

PART NUMBER	TAIL TYPE	ORIENTATION KEY	DIM "A" TYPICAL TAIL LENGTH	DIM "B" RECOMMENDED BOARD THICKNESS	REQUIRED FOR TAPPING SCREWS OPTION (RECOMMENDED)
10121959-001LF	PRESS-FIT	YES	3.17 ±0.25	1.59 - 2.38	M2
10121959-002LF		NO			

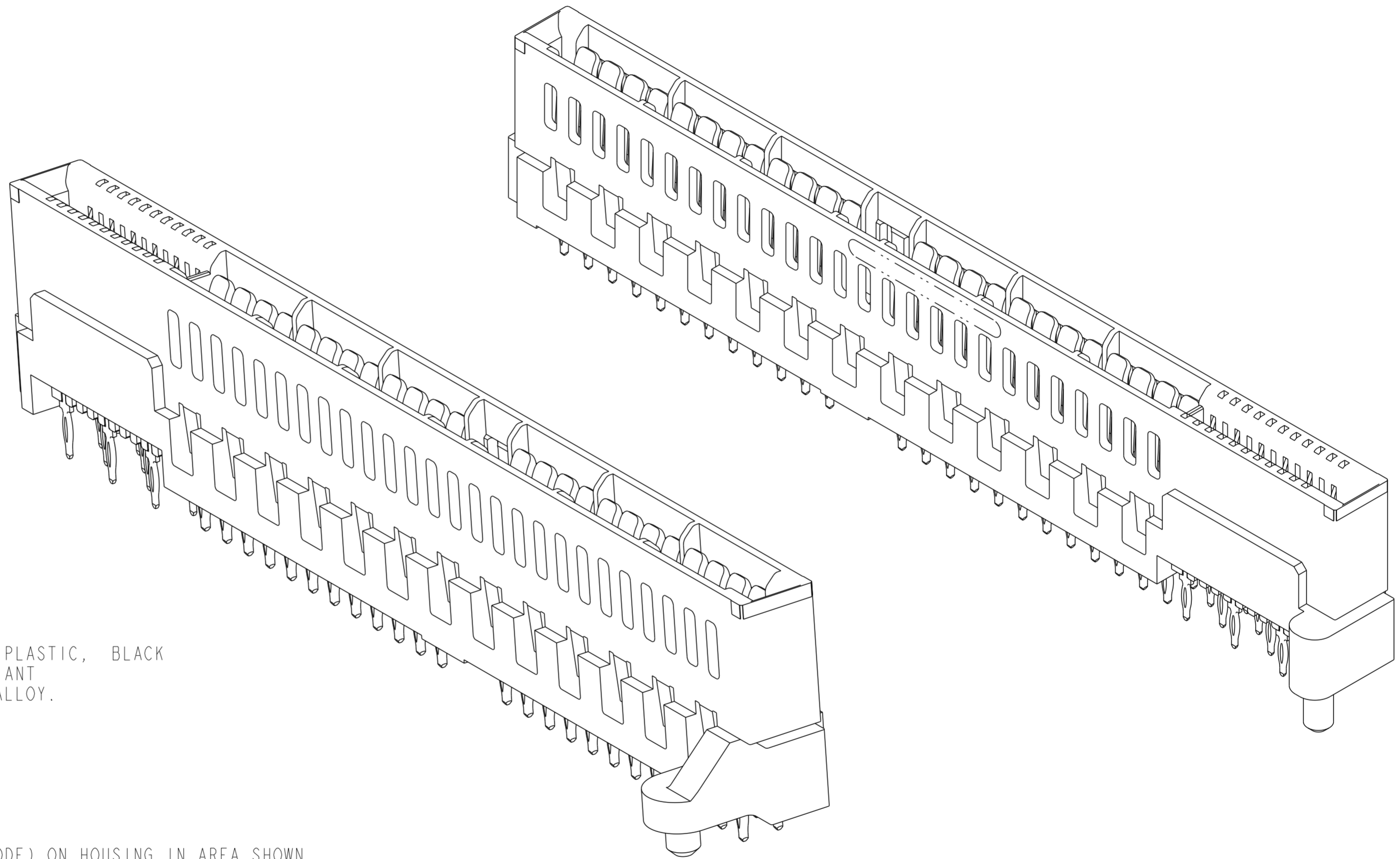

NOTES:

1. CONNECTOR MATERIALS:
 HOUSING: HIGH TEMPERATURE THERMAL PLASTIC, BLACK
 UL 94V-0 COMPLIANT
 CONTACTS: HIGH PERFORMANCE COPPER ALLOY.
2. CONTACT FINISH REF. GS-12-604 SECTION 5.2.
3. PRODUCT SPECIFICATION: GS-12-604.
4. APPLICATION SPECIFICATION: GS-20-128.
5. PRODUCT MARKING (FCI - PART NUMBER & DATE CODE) ON HOUSING IN AREA SHOWN.
6. PACKAGING MEETS FCI SPECIFICATION GS-14-937.
7. HOUSING COMPONENT WILL WITHSTAND EXPOSURE TO 260°C PEAK TEMPERATURE FOR 60 SECONDS IN A CONVECTION, INFRA-RED, OR VAPOR PHASE REFLOW OVEN.
8. COPPER PLATING THICKNESS IN CENTER OF VIA-HOLE CAN BE NO MORE THAN 0.003 LESS THAN OTHER AREAS.
9. ALL HOLE SIZES ARE FINISHED HOLE SIZES.
10. MOUNTING HOLES ARE UNPLATED
 $\varnothing 2.40 \pm 0.10$ FOR PRESS-FIT

dr	Wei-Long Zhang	2012/09/15	projection	MM	size	A2	scale	4:1
eng	Julia Wang	2013/03/07			ecn no.	-	rel level	Released
chr	Eleven Hu	2013/03/07			product family	CARD EDGE		
appr	Pei-Ming Zheng	2013/03/07			title	VERT RECT ASM (52P-22S)		rev
www.fci.com			cat. no.	-	Product - Customer Drw	sheet 4 of 4	rev	A