

## IGBT BASED DC SOLID-STATE RELAY



- ▶ Latest high voltage IGBT technology generation.
- ▶ New innovative isolated driver ensuring fast power transistor turn on and off therefore low power transient.
- ▶ Ultra low output leakage current
- ▶ Low control current consumption
- ▶ Triggered control input to avoid linear control risks
- ▶ Low conducted and radiated disturbances

# SCI0100600



Control voltage range	4.5-32VDC
Max transient peak voltage	600v
Advised max. DC Mains peak voltage	(Depends on protection clamping voltage)
Max. Load Current (with heatsink)	100ADC

DC Mains voltage range	Load current range	Control input voltage range	In & case / Out Insulation	Connections	Dimensions (WxHxD)	Weight
(Depends on protection clamping voltage)	0 to 100A (with heatsink)	4.5-32VDC	4kV	M3 round tabs M5 round tabs	44.5 x 58.2 x 27 (mm)	100g

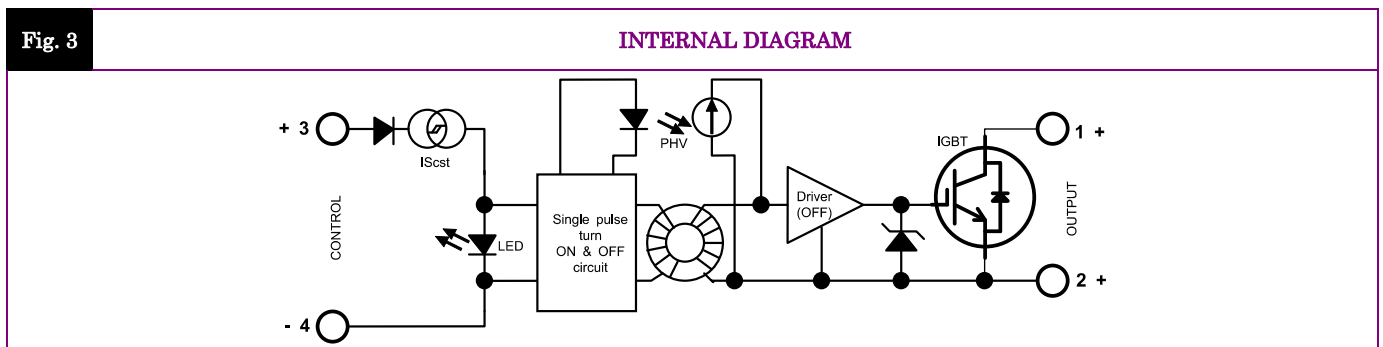
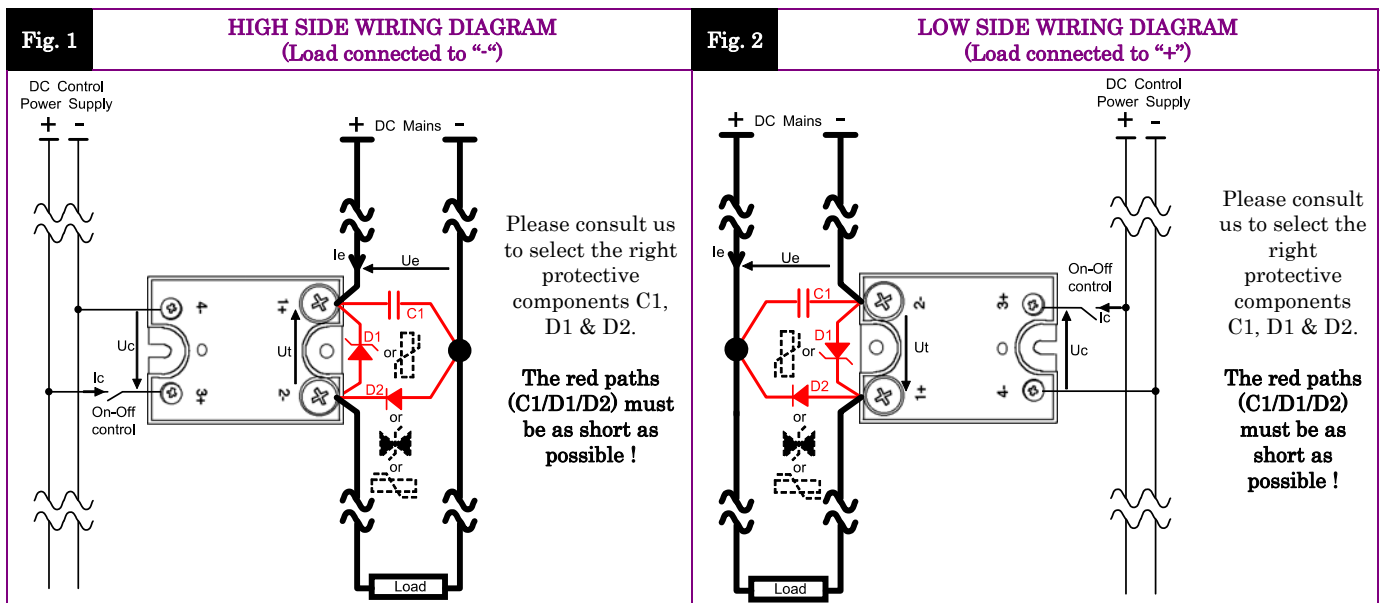

*Proud to serve you*

**CONTROL INPUT CHARACTERISTICS**

INPUT CIRCUIT	CHARACTERISTIC	LABEL	VALUE	INFO.	Fig. 4 CONTROL CURRENT vs. CONTROL VOLTAGE
	Nom. Control voltage	<b>U<sub>Cnom</sub></b>	12-24VDC		
	Nom. Control current	<b>I<sub>Cnom</sub></b>	35mADC		
	Control voltage range	<b>U<sub>c</sub></b>	4.5 – 32VDC	typical=4.3V	
	Control current consumption	<b>I<sub>c</sub></b>	25 – 42mADC	See curve	
	Releasing control voltage	<b>U<sub>Coffmax</sub></b>	1VDC	Typical= 3.5V	
	Max. reverse control voltage	<b>-U<sub>Cmax</sub></b>	32VDC	-I <sub>Cmax</sub> <100µA	
	Input impedance	<b>R<sub>in</sub></b>	Current limitation	See curve	

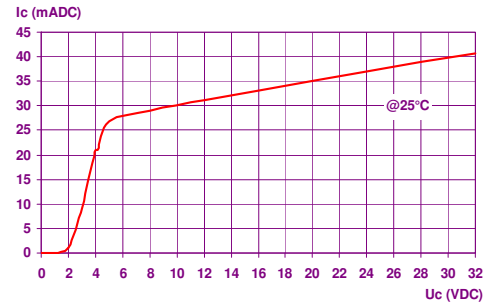

**TIME CHARACTERISTICS**

TIME CHARACT.	CHARACTERISTIC	LABEL	VALUE	Diagram	
	Turn on time	<b>ton</b>	10µs		
	Turn on delay	<b>tdon</b>	600µs		
	Turn off time	<b>toff</b>	10µs		
	Turn off delay	<b>tdoff</b>	100µs		
	Max. On-Off frequency	<b>F<sub>(on-off)</sub></b>	700Hz		

**POWER OUTPUT CHARACTERISTICS**

POWER CIRCUIT	CHARACTERISTIC	LABEL	VALUE	INFO.	
	Mains voltage range	<b>U<sub>t</sub></b>   <b>U<sub>e</sub></b>	<b>Min = VCEsat</b> <b>(Max Advised = 350VDC)</b>	Depends on protection clamping voltage (D1)	
	Non-repetitive peak voltage	<b>U<sub>tp</sub></b>	600V		
	Overvoltage protection	<b>D1</b>	Not integrated A voltage clamping mean must be connected across the terminals 1 & 2 (see fig 1 & 2)	Please consult us to select the right protective components	
	Off-state max reverse voltage drop (internal diode)	<b>-U<sub>t</sub></b>	1.4V	@I <sub>e</sub> =100A	
	Maximum nominal currents	<b>I<sub>e max</sub></b>	<b>Resistive</b> 100A	<b>Motor</b> Please contact us	<b>See fig. 9</b>
	Max. non-repetitive non-switched peak current	<b>I<sub>epeak</sub></b>	550A	@T <sub>c</sub> =100°C @T <sub>j</sub> =175°C @U <sub>tp</sub> ( <b>See fig. 8</b> )	
	Min. load current	<b>I<sub>emin</sub></b>	0mA	@T <sub>j</sub> =25°C	
	Max. leakage current	<b>I<sub>elk max</sub></b>	1mA	@U <sub>tp</sub> @T <sub>jmax</sub>	
	Voltage drop : Resistance	<b>r<sub>t</sub></b>	6.4mΩ	@T <sub>j</sub> =125°C	
	Voltage drop : Voltage	<b>v<sub>t</sub></b>	0.8V	@T <sub>j</sub> =125°C	
	Max. on-state voltage drop (Vcesat = v <sub>t</sub> + r <sub>t</sub> . I <sub>e</sub> )	<b>VCEsat</b>	1.35V @T <sub>j</sub> =25°C	1.45V @T <sub>j</sub> =125°C	@I <sub>emax</sub>
	Typ. output capacitance	<b>C<sub>out</sub></b>	300pF	@U <sub>tp</sub>	
	Junction/case thermal resistance	<b>R<sub>thjc</sub></b>	0.385K/W		
	Built-in heatsink thermal resistance vertically mounted	<b>R<sub>thra</sub></b>	10K/W	@ΔT <sub>ra</sub> =75°C	
	Heatsink thermal time constant	<b>T<sub>thra</sub></b>	10 minutes	@ΔT <sub>ra</sub> =60°C	
	Control inputs / power outputs / case insulation voltage	<b>U<sub>imp</sub></b>	4kV		
	Isolation resistance / capacitance	<b>R<sub>io</sub> / C<sub>io</sub></b>	1GΩ / <8pF		
	Maximum junction temperature	<b>T<sub>jmax</sub></b>	Steady state = 125°C	Transient = 175°C	
	Storage ambient temperature	<b>T<sub>stg</sub></b>	-40->+100°C		
	Operating ambient temperature	<b>T<sub>amb</sub></b>	-40->+90°C	<b>See fig. 9</b>	
	Max. case temperature	<b>T<sub>c</sub></b>	100°C		

**OUTPUT SWITCH CHARACTERISTIC CURVES**

**Fig. 5 VOLTAGE DROP VS LOAD CURRENT**

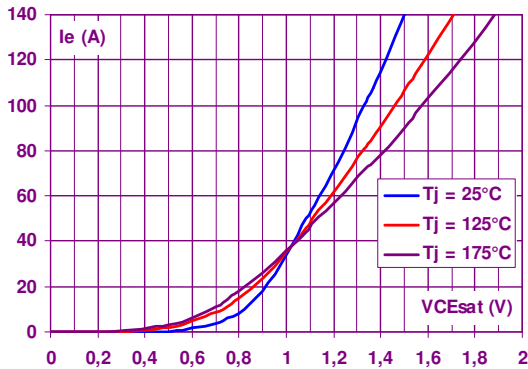

**Fig. 6 REVERSE VOLTAGE DROP VS REVERSE CURRENT**

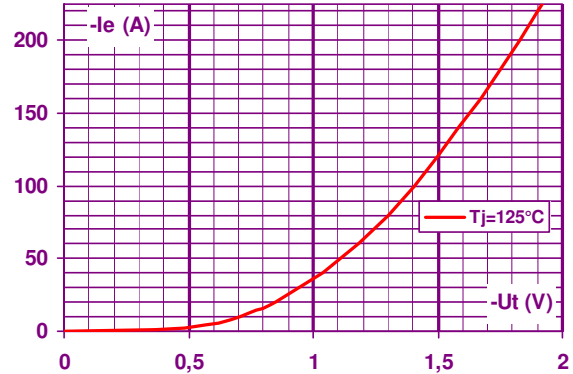

**Fig. 7 POWER ELEMENT TRANSIENT THERMAL IMPEDANCE vs. PULSE DURATION**

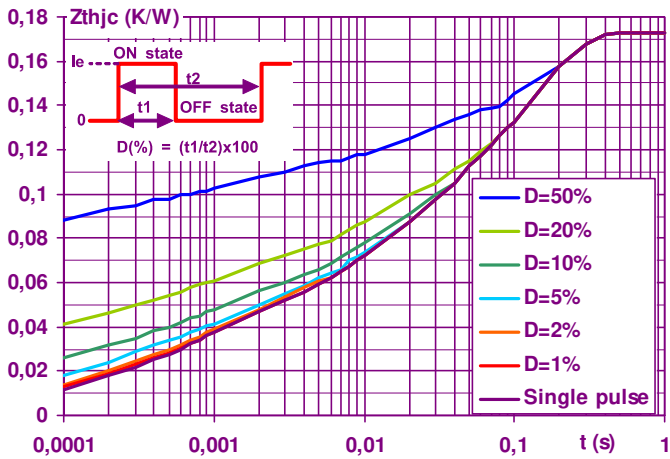

**Fig. 8 ON-STATE PEAK OVERLOAD CURRENT vs. PULSE DURATION**

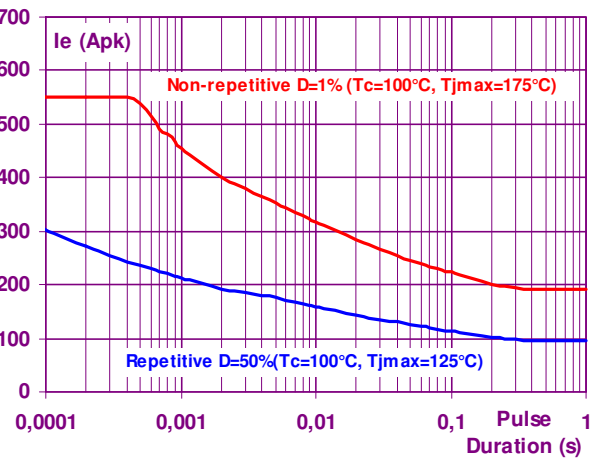

**Fig. 9 POWER DISSIPATED AND LOAD CURRENT LIMIT VS TEMPERATURE**

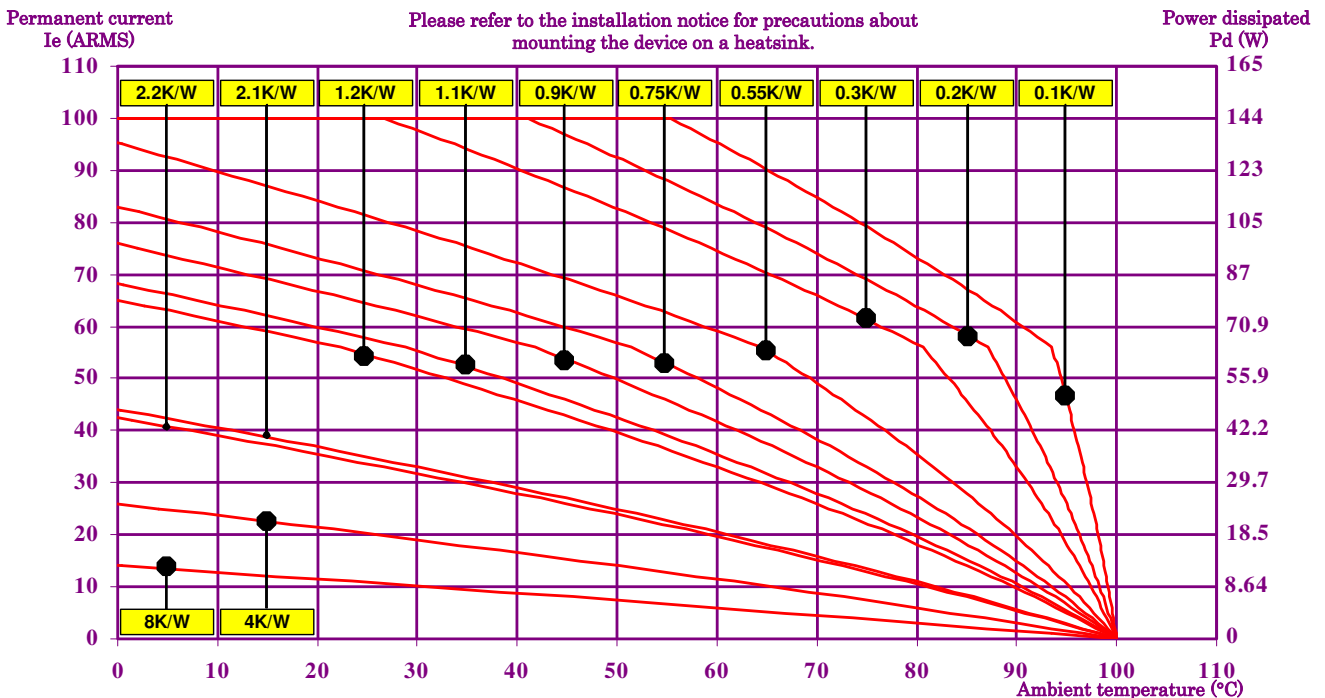

10K/W = No Heatsink / 1LD12020      4K/W = 150x150x3mm aluminium sheet      2.2K/W = WF262100 / WF151200  
 2.1K/W = WF210000      1.2K/W = WF121000      1.1K/W = WF131100      0.9K/W = WF115100      0.75K/W = WF070000  
 0.55K/W = WF050000      0.3K/W = WF031100      0.2K/W = No reference      0.1K/W = No reference

**GENERAL INFORMATION**

CONNECTIONS	Connections	Power	Control
	Screwdriver advised	Philips™ NR2	Philips™ NR1
	Min and max tightening torque	1.8 N.m	0.8 N.m
	Insulated crimp terminals (round tabs, eyelet type)	M5	M3

MISC.	Display	Green LED (indicates the power element is controlled)	
	Housing	UL94V0	
	Mounting	2 screws (M4x12mm)	See mounting sheet
	Noise level	No audible noise	
	Weight	100g	

**STANDARDS**

GENERAL	Standards	IEC60947-1
	Protection level	IP00
	Protection against direct touch	None
	CE marking	Yes
	UL, cULUS	Yes

E.M.C. IMMUNITY	TYPE OF TEST	STANDARD	LEVEL	EFFECT
	E.S.D. (Electrostatic discharges)	EN61000-4-2	Pending	?
	Radiated electromagnetic fields	EN61000-4-3	Pending	?
	Fast transients bursts	EN61000-4-4	Pending	?
	Electric chocks	EN61000-4-5	Pending	?
	Voltage drop	EN61000-4-11	-	

E.M.C. EMISSION	Radiated and conducted disturbances	NFEN55011	Pending
-----------------	-------------------------------------	-----------	---------

**DIMENSIONS AND ACCESSORIES**

Fig. 10

DIMENSIONS (mm)

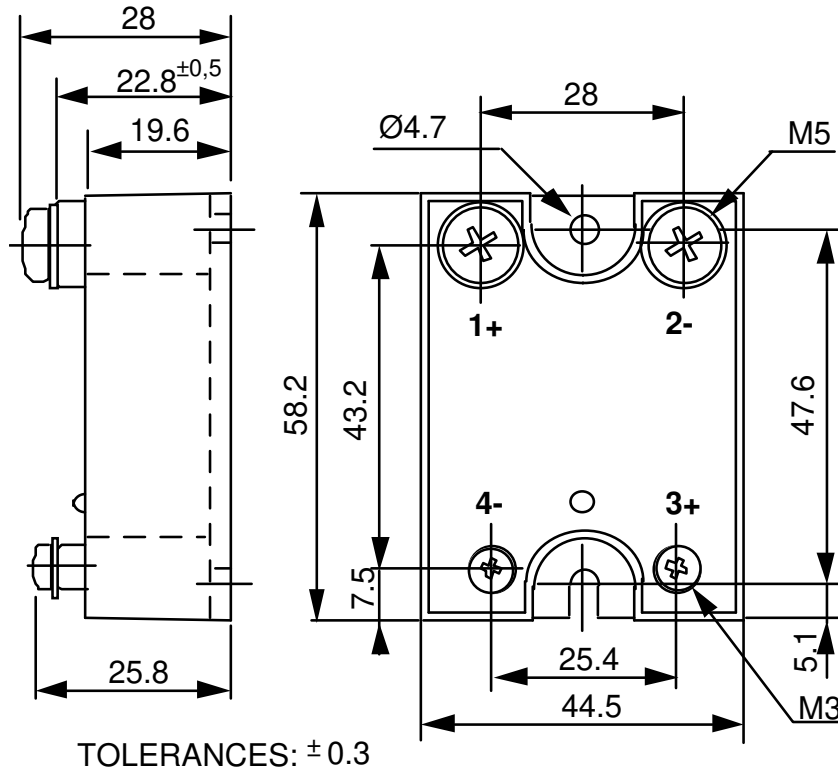

ACCESSORIES

PROTECTIVE COVER  
1K470000

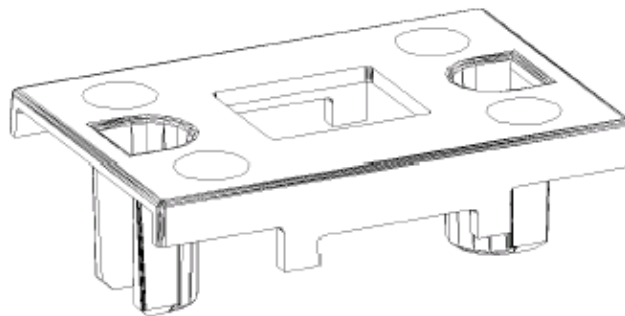

Please consult our website for other accessory references  
(Heatsinks, mounting adaptors, thermal grease...)