

**Order Number**  
**63904-2300**

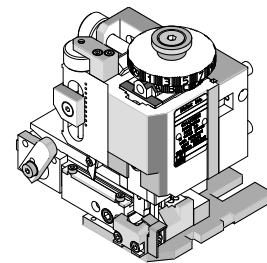

**Application Tooling Specification**

**FEATURES**

- Quick punch removal with the push of a button for fast and easy tooling change
- Applicator designed to industry-standard mounting and shut height 135.80mm (5.346")
- Quick setup time; plus, the crimp height, track and feed adjustments can be set without removing the applicator from the press
- Fine adjustment allows users to achieve target with little effort by adjusting in increments of 0.15mm (.0006") for conductor crimp height and .063mm (.0025") for insulation height
- Independent adjustment rings allow users to quickly adjust the conductor or insulation crimp height without affecting each other
- Directly adapts to most automatic wire processing machines

**SCOPE**

**Products:** Micro-Lock PLUS, 1.25mm (.049") Wire-to-Board Crimp Terminals, 26-30 AWG Wire.

Terminal Series No.	Terminal Order No.	Wire Size		Insulation Diameter				Strip Length	
				(See Note) ♦		Terminal ♦♦			
		AWG	mm <sup>2</sup>	mm	In.	mm	In.	mm	In.
505431	505431-1000 505431-1100 505431-1200 505431-1300	26-30	0.12-0.05	0.78-0.90	.031-.035	0.78-1.02	.031-.040	1.40-1.60	.055-.063

♦ To ease terminal insertion onto the connector housing, use this insulation OD range. Due to the narrow connector spacing, IPC/WHMA-A-620 crimps are not attainable.  
 ♦♦ Overall insulation OD specification for terminal.  
 Oiler (Order No. 63801-7240) is required to crimp these terminals. See FineAdjust manual (Order No. 63800-4900).

**DEFINITION OF TERMS**

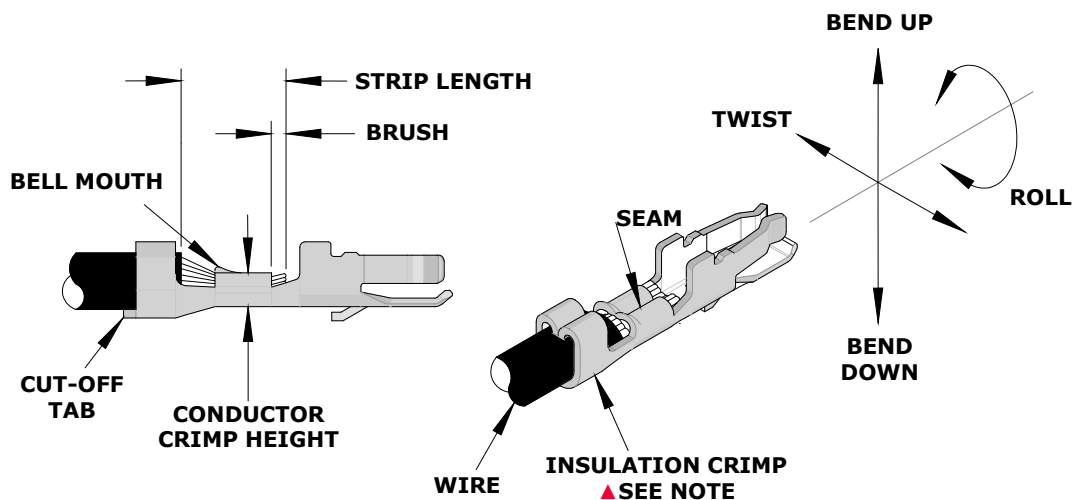

The above terminal drawing is a generic terminal representation. It is not an image of any terminal listed in the scope.

## INSULATION CRIMP FORM

This crimp terminal is designed for miniaturization; therefore, each dimension of insulation crimp portion appears small as compared to the terminal material thickness. In order to avoid insulation piercing the crimp forms by the insulation barrel, coining is provided on the inside of the insulation barrel. For this reason, various crimp forms will occur at the tip of the insulation crimp barrel shown in the figure below.

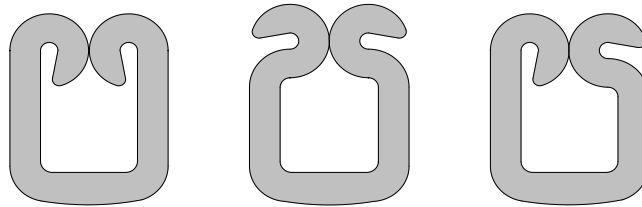

These crimp forms may be changed completely by a small change in the wire, insulation punch or terminal.

These crimp forms are satisfactory for original function of the insulation crimp portion, and it is confirmed that all of these forms represent acceptable insulation crimps.

## CRIMP SPECIFICATION

Terminal Series No.	Bell Mouth		Cut-Off Tab Maximum		Conductor Brush	
	mm	In.	mm	In.	mm	In.
505431	0.10-0.30	.004-.012	0.10	.004	0.10-0.30	.004-.012

Terminal Series No.	Bend Up	Bend Down	Twist	Roll	Punch Width mm (Ref)				Seam
	Degree	Degree	Degree	Degree	Conductor		Insulation		
					mm	In.	mm	In.	
505431	2	3	3	4	0.85	.034	0.90	.035	Seam shall not be open and no wire allowed out of the crimping area

After crimping, the conductor profile should measure the following:

Terminal Series No.	Wire Size	Conductor Crimp Height		Pull Force Minimum	
	AWG	mm	In.	N	Lb.
505431	26	0.54-0.59	.021-.023	19.6	4.40
	28	0.49-0.54	.019-.021	9.8	2.20
	30	0.46-0.51	.018-.020	4.9	1.10

Terminal Series No.	Wire Size	Insulation			
		Crimp Height (Ref.)		Crimp Width (Ref.)	
	AWG	mm	In.	mm	In.
505431	26	1.35	.053	1.00	.039
	28	1.30	.051	1.00	.039
	30	1.25	.049	1.00	.039

### Tool Qualification Notes

1. Pull force should be measured with no influence from the insulation crimp.
2. The above specifications are guidelines to an optimum crimp.

**PARTS LIST**

<b>FineAdjust Applicator 63904-2300</b>				
<b>Item</b>	<b>Order No.</b>	<b>Engineering No.</b>	<b>Description</b>	<b>Quantity</b>
<b>Perishable Tooling</b>				
	63904-2370	63904-2370	Tool Kit (All "Y" Items)	REF
1	200216-0804	200216-0804	Conductor Punch	1 Y
2	63455-0135	63455-0135	Conductor Anvil	1 Y
3	63446-0905	63446-0905	Insulation Punch	1 Y
4	63443-0005	63443-0005	Cut-Off Plunger	1 Y
5	63443-0012	63443-0012	Front Plunger Retainer	1 Y
<b>Other Components</b>				
6	11-18-4083	60707-8	Feed Guide	1
7	11-24-1067	4996-4	Cut-Off Plunger Spring	1
8	63443-0009	63443-0009	Front Scrap Chute	1
9	63443-0024	63443-0024	Key	1
10	63443-0090	63443-0090	Wire Stop	1
11	63443-2217	63443-2217	Coarse Spacer (17.00mm)	1
12	63443-2309	63443-2309	Fine Spacer (3.45mm)	1
13	63443-2806	63443-2806	Front Plunger Striker	1
14	63443-2904	63443-2904	Wire Hold Down Plunger	1
15	63443-6108	63443-6108	Rear Cover	1
16	63600-0021	63600-0021	Compression Spring	1
17	63443-1746	63443-1746	Height Spacer (19.00mm)	1
<b>Frame</b>				
18	63800-4901	63800-4901	Top	1
19	63801-3281	63801-3281	Base	1
20	63801-4650	63801-4650	Track	1
<b>Hardware</b>				
21	—	—	M3 by 6 Long SHCS	2*
22	—	—	M3 by 6 Long FHCS	1*
23	—	—	M4 by 6 Long SHCS	2*
24	—	—	M4 by 12 Long BHCS	2*
25	—	—	M4 by 45 Long SHCS	2*
26	—	—	M5 by 12 Long SHCS	1*
27	—	—	#10-32 by 3/8" Long Flat Point SSS	1*
28	—	—	#10-32 Hex Jam Nut	1*
* Available from an industrial supply company.				

**ASSEMBLY DRAWING**

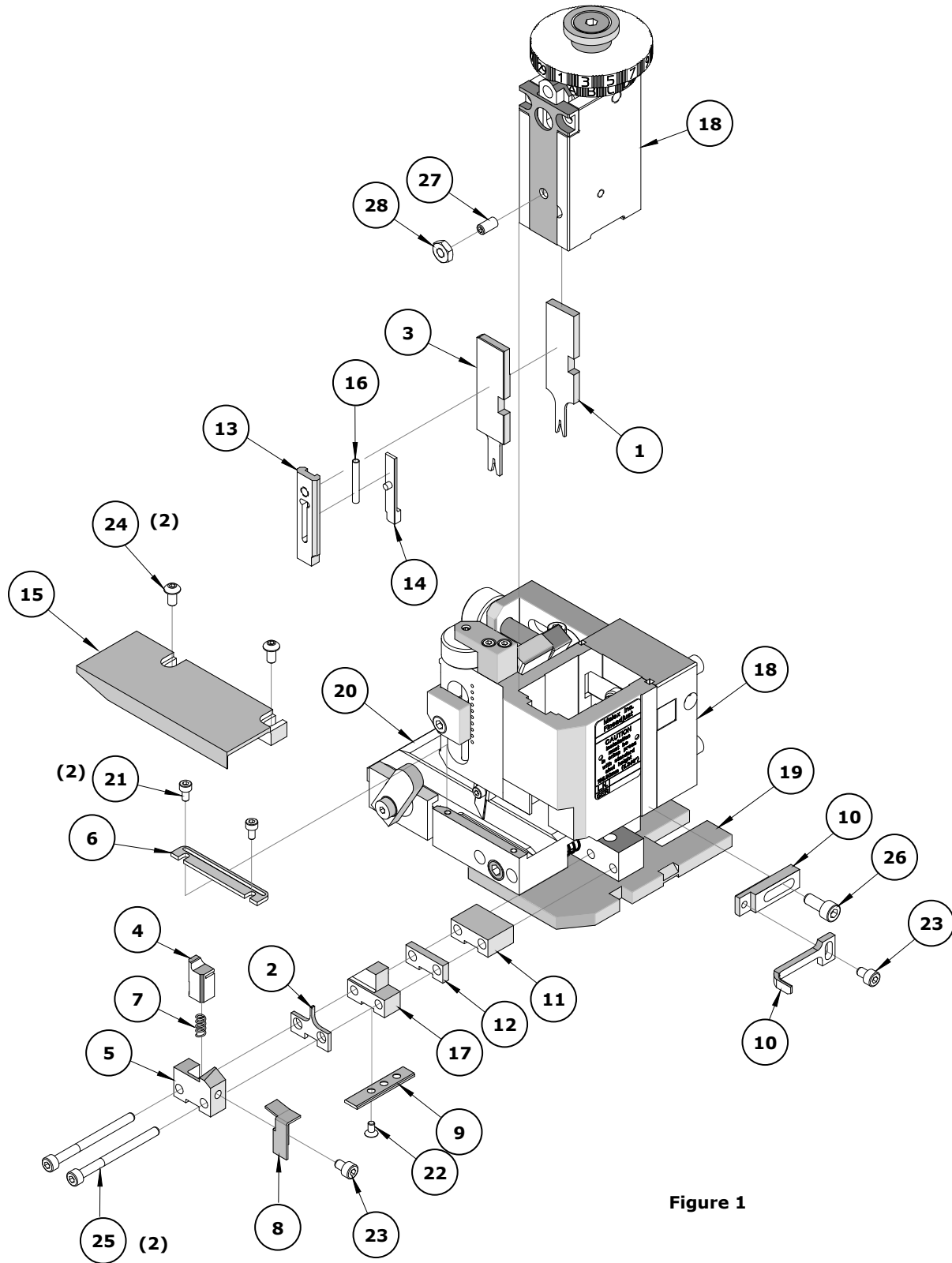

## NOTES

---

1. Molex recommends that an extra perishable tooling kit be maintained at your facility.
2. Verify tooling alignment by manually cycling the press and applicator before crimping under power. Check that all screws are tight.
3. Slugs, terminals, dirt and oil should be kept clear of the work area.
4. Wear safety glasses at all times.
5. For recommended maintenance, refer to the FineAdjust manual.

**CAUTION:** This applicator should only be used in a press with a shut height of 135.8mm (5.346"). Tooling damage could result at a lower setting.

**CAUTION:** To prevent injury, never operate this applicator without the guards supplied with the press or wire-processing machine in place. Reference the press or wire-processing manufacturer's instruction manual.

**CAUTION:** Molex crimp specifications are valid only when used with Molex terminals, applicators and tooling.

### Application Tooling Support

**Phone:** (402) 458-TOOL (8665)  
**E-Mail:** [toolingsupport@molex.com](mailto:toolingsupport@molex.com)  
**Website:** [www.molex.com/applicationtooling](http://www.molex.com/applicationtooling)

Molex is a registered trademark of Molex, LLC in the United States of America and may be registered in other countries; all other trademarks listed herein belong to their respective owners.