

LOC	DIST	REVISIONS			
GP	00	REV	DATE	BY	CHK
		A	25AUG2015	RG	SH
		B	7JUL2017	RG	SH
		C	20JUL2017	RG	SH
		D	04APR2018	TX	SH

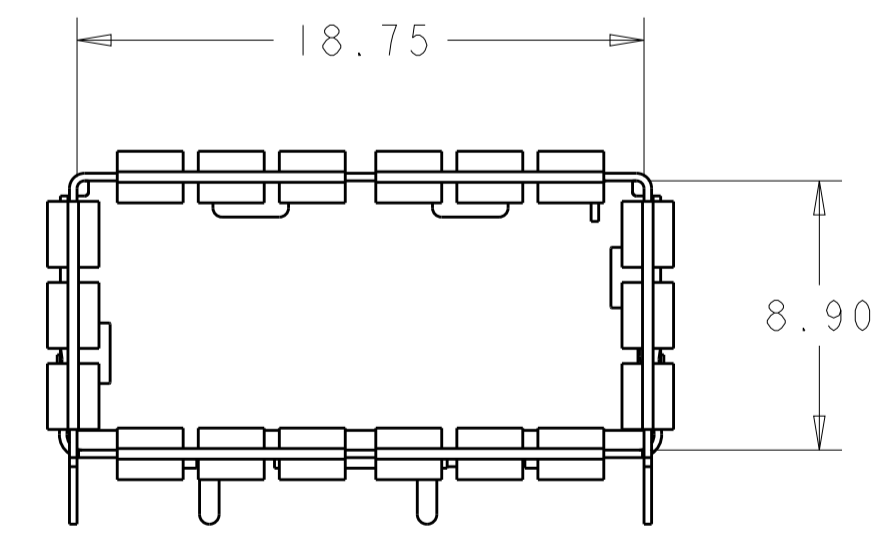
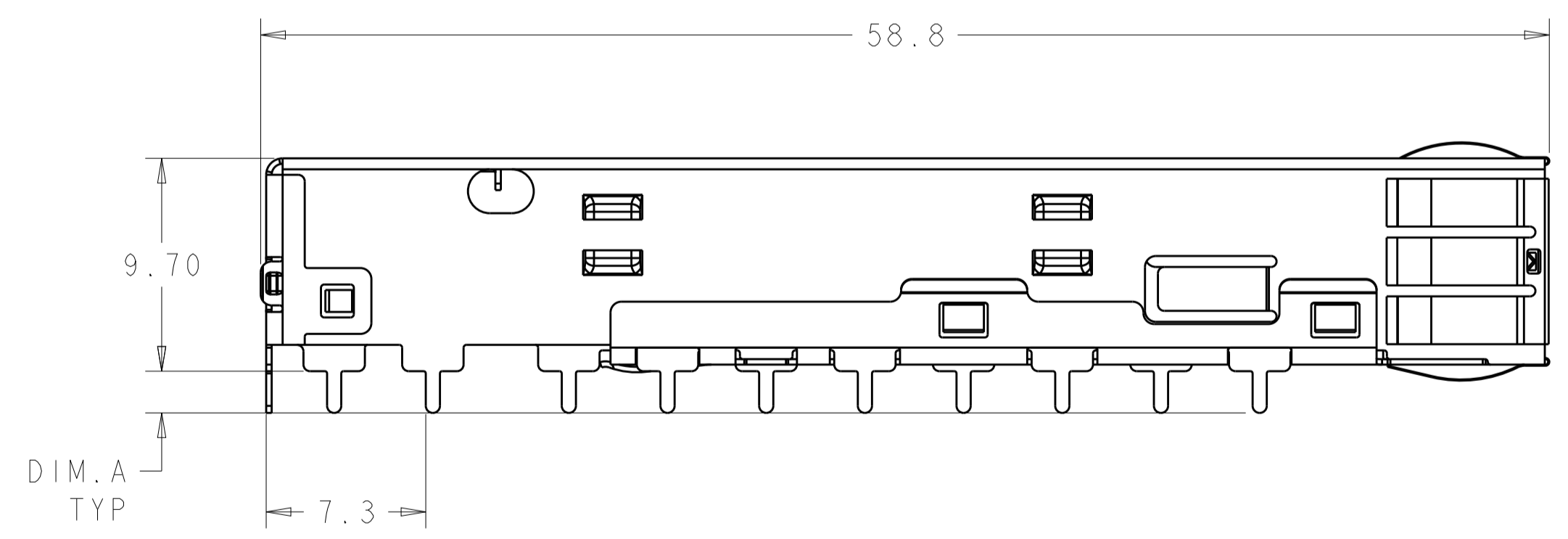
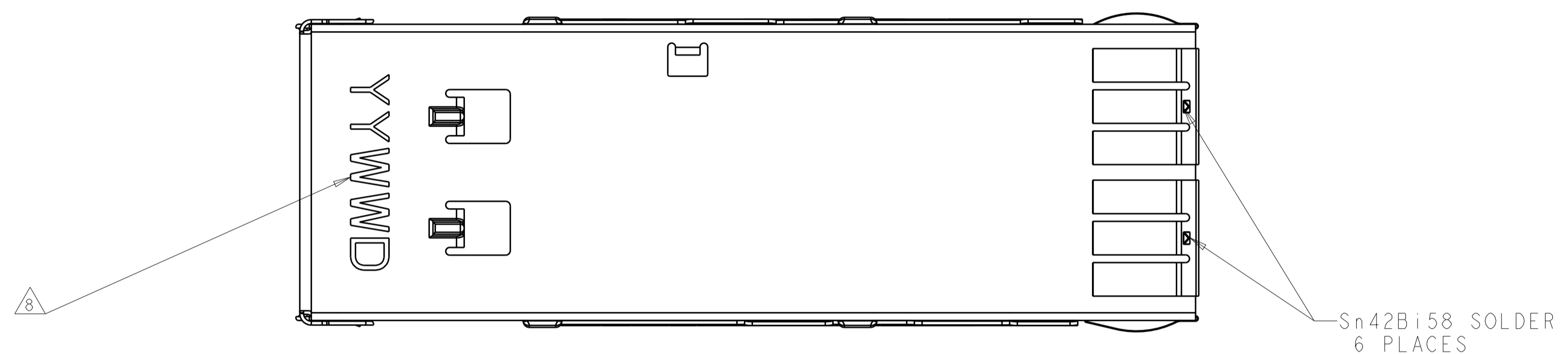
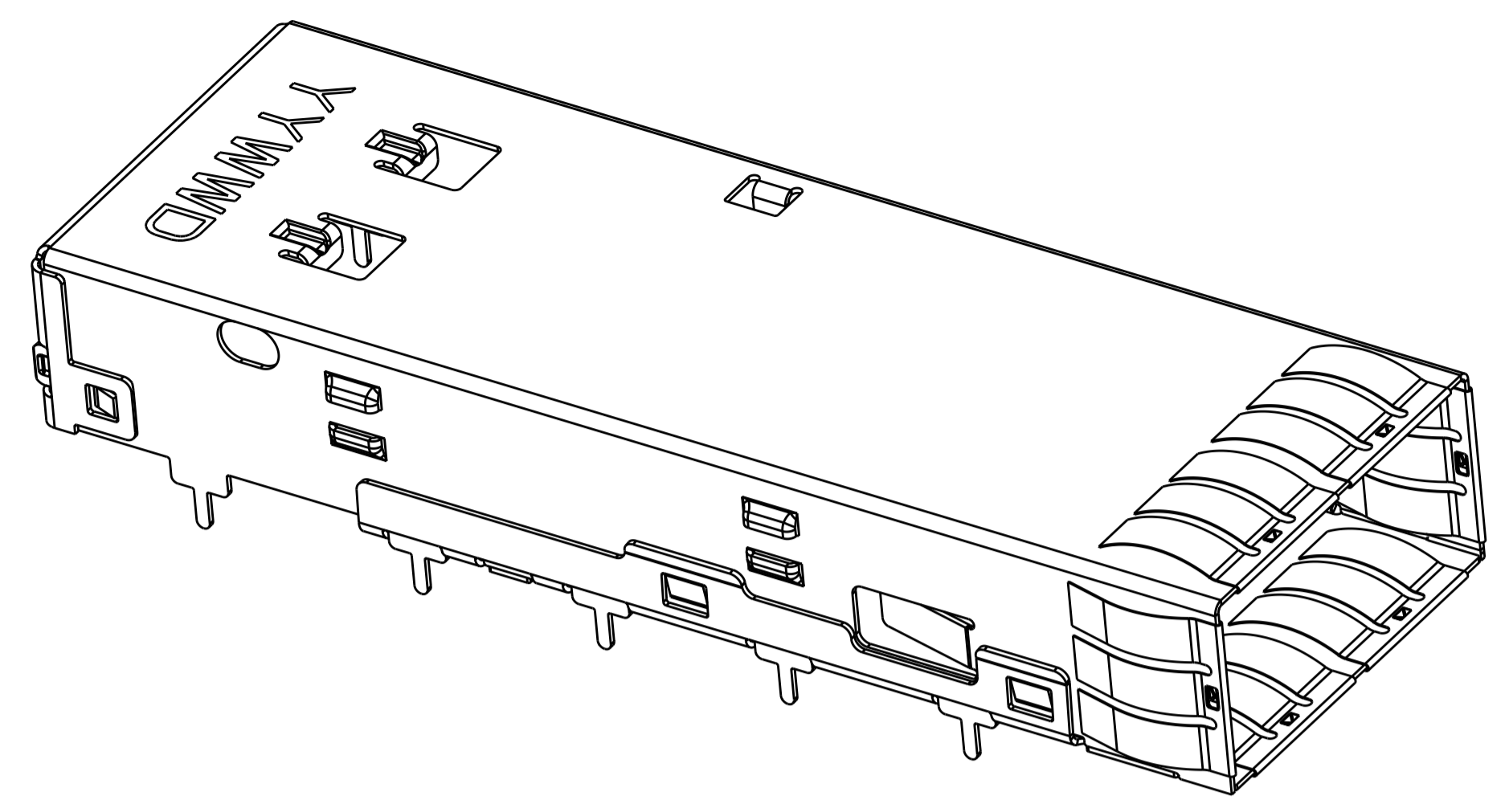

- △ MATERIAL:
 CAGE - 0.25 THICK CuNiSi 1.25μm MINIMUM TIN PER 112-16-4 OVER 0.125μm MINIMUM NICKEL PER 112-25-2.
 OR 0.25 THICK NICKEL SILVER ALLOY
 SPRINGS - COPPER ALLOY
 HEAT SINK - ALUMINUM
 HEAT SINK CLIP - STAINLESS STEEL
- △ MINIMUM PITCH DIMENSION.
- 3. MATES WITH QSPF MSA COMPATIBLE TRANSCEIVER.
- △ DATUM AND BASIC DIMENSIONS ESTABLISHED BY CUSTOMERS.
- 5. MINIMUM PC BOARD THICKNESS:
 SINGLE SIDED: 1.45mm
 DOUBLE SIDED: 2.2mm
- △ DATUM [-A-] IS TOP SURFACE OF THE HOST BOARD.
- △ SURFACE TRACES PERMITTED WITHIN THIS AREA EXCEPT WHERE CAGE STANDOFFS, SHOWN IN DETAIL J, CONTACT PC BOARD.
- △ DATE CODE (YYWWDD) MARKED APPROXIMATELY AS SHOWN.
- △ FINISH:
 SPRINGS - TIN PLATING OVER NICKEL, NON-PLATED EDGES PERMISSIBLE.
 HEAT SINK - BLACK ANODIZED
- △ DIMENSION APPLIES WITH MODULE INSTALLED IN THE CAGE.

TIN PLATING OVER ALL	2.60	C70260 Cu Ni Si	2170322-6
TIN DIPPING ON TAIL	1.90	C77000 NICKEL SILVER ALLOY	2170322-3
TIN PLATING OVER ALL	1.90	C70260 Cu Ni Si	2170322-1
TREATMENT	DIM. A	CAGE MATERIAL	PART NUMBER

THIS DRAWING IS A CONTROLLED DOCUMENT.		OWN: PETER PAN 04FEB2013	STE TE Connectivity
DIMENSIONS: mm		CHK: JASON YANG 04FEB2013	
TOLERANCES UNLESS OTHERWISE SPECIFIED:		APPV: AILEY CAI 04FEB2013	
0 PLC ±0.25 1 PLC ±0.25 2 PLC ±0.20 3 PLC ± 4 PLC ± ANGLES ±°		NAME: QSPF IXI CAGE ASSEMBLY SOLDER, THRU BEZEL PRODUCT SPEC: 108-2286 APPLICATION SPEC: 114-13217 WEIGHT: - CUSTOMER DRAWING	
MATERIAL: △		FINISH: △	SIZE: A1 CAGE CODE: 00779 DRAWING NO: C=2170322 RESTRICTED TO: - SCALE: 2:1 SHEET 1 OF 6 REV D

LOC		DIST		REVISIONS			
GP	00	P	LTN	DESCRIPTION	DATE	DMN	APVD
-	-	-	-	SEE SHEET 1	-	-	-

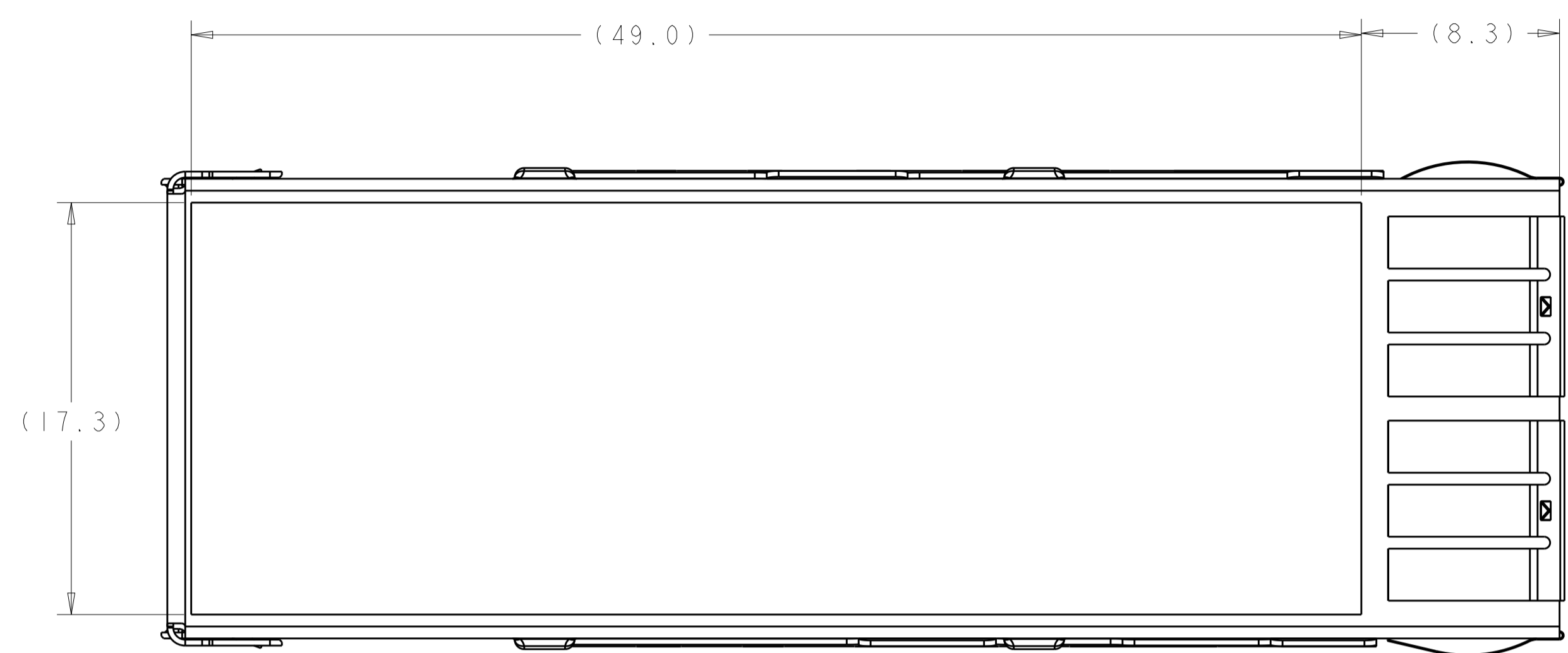

1-2170322-0 BE SAEM TO 2170322-1 EXCPET WITH THE FILM

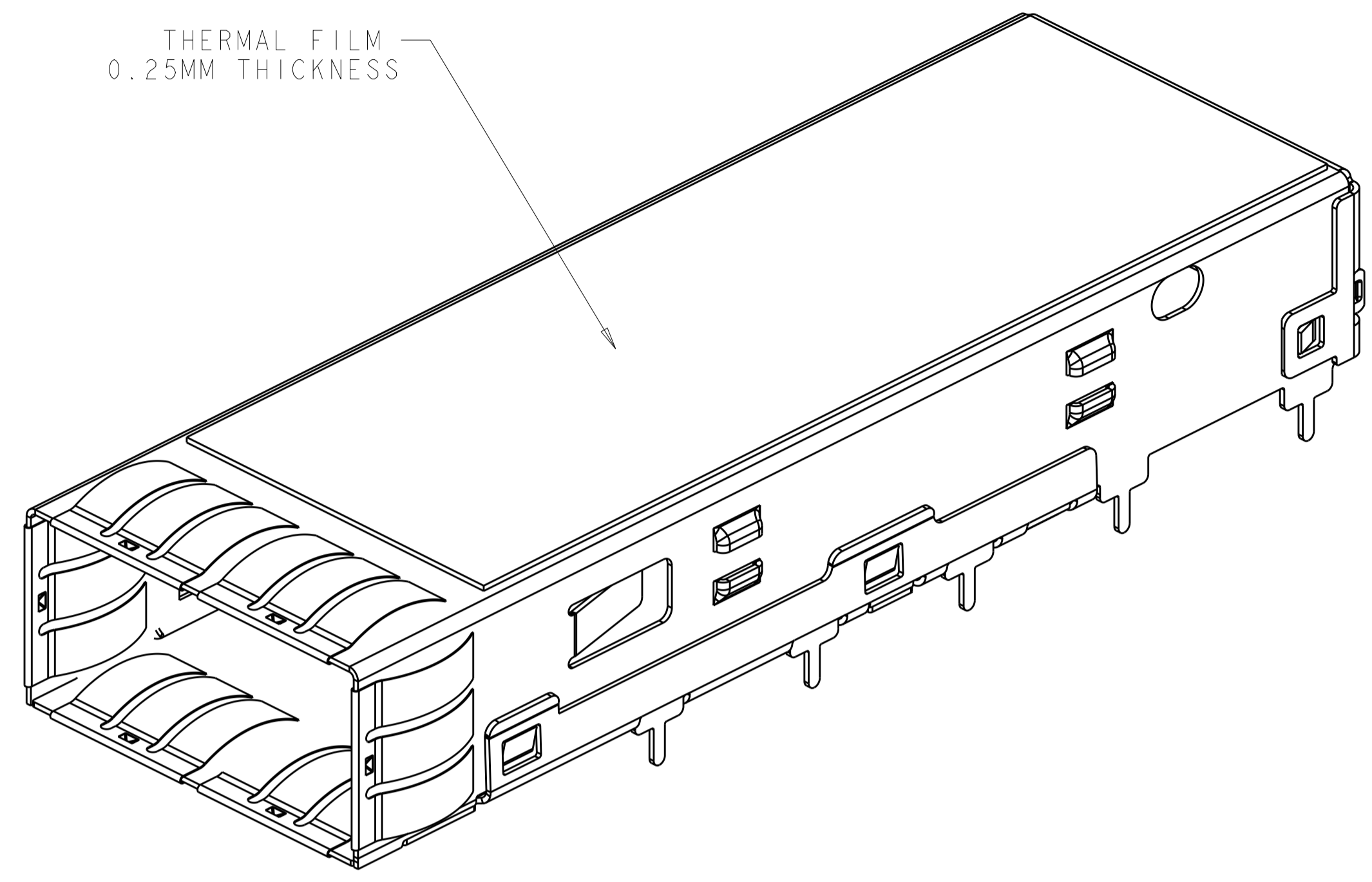

1-2170322-0 AS SHOWN
SCALE 5:1

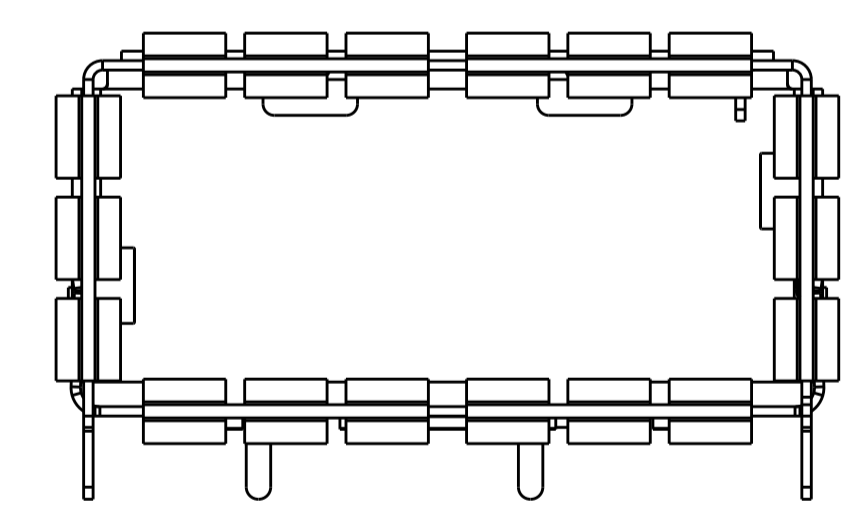
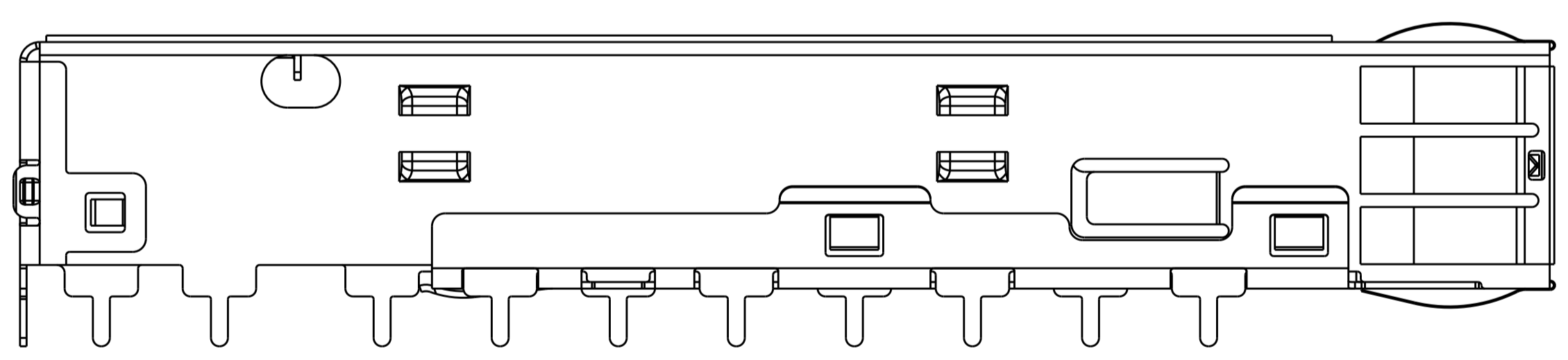

SCALE 5:1

TIN PLATING OVER ALL TREATMENT	C70260 Cu Ni Si	1-2170322-0
	CAGE MATERIAL	PART NUMBER

THIS DRAWING IS A CONTROLLED DOCUMENT.		DMN: PETER PAN 04FEB2013	TE Connectivity
DIMENSIONS: mm		CHK: JASON YANG 04FEB2013	
TOLERANCES UNLESS OTHERWISE SPECIFIED:		APVD: AILEY CAI 04FEB2013	
0 PLC ±0.25 1 PLC ±0.25 2 PLC ±0.20 3 PLC ± 4 PLC ± ANGLES ±°		NAME: OSFP PRODUCT SPEC: 108-2286 APPLICATION SPEC: 114-13217 WEIGHT: - CUSTOMER DRAWING	
MATERIAL: -		FINISH: -	SIZE: A1 CAGE CODE: 00779 DRAWING NO: C=2170322 RESTRICTED TO: - SCALE: 2:1 SHEET 2 OF 6 REV D

LOC	DIST	REVISIONS					
GP	00	P.	LYR	DESCRIPTION	DATE	DWN	APVD
-	-	-	-	SEE SHEET 1	-	-	-

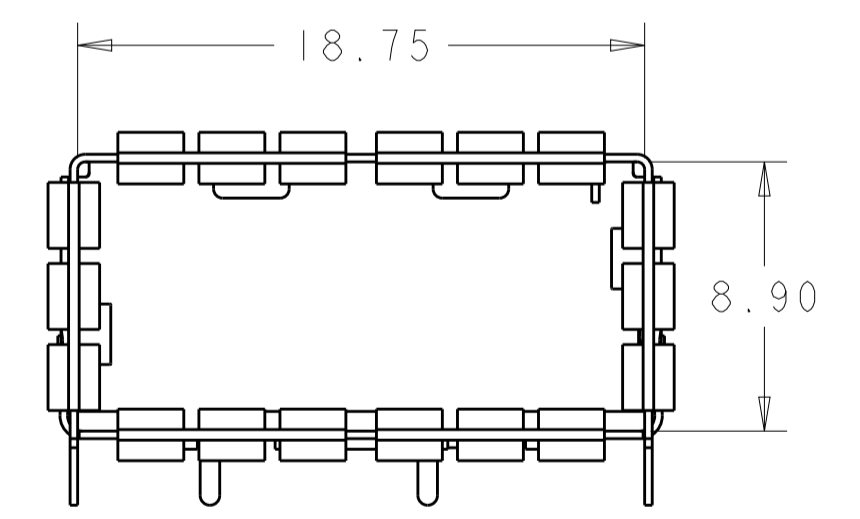
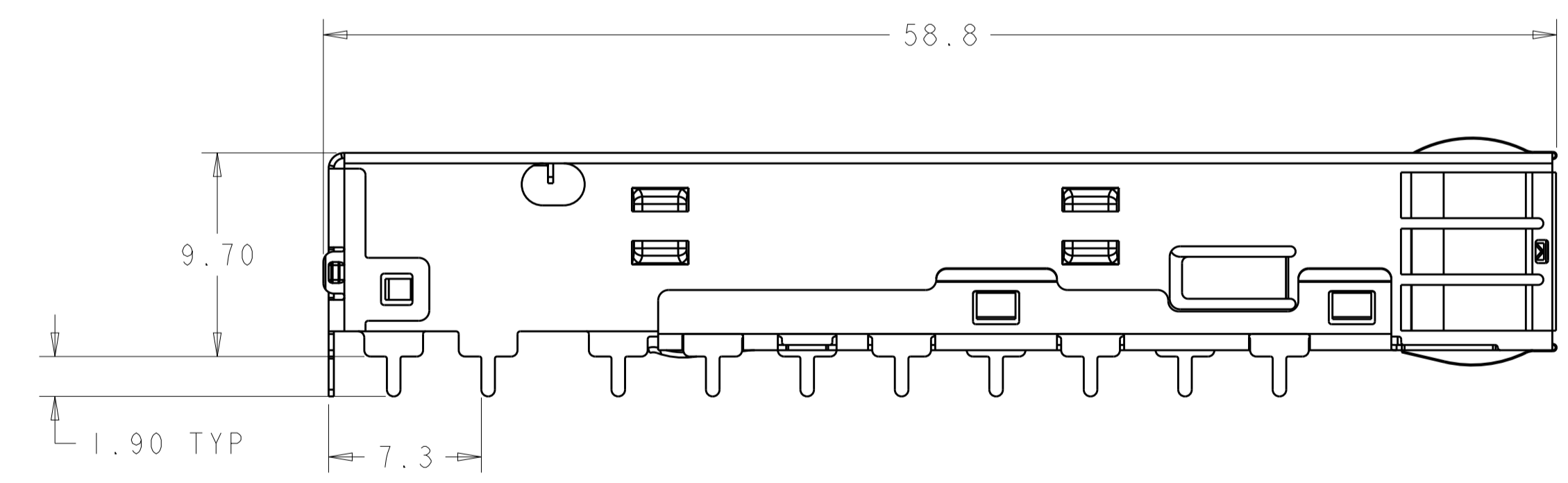
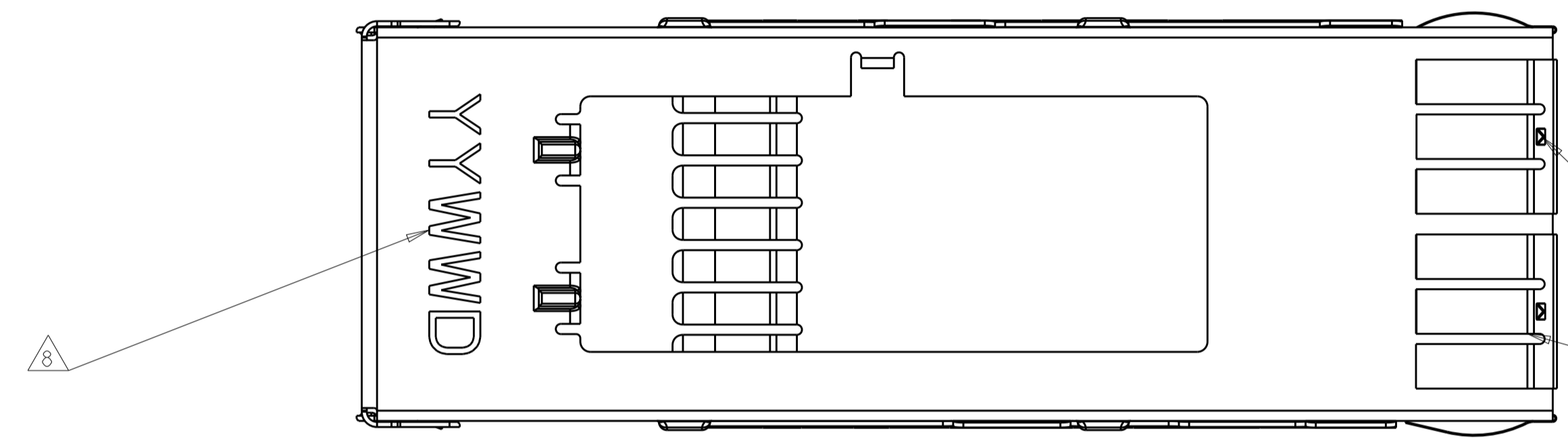
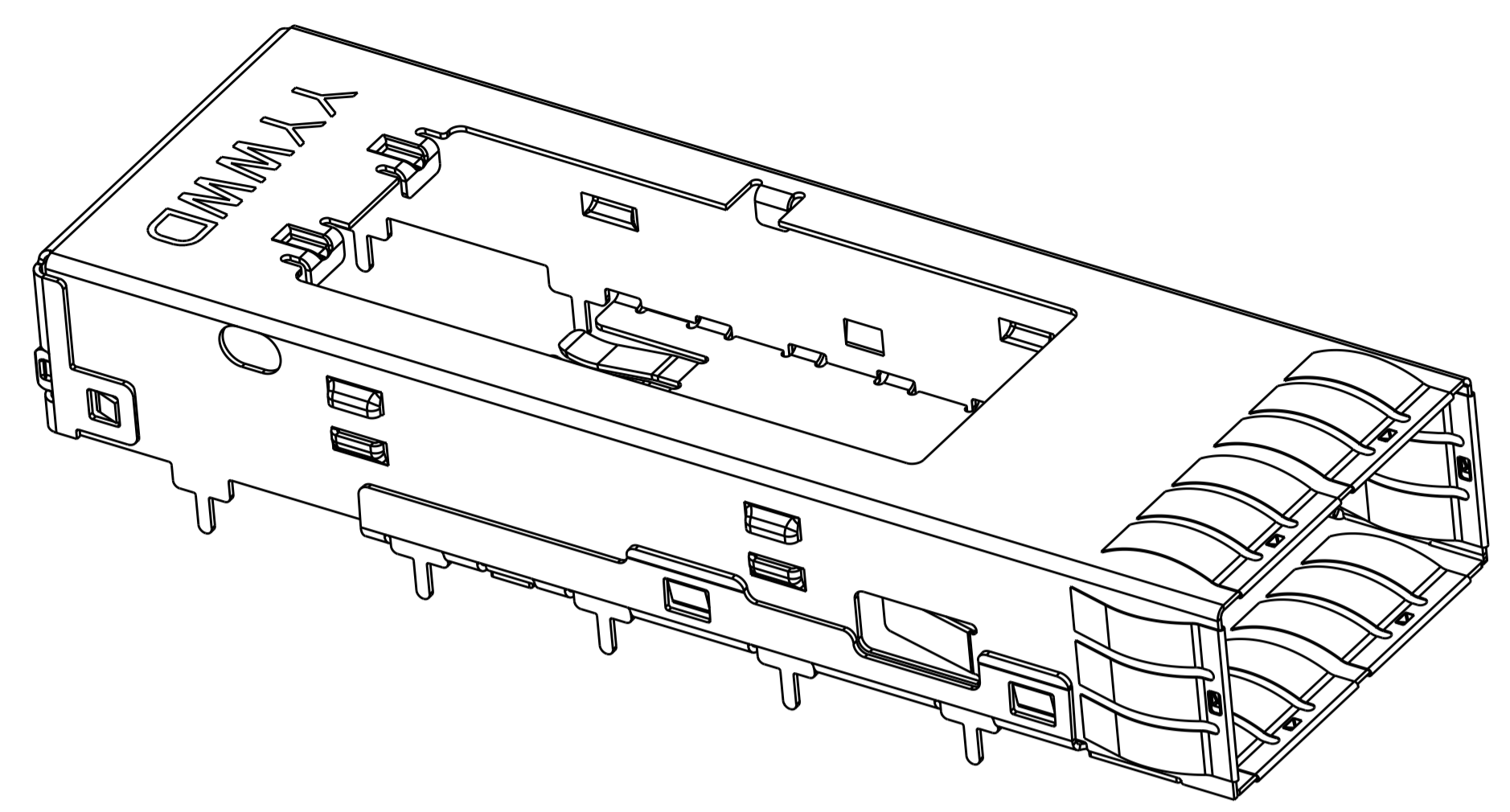

	TIN PLATING OVER ALL TREATMENT	C70260 Cu Ni Si CAGE MATERIAL	2170322-2 PART NUMBER
--	--------------------------------	-------------------------------	-----------------------

THIS DRAWING IS A CONTROLLED DOCUMENT.		OWN: PETER PAN 04FEB2013	TE Connectivity
DIMENSIONS: mm		CHK: JASON YANG 04FEB2013	
TOLERANCES UNLESS OTHERWISE SPECIFIED:		APVD: AILEY CAI 04FEB2013	NAME: QSFP IXI CAGE ASSEMBLY SOLDER, THRU BEZEL
0 PLC ±0.25 1 PLC ±0.25 2 PLC ±0.20 3 PLC ± 4 PLC ± ANGLES ±45°		PRODUCT SPEC: 108-2286	SIZE: A1
MATERIAL: -		APPLICATION SPEC: 114-13217	CAGE CODE: 2170322
FINISH: -		WEIGHT: -	RESTRICTED TO: -
CUSTOMER DRAWING		SCALE: 2:1	SHEET 3 OF 6 REV D

LOC	DIST	REVISIONS					
		P.	LYR	DESCRIPTION	DATE	OWN	APVD
GP	00	-	-	SEE SHEET 1	-	-	-

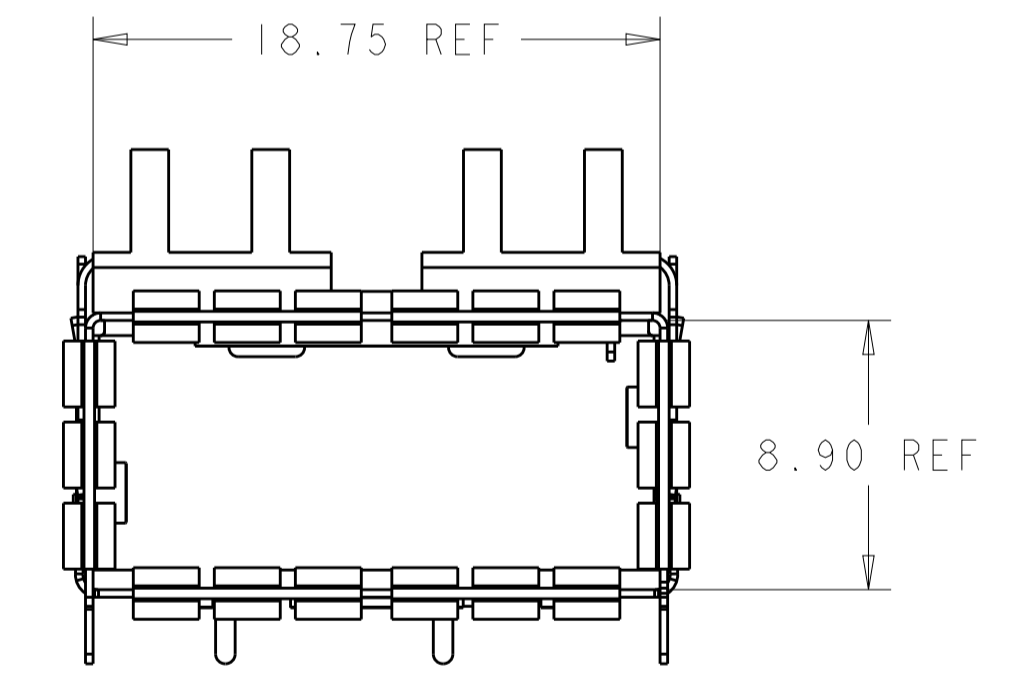
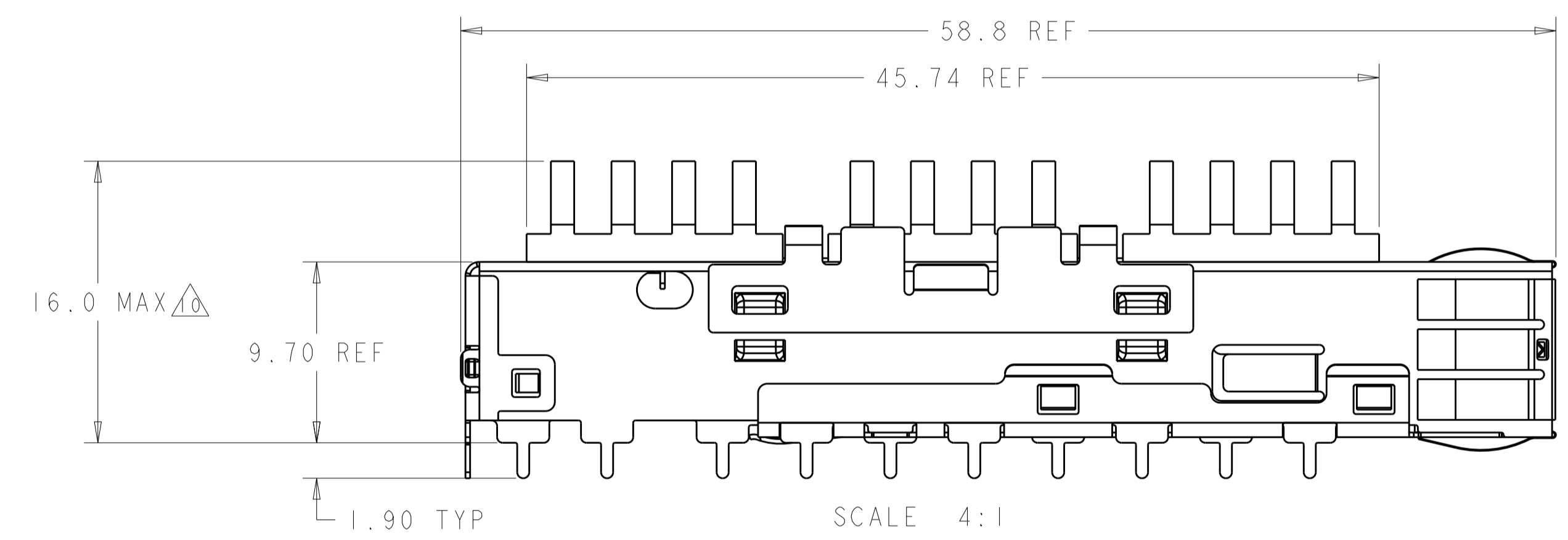
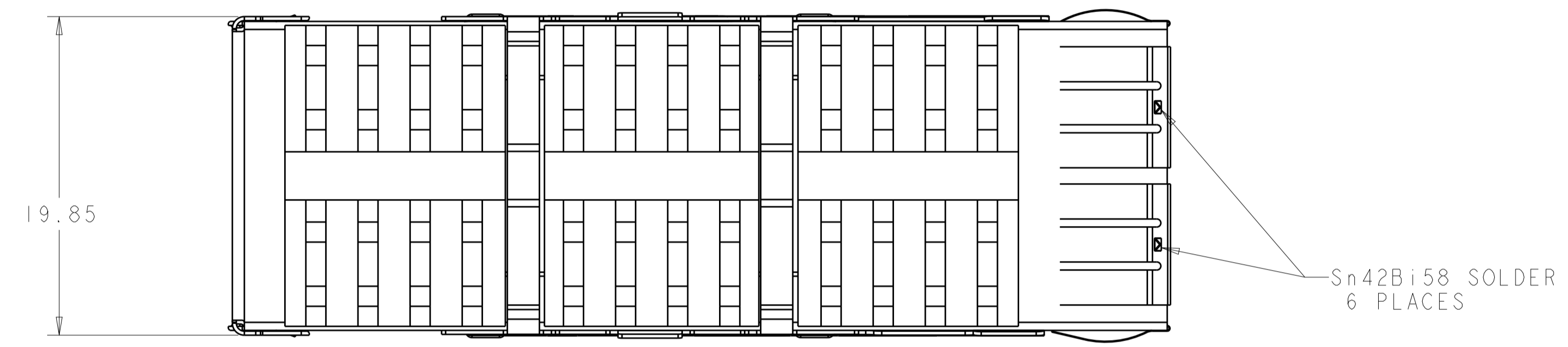
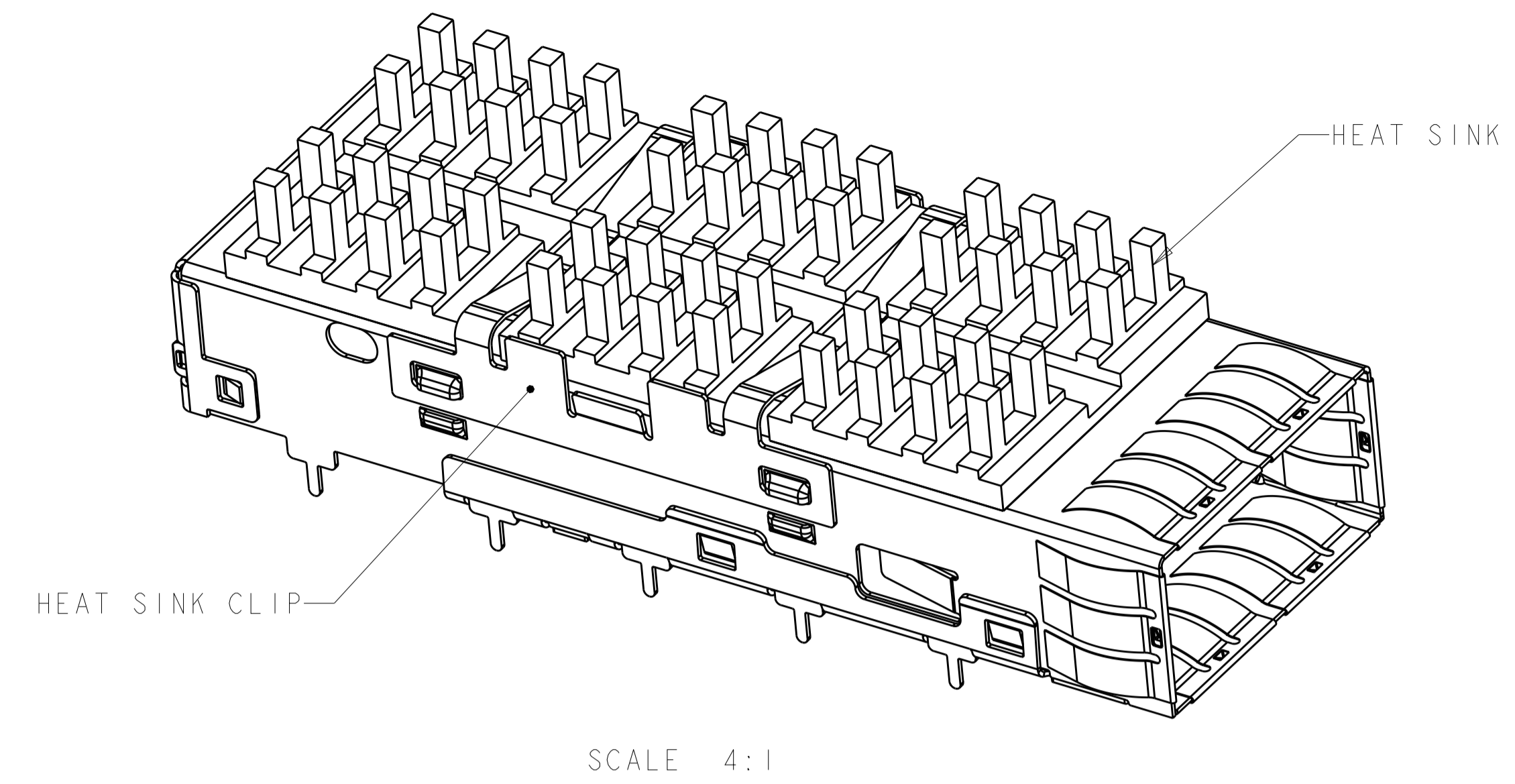

Δ TIN DIPPING ON TAIL	C77000 NICKEL SILVER ALLOY	2170322-5
TIN PLATING OVER ALL	C70260 Cu Ni Si	2170322-4
TAIL TREATMENT	CAGE MATERIAL	PART NUMBER

THIS DRAWING IS A CONTROLLED DOCUMENT.		OWN: PETER PAN 04FEB2013	TE Connectivity
DIMENSIONS:		CHK: JASON YANG 04FEB2013	
TOLERANCES UNLESS OTHERWISE SPECIFIED:		APVD: AILEY CAI 04FEB2013	
0 PLC ± 0.25 1 PLC ± 0.25 2 PLC ± 0.25 3 PLC ± 0.20 4 PLC \pm ANGLES \pm FINISH $\pm 45^\circ$		NAME: OSFP PRODUCT SPEC: 108-2286 APPLICATION SPEC: 114-13217 WEIGHT: - CUSTOMER DRAWING	
MATERIAL: -		SIZE: A100779	CAGE CODE: C=2170322 DRAWING NO: - RESTRICTED TO: - SCALE: 2:1 SHEET 4 OF 6 REV D

LOC	DIST	REVISIONS					
GP	00	P	LYR	DESCRIPTION	DATE	DMN	APVD
-	-	-	-	SEE SHEET 1	-	-	-

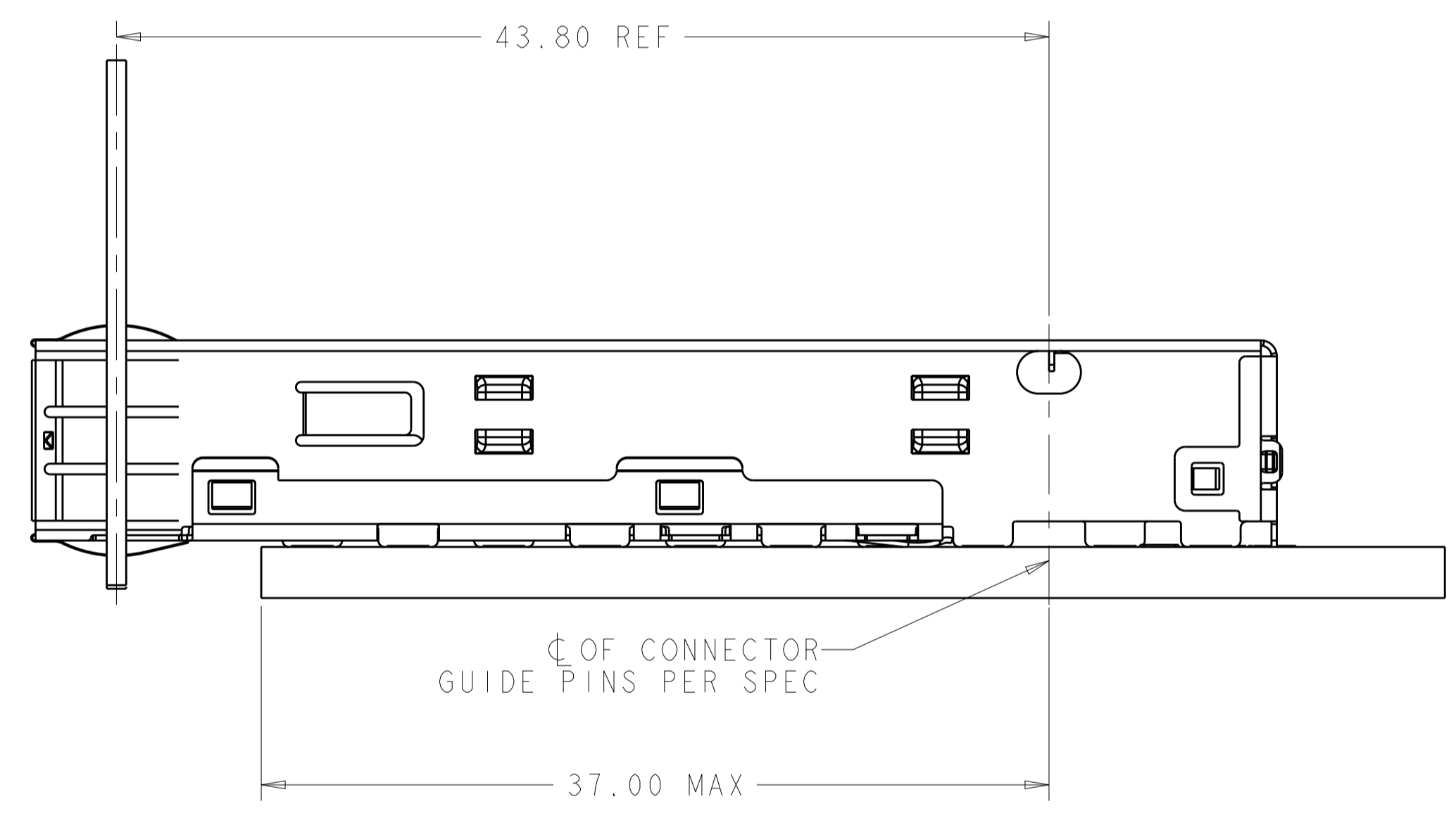
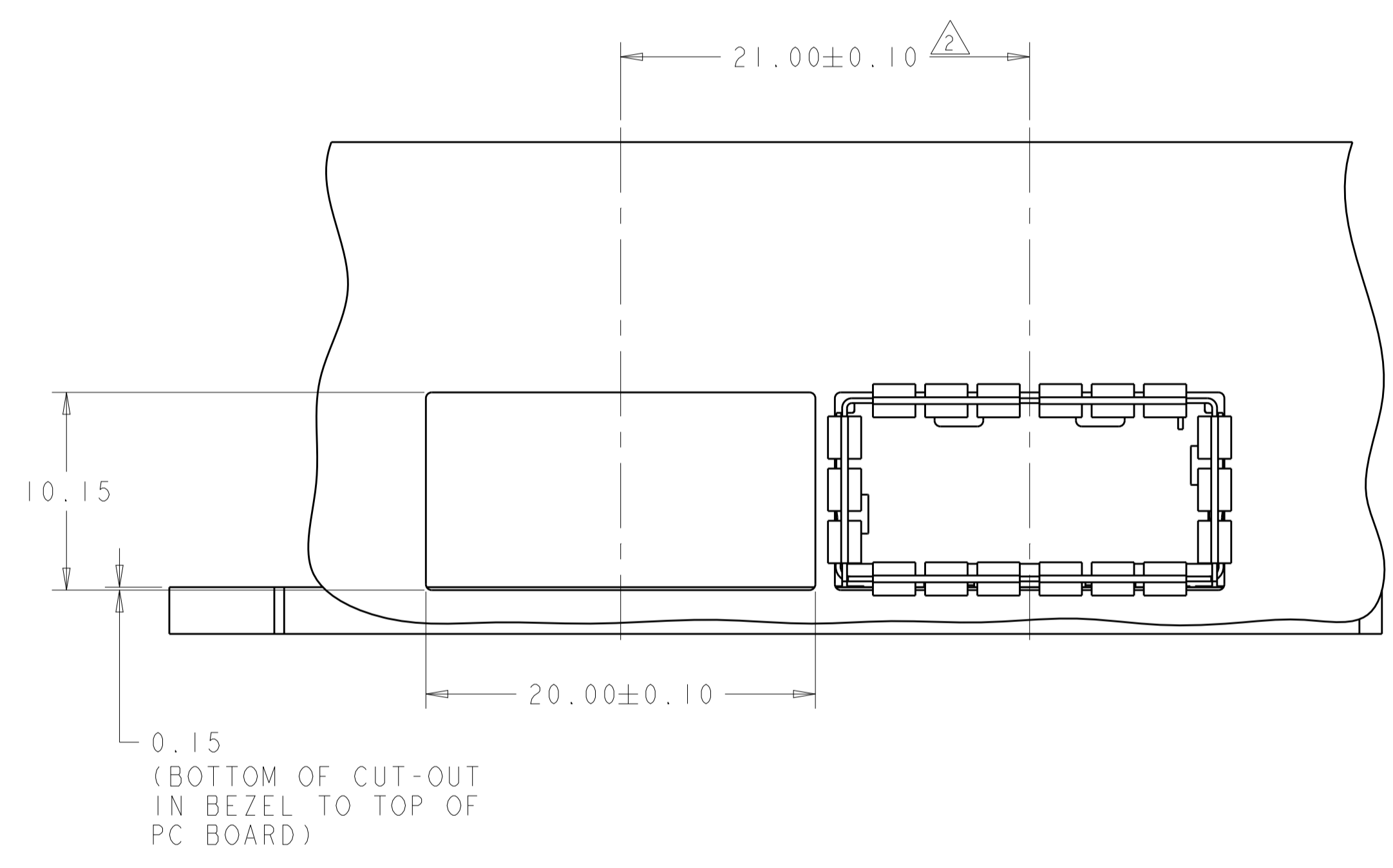

THIS DRAWING IS A CONTROLLED DOCUMENT.		DMN: PETER PAN 04FEB2013	TE Connectivity
DIMENSIONS: mm		CHK: JASON YANG 04FEB2013	
TOLERANCES UNLESS OTHERWISE SPECIFIED:		APVD: ALEY CAI 04FEB2013	NAME: OSFP
0 PLC ±0.25	1 PLC ±0.25	PRODUCT SPEC	IXI CAGE ASSEMBLY
2 PLC ±0.20	3 PLC ±0.20	108-2286	SOLDER, THRU BEZEL
4 PLC ±0.20	ANGLES ±0.5°	APPLICATION SPEC	SIZE: CAGE CODE DRAWING NO
MATERIAL: -	FINISH: -	114-13217	RESTRICTED TO
CUSTOMER DRAWING		WEIGHT: -	A100779C=2170322
SCALE: 2:1		SHEET 5 OF 6 REV D	

LOC	DIST	REVISIONS			
GP	00	REV	DATE	BY	APPV
		1	SEE SHEET 1		

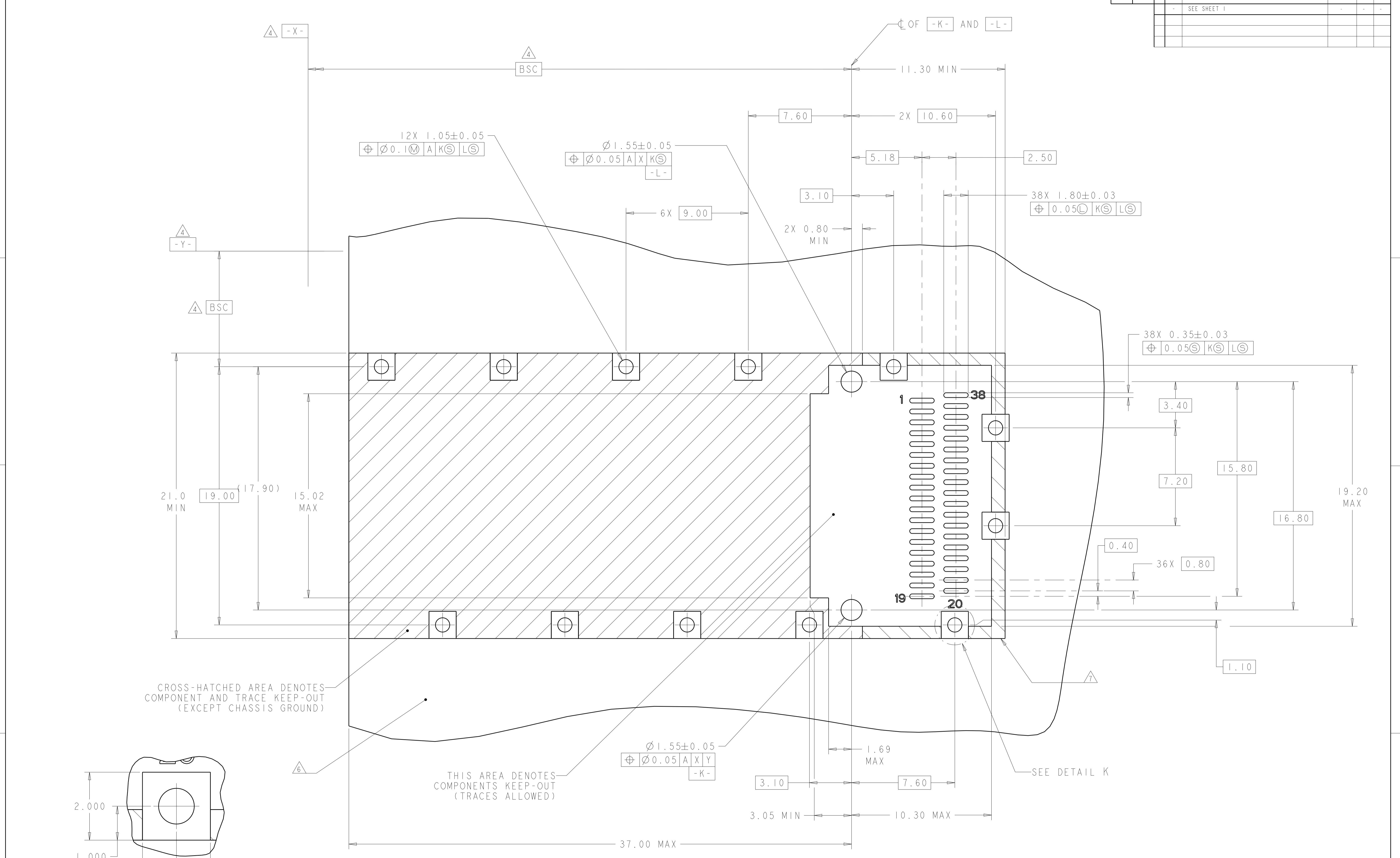

CROSS-HATCHED AREA DENOTES COMPONENT AND TRACE KEEP-OUT (EXCEPT CHASSIS GROUND)

THIS AREA DENOTES COMPONENTS KEEP-OUT (TRACES ALLOWED)

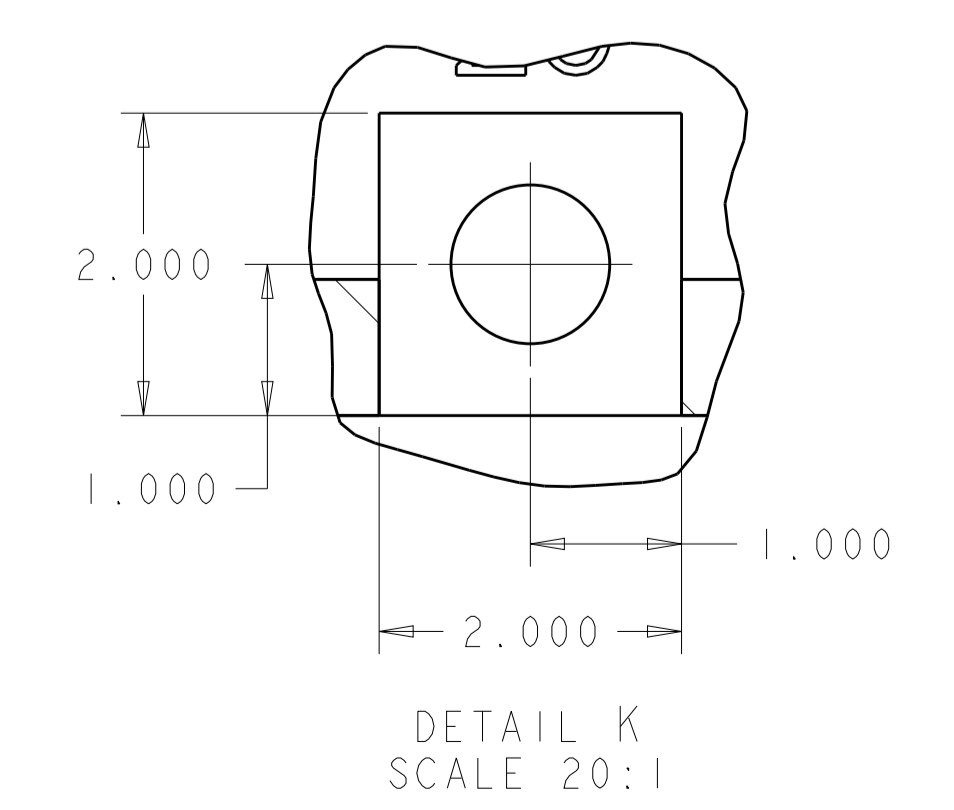

RECOMMENDED PC BOARD LAYOUT
SCALE 8:1

THIS DRAWING IS A CONTROLLED DOCUMENT.		OWN: PETER PAN 04FEB2013	 TE Connectivity
DIMENSIONS: mm		CHK: JASON YANG 04FEB2013	
TOLERANCES UNLESS OTHERWISE SPECIFIED:		APPV: ALEY CAI 04FEB2013	
0 PLC ±0.25 1 PLC ±0.25 2 PLC ±0.20 3 PLC ±0.20 4 PLC ±0.20 ANGLES ±°		NAME: OSFP IXI CAGE ASSEMBLY SOLDER, THRU BEZEL	
MATERIAL:	FINISH:	PRODUCT SPEC: 108-2286	SIZE: A100779
		APPLICATION SPEC: 114-13217	CAGE CODE: 2170322
		WEIGHT:	RESTRICTED TO:
		CUSTOMER DRAWING	SCALE: 2:1 SHEET 6 OF 6 REV D