

REVISIONS			
REV	DESCRIPTION, ECN, EAR NO.	DATE	APP'D
E	PROPOSAL	JUL18/12	L.CHAN
F	ADD CO-PLANARITY SPEC AND CORRECT SHIELD TABS	FEB 13/17	L.CHAN

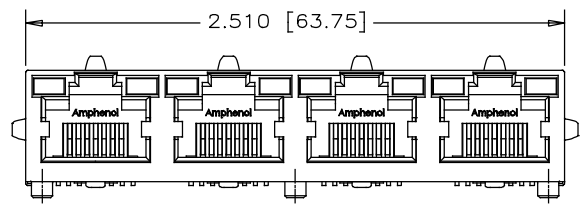

FRONT VIEW

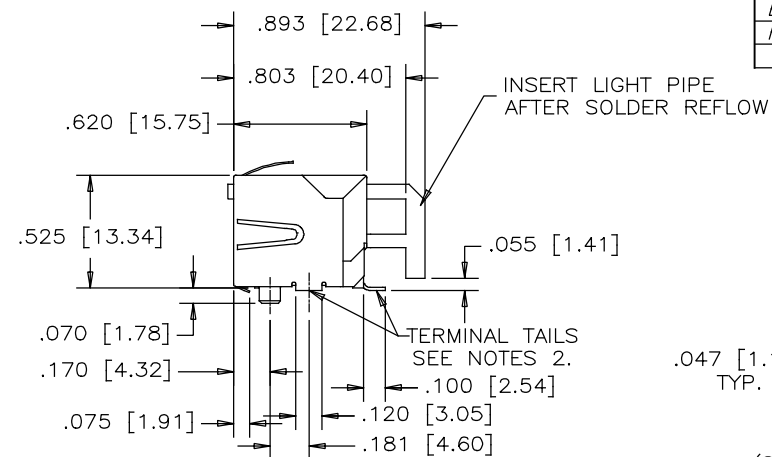

SIDE VIEW

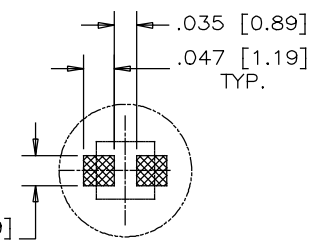

DETAIL 'A'  
(ENLARGED)

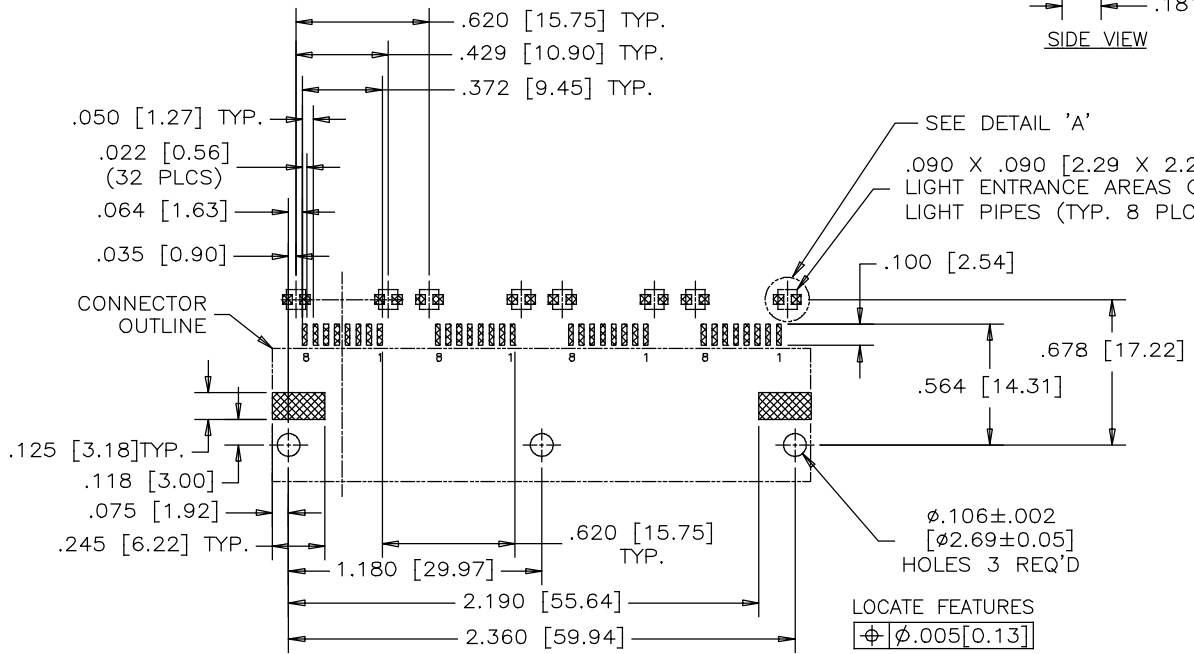

RECOMMENDED P.C.B. LAYOUT  
(COMPONENT SIDE OF BOARD)

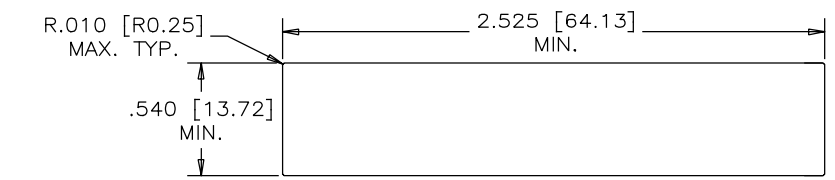

RECOMMENDED PANEL CUTOUT

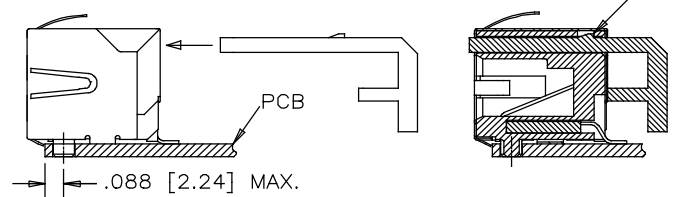

AFTER SOLDER REFLOW, LOAD LIGHT PIPE THROUGH THE CONNECTOR REAR ACCESS IN THE DIRECTION AS SHOWN

1. MATERIALS:
- PLASTIC HOUSING: HIGH TEMPERATURE THERMOPLASTIC  
FLAMMABILITY RATING UL 94V-0
  - CONTACTS: PHOSPHOR BRONZE  
PLATING: 20 μ" [0.51 MICRONS] MIN. GOLD ON MATING SURFACES.  
50 μ" [1.27 MICRONS] MIN. NICKEL UNDERPLATE.  
100 μ" [2.54 MICRONS] MIN. MATTE TIN ON CONTACT TAILS.
  - SHIELD: COPPER ALLOY  
PLATING: NICKEL
  - LIGHT PIPE: CLEAR POLYCARBONATE  
FLAMMABILITY RATING UL 94V-0

2. COPLANARITY SPECIFICATION:  
WITH THE MODULAR JACK SITTING ON A LEVEL SURFACE, THE MAXIMUM GAP BETWEEN THE LEVEL SURFACE OF SHIELD TAB AND ALL TERMINAL TAILS IS .004 [0.10].

AMPHENOL PART NUMBER: RJSE-5381-04



UNLESS SPECIFIED OTHERWISE	DRAWN Chiqow Xu	DATE DEC.25/06
PRIMARY UNITS INCH	CHECKED L.CHAN	DEC.25/06
SECONDARY MILLIMETER	M.E. APP'D	
REFERENCE IN PARENTHESES	Q.A. APP'D	
GENERAL TOLERANCES	DWG APPR.	
1 DECIMAL PLACE ±0.025	ENG. REL. NO.	
2 DECIMAL PLACES ±0.020	REF. EAR: RJ12078	
3 DECIMAL PLACES ±0.015	THIRD ANGLE PROJECTION	
ANGULAR DEGREES ±1.0°	DO NOT SCALE DRAWING	

Amphenol Canada Corp. www.amphenolcanada.com	
TITLE	4 PORT SURFACE MOUNT JACK 8 POSITION, 8 CONTACTS, SHIELD, WITH LIGHT PIPES - RoHS COMPLIANT
DWG. NO.	P-RJSE-5381-04
CODE ID NO. 03554	DWG SIZE: C SCALE: N/A SHEET 1 OF 1