

1.1 Scope.

This specification covers the requirements for 12-bit, high speed digital-to-analog converters (DACs). The AD9712B/883B is a 12-bit ECL-compatible DAC which features update rates of 100 Msps minimum; the TTL-compatible AD9713B/883B will update at 80 Msps minimum.

1.2 Part Number.

Device	Part Number	Device	Part Number
-1	AD9712BS(X)/883B	-3	AD9713BS(X)/883B
-2	AD9712BT(X)/883B	-4	AD9713BT(X)/883B

SMD Number 5962-90911 in development.

1.2.3 Case Outline.

See Appendix 1 of General Specification ADI-M-1000: package outline:

(X)	Package	Description
Q	Q-28	28-Pin Ceramic DIP
E	E-28A	28-Pin Leadless Chip Carrier

1.3 Absolute Maximum Ratings. ($T_A = +25^\circ\text{C}$ unless otherwise noted)

Positive Supply Voltage ($+V_S$)	+6 V
Positive Supply Voltage ($-V_S$)	-7 V
Analog-to-Digital Ground Voltage Differential	0.5 V
Digital Input Voltages (D_1 - D_{12} , LATCH ENABLE)		
AD9712B	0 V to $-V_S$
AD9713B	-0.5 V to $+V_S$
Internal Reference Output Current	500 μA
Control Amplifier Input Voltage Range	0 V to -4.0 V
Control Amplifier Output Current	± 2.5 mA
Reference Input Voltage (V_{REF})	-3.7 V to $-V_S$
Analog Output Current	30 mA
Operating Temperature Range (Case)		
AD9712B/AD9713BSE/SQ/TE/TQ	-55°C to +125°C
Junction Temperature	+175°C
Storage Temperature Range (Case)	-65°C to +150°C
Lead Soldering Temperature (10 sec)	+300°C

1.5 Thermal Characteristics.

Maximum junction temperature should not be allowed to exceed +175°C. Typical thermal impedances with parts soldered in place; no air flow:

- 28-pin ceramic DIP: $\theta_{JA} = 32^\circ\text{C}/\text{W}$, $\theta_{JC} = 10^\circ\text{C}/\text{W}$;
- 28-pin LCC: $\theta_{JA} = 41^\circ\text{C}/\text{W}$, $\theta_{JC} = 13^\circ\text{C}/\text{W}$.

AD9712B/AD9713B—SPECIFICATIONS

Table I.

Test	Symbol	Device	Design Limits ¹	Sub Group 1	Sub Group 2, 3	Sub Group 4	Sub Group 5, 6	Sub Group 9	Test Conditions ²	Units
Differential Nonlinearity	DNL	-1, -3 -2, -4				±1.5 ±1.0	±2.0 ±1.5			LSB
Integral Nonlinearity	INL	-1, -3 -2, -4				±1.75 ±1.25	±2.0 ±1.75			LSB
Zero-Scale Offset Error	I _{OS}	All		2.5	5.0					μA max
Full-Scale Gain Error		All		5	8.0					% max
Internal Reference Voltage	V _{IR}	All		-1.11	-1.09					V min
				-1.25	-1.27					V max
Internal Reference Output Current	I _{IR}	All	-50							μA min
			+500							μA max
Output Compliance Range	V _{OC}	All	-1.2					@ +25°C		V min
			+2					@ +25°C		V max
Output Resistance	R _O	All	2.0					@ +25°C		kΩ min
			3.0					@ +25°C		kΩ max
Output Update Rate ³		-1, -2 -3, -4	100 80					@ +25°C		Msp/s min
Digital Logic "1" Input Voltage	V _{IH}	-1, -2 -3, -4		-1.0 2.0	-1.0 2.0					V min
Digital Logic "0" Input Voltage	V _{IL}	-1, -2 -3, -4		-1.5 0.8	-1.5 0.8					V max
Digital Logic "1" Input Current	I _{IH}	All		20	20					μA max
Digital Logic "0" Input Current	V _{IL}	-1, -2 -3, -4		10 600	10 600					μA max
Input Setup Time ⁴	t _S	All	-0.8							ns min
Input Hold Time ⁵	t _H	All	2.0							ns min
Latch Pulse Width (LOW) (transparent)	t _{LPW}	All	2.8							ns min
+V _S Supply Current	+I _S	-3, -4		12	14					mA max
-V _S Supply Current	-I _S	-1, -2 -3, -4		178 184	183 188					mA max
Power Supply Rejection Ratio ⁶	PSRR	All				125		@ +25°C		μA/V max

NOTES

¹Value shown is over full temperature range unless otherwise noted in Test Condition. Number in this column indicates specification is guaranteed but not tested.

²+V_S = +5 V; -V_S = -5.2 V; reference voltage = -1.2 V; R_{SET} = 7.5 kΩ; V_{OUT} = 0 V (virtual ground), unless otherwise indicated.

³Data registered into DAC accurately at this rate; does not imply settling to 12-bit accuracy.

⁴Data must remain stable for specified time prior to falling edge of LATCH ENABLE signal.

⁵Data must remain stable for specified time after rising edge of LATCH ENABLE signal.

⁶Measured at ±5% of +V_S (AD9713B only) and -V_S (AD9712B or AD9713B) using external reference.

Specifications subject to change without notice.

3.2.1 Functional Block Diagram and Terminal Assignments.

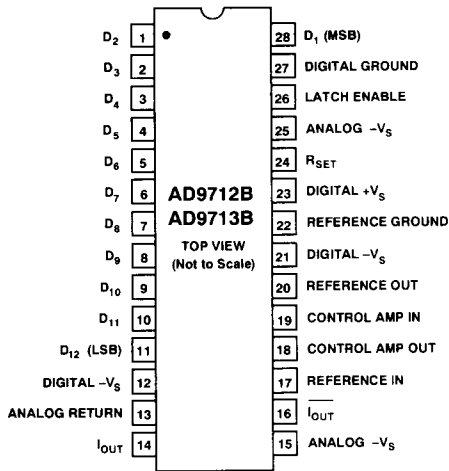
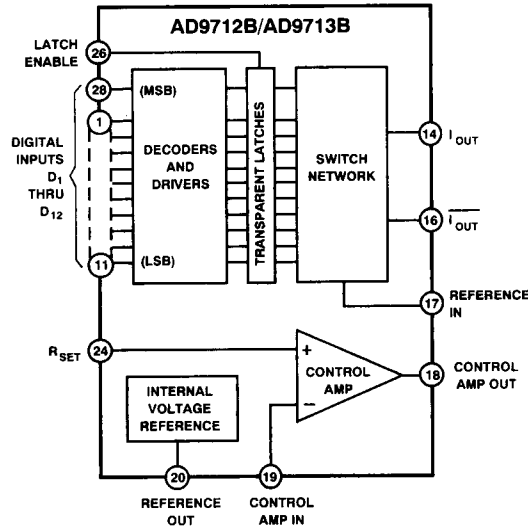

DIP Pinout Designations

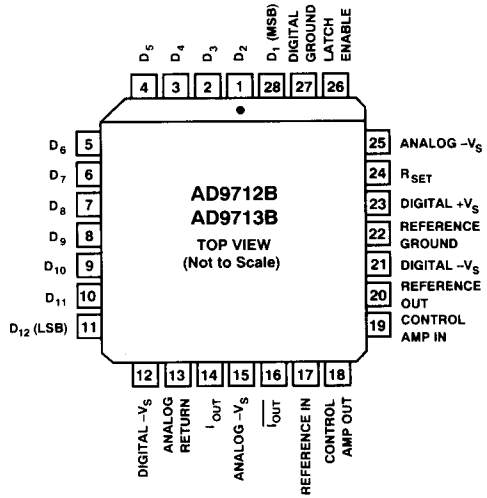

Ceramic LCC Pinout Designations

