

Evaluation Board for CS5346

Features

- ◆ Single-ended Analog Inputs
- ◆ Single-ended Analog Outputs
- ◆ CS8406 S/PDIF Digital Audio Transmitter
- ◆ Header for Optional External Software Configuration of CS5346
- ◆ Header for External PCM Serial Audio I/O
- ◆ 3.3 V Logic Interface
- ◆ Pre-defined Software Scripts
- ◆ Demonstrates Recommended Layout and Grounding Arrangements
- ◆ Windows®-compatible Software Interface to Configure CS5346 and Inter-board Connections

Description

The CDB5346 evaluation board is an excellent means for evaluating the CS5346 ADC. Evaluation requires an analog signal source and analog/digital analyzer, and power supplies. A Windows PC-compatible computer must be used to evaluate the CS5346.

System timing for the I²S, Left-Justified and Right-Justified interface formats can be provided by the CS5346, the CS8406, or by the PCM I/O stake header with an external source connected.

RCA phono jacks are provided for the CS5346 analog inputs and outputs. Digital data input is available via RCA phono or optical connectors to the CS8406.

The Windows software provides a GUI to make configuration of the CDB5346 easy. The software communicates through the PC's USB to configure the control port registers so that all features of the CS5346 can be evaluated. The evaluation board may also be configured to accept external timing and data signals for operation in a user application during system development.

ORDERING INFORMATION

CDB5346

Evaluation Board

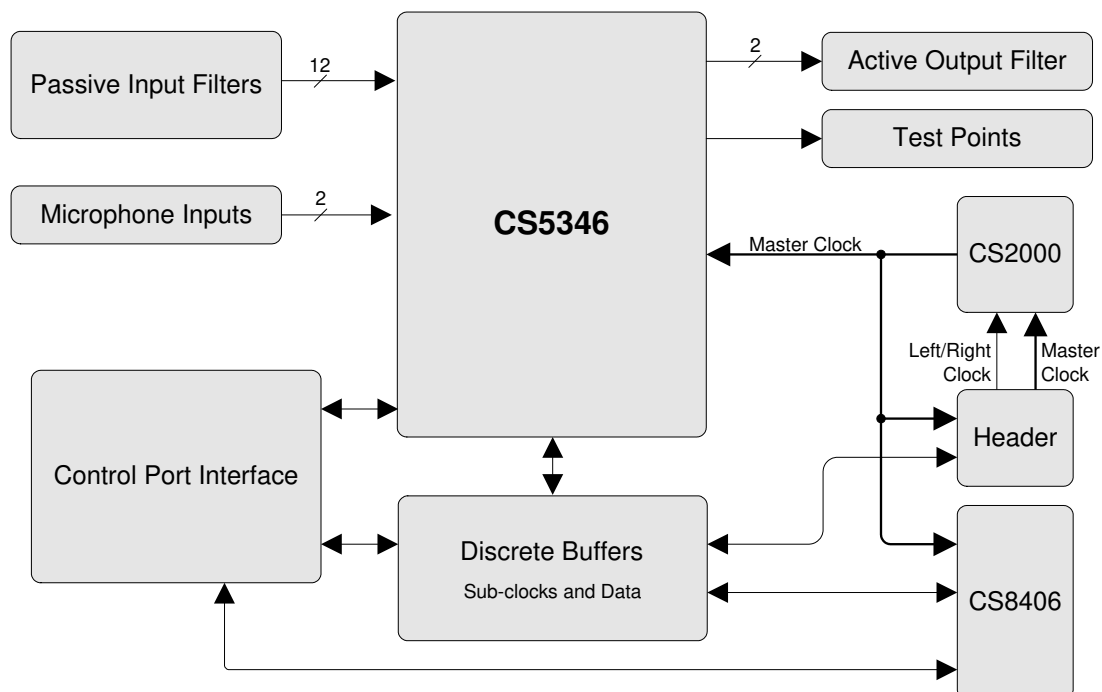

TABLE OF CONTENTS

1. SYSTEM OVERVIEW	3
1.1 Power	3
1.2 Grounding and Power Supply Decoupling	3
1.3 CS5346 Audio ADC	3
1.4 CS8406 Digital Audio Transmitter	3
1.5 CS2000	4
1.6 External Control Headers	4
1.7 Analog Inputs	4
1.8 Analog Outputs	4
1.9 Serial Control Port	4
2. SYSTEM CLOCKS AND DATA	5
2.1 Clock Routing	5
2.2 Data Routing	5
3. PC SOFTWARE CONTROL	6
3.1 CDB5346 Controls Tab	6
3.2 Register Maps Tab	7
3.3 Pre-Configured Script Files	7
3.3.1 12.288MHz, CS5346 Master - ADC Ch 1 In to SPDIF Out	7
3.3.2 12.288MHz, CS8406 Master - ADC Ch 1 In to SPDIF Out	8
3.3.3 12.288MHz, J10 Master - ADC Ch 1 In to SPDIF Out	8
4. CDB CONNECTORS, JUMPERS, AND SWITCHES	9
5. CDB BLOCK DIAGRAM	10
6. CDB SCHEMATICS	11
7. CDB LAYOUT	16
8. REVISION HISTORY	19

LIST OF FIGURES

Figure 1.CDB5346 Controls Tab	6
Figure 2.Register Maps Tab	7
Figure 3.Block Diagram	10
Figure 4.CS5346 (Schematic Sheet 1)	11
Figure 5.Analog Inputs/Outputs (Schematic Sheet 2)	12
Figure 6.USB Microcontroller (Schematic Sheet 3)	13
Figure 7.S/PDIF and PCM Output (Schematic Sheet 4)	14
Figure 8.Power (Schematic Sheet 5)	15
Figure 9.Component Map	16
Figure 10.Top Layer	17
Figure 11.Bottom Layer	18

LIST OF TABLES

Table 1. System Connections	9
Table 2. System Jumper Settings	9
Table 3. Revision History	19

1. SYSTEM OVERVIEW

The CDB5346 evaluation board is an excellent means for evaluating the CS5346 ADC. Analog and digital audio signal interfaces are provided, a simple bus architecture is used for easily configuring the evaluation platform, and a USB cable is included for use with the Windows® configuration software available for download from www.cirrus.com.

The CDB5346 schematic set is shown in Figures 4 through 8. Though the CS5346 device is compatible with the CS5345 device the CDB5346 platform was not designed to accommodate the CS5345. For CS5345 comparisons please use the CDB5345.

1.1 Power

Power must be supplied to the evaluation board through the red +5.0 V binding post. An on-board regulator provides 3.3 V. Appropriate supply levels for powering VA, VD, VLS, and VLC are set by a series of jumpers (see Table 2 on page 9). All voltage inputs must be referenced to the single black binding post ground connector (see Table 1 on page 9).

WARNING: Please refer to the CS5346 data sheet for allowable voltage levels.

1.2 Grounding and Power Supply Decoupling

The CS5346 requires careful attention to power supply and grounding arrangements to optimize performance. Figure 3 on page 10 provides an overview of the connections to the CS5346. Figure 9 on page 16 shows the component placement. Figure 10 on page 17 shows the top layout. Figure 11 on page 18 shows the bottom layout. The decoupling capacitors are located as close to the CS5346 as possible. Attention has been paid to maximize the ground plane fill on the evaluation board. The series resistors on the analog inputs have been placed close to the CS5346 device in order to reduce any unwanted coupling from long traces with high source impedance.

1.3 CS5346 Audio ADC

A complete description of the CS5346 is included in the CS5346 product data sheet.

The required configuration settings of the CS5346 are made in its control port registers, accessible through the CS5346 tab of the Cirrus Logic FlexGUI software.

Clock and data source selections are made through the microcontroller. Basic routing selections can be made using the CS5346 Controls tab in the GUI software application. Advanced options are accessible through the Board Configuration sub-tab on the Register Maps tab of the Cirrus Logic FlexGUI software.

1.4 CS8406 Digital Audio Transmitter

A complete description of the CS8406 transmitter (Figure 7 on page 14) and a discussion of the digital audio interface are included in the CS8406 data sheet.

The CS8406 converts the PCM data generated by the CS5346 to the standard S/PDIF data stream. The CS8406 can operate in either master or slave mode, accepts 128 Fs, 256 Fs, 384 Fs, and 512 Fs master clocks on the OMCK input pin, and can operate in the Left-Justified, I²S, Right-Justified 16-bit, and Right-Justified 24-bit interface formats.

The most common operations of the CS8406 may be controlled via the CDB5346 Controls tab in the GUI software application. Advanced options are accessible through the CS8406 sub-tab on the Register Maps tab of the Cirrus Logic FlexGUI software.

1.5 CS2000

The CS2000-CP, U7, provides the master clock source to the CDB5346.

The CS2000-CP is a highly configurable clock synthesizer and jitter reducing clock multiplier. Simple scripts have been pre-configured to generate the necessary configuration settings for the CS2000-CP. For a more in depth look at this device please see the CS2000-CP data sheet.

1.6 External Control Headers

The evaluation board has been designed to allow interfacing with external systems via the headers J19, and J21.

The 8-pin, 2 row header, J21, provides access to the serial audio signals required to interface to the serial audio port of the CS5346 with a DSP (see [Figure 7 on page 14](#)).

The direction of the signals on header J21 can be configured using the controls located within the Board Controls group box on the CDB5346 Controls tab in the provided GUI software.

The 15-pin, 3 row header, J19, allows the user bidirectional access to the SPI/I²C control signals by simply removing all the shunt jumpers from the “PC” position. The user may then choose to connect a ribbon cable to the “EXTERNAL CONTROL” position. A single “GND” row for the ribbon cable’s ground connection is provided to maintain signal integrity. Two unpopulated pull-up resistors are also available should the user choose to use the CDB for the I²C power rail.

1.7 Analog Inputs

RCA connectors supply the CS5346 analog inputs through single-ended, unity gain, passive circuits. Refer to the CS5346 data sheet for the ADC full-scale input level and input impedance.

1.8 Analog Outputs

The CS5346 PGA analog outputs are routed through a source-follower op-amp to provide a low impedance drive and to observe the current draw limitations of the PGA output pins. The output of the amp is connected to RCA jacks for easy evaluation.

1.9 Serial Control Port

A graphical user interface is included with the CDB5346 to allow easy manipulation of the registers in the CS5346, CS8406, and CS2000-CP. See the device-specific data sheets for the CS5346, CD8406, and CS2000-CP internal register descriptions.

Connecting a USB cable to connector J17 and launching the Cirrus Logic FlexGUI software (FlexLoader.exe) will enable the CDB5346.

Refer to [“PC Software Control” on page 6](#) for a description of the Graphical User Interface (GUI).

2. SYSTEM CLOCKS AND DATA

The CDB5346 implements comprehensive clock routing capabilities. Configuration of the clock routing can be easily achieved using the controls within the Board Controls group box on the CDB5346 Controls tab in the GUI software application.

2.1 Clock Routing

The master clock signal (MCLK) is always sourced from the CS2000-CP (U18). The CS2000-CP can be configured to either synthesize a clock from the crystal (Y1) or to be phase locked looped to either the MCLK or LRCK input from the PCM I/O header (J21).

The sub-clock signals (SCLK and LRCK) may be sourced from the CS5346 in master mode, the CS8406 in master mode, or the PCM I/O header.

Clock routing configuration is achieved using the controls within the Board Controls group box on the CDB5346 Controls tab in the GUI software application.

2.2 Data Routing

The serial data output of the CS5346 is routed to both the CS8406 S/PDIF transmitter and the PCM I/O header. No user configuration of the serial data routing is required.

3. PC SOFTWARE CONTROL

The CDB5346 uses a Microsoft Windows-based GUI (download from Cirrus web site), which allows control of the CS5346, CS8416, CS8406 and CS2000-CP registers. Interface to the GUI is provided via USB connection. Once the USB cable is connected between the CDB5346 and the host PC, run “FlexLoader.exe”. The software should automatically detect the board. If a board selection dialog is displayed, select “CDB5346” from the list. Once loaded, all registers are set to their default state. The GUI’s “File” menu provides the ability to save and load script files containing all of the register settings. Sample script files for basic mode operation can be downloaded from the archive at www.cirrus.com. Refer to “Pre-Configured Script Files” on page 7 for details.

3.1 CDB5346 Controls Tab

The CDB5346 Controls tab provides a high-level intuitive interface to many of the configuration options of the CS5346 and CDB5346. The controls within the CS5346 Controls group box control the internal registers of the CS5346 (with the exception of AD0/AD1 which are controlled by GPIO on the on-board microcontroller). The controls within the Board Controls group box control the board level clock and data routing on the CDB5346.

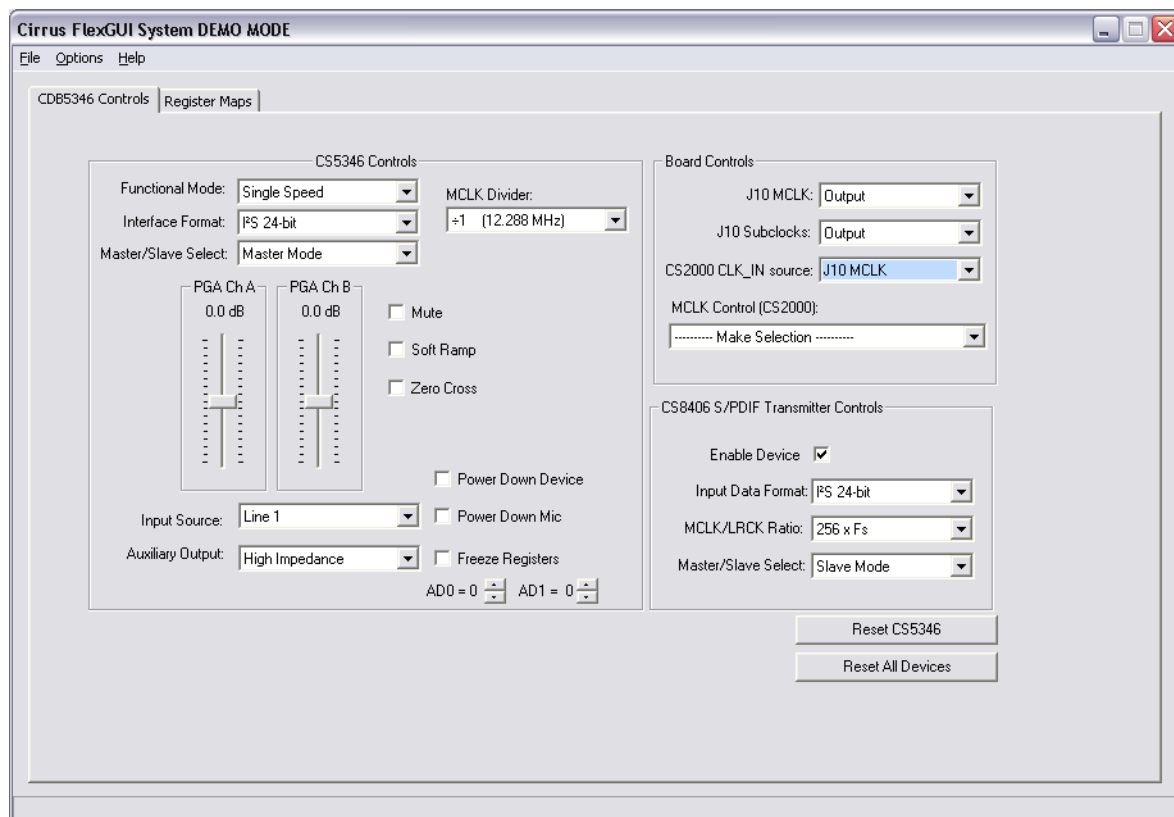

Figure 1. CDB5346 Controls Tab

3.2 Register Maps Tab

The Register Maps tab provides low level control over the register level settings of the CS5346, CS8406, and CS2000-CP. Each device is displayed on a separate tab. Register values can be modified bit-wise or byte-wise. For bit-wise, click the appropriate push button for the desired bit. For byte-wise, the desired hex value can be typed directly in the register address box in the register map.

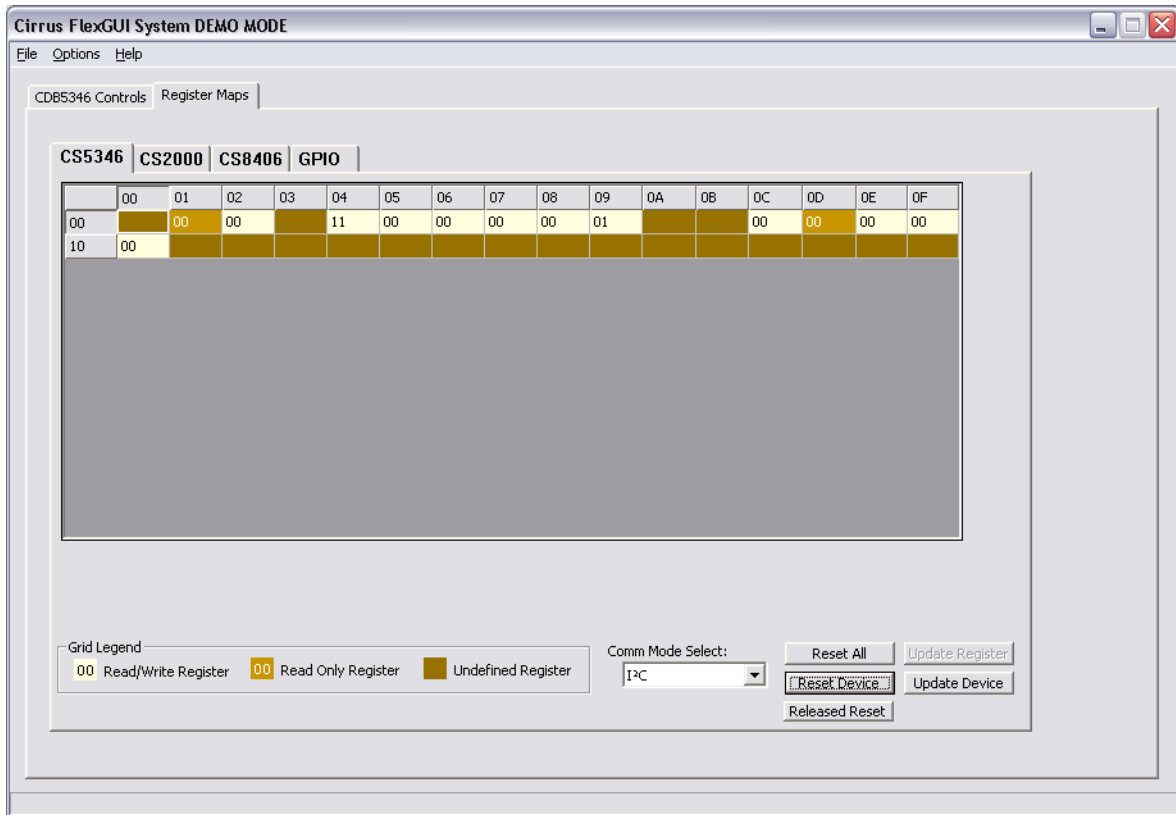

Figure 2. Register Maps Tab

3.3 Pre-Configured Script Files

Pre-configured script files are provided with the CDB5346 to allow easy initial board bring-up. The board configurations stored within these files are described in sections 3.3.1 - 3.3.2.

3.3.1 12.288MHz, CS5346 Master - ADC Ch 1 In to SPDIF Out

Using the pre-configured script file named “12.288MHz _CS5346 Master_- ADC Ch 1 In to SPDIF Out.fgs”, an analog input signal applied to channel 1 of the CS5346 input multiplexer will be digitized by the ADC in Master Mode, transmitted in S/PDIF format by the CS8406. No signal will be output through the active output filter and RCA jacks.

The CS2000-CP is operated in frequency synthesizer mode to generate the 12.288 MHz master clock. The CS5346 is the sub-clock master to the CS8406 and the PCM I/O header.

3.3.2 12.288MHz, CS8406 Master - ADC Ch 1 In to SPDIF Out

Using the pre-configured script file named “12.288MHz _CS8406 Master_- ADC Ch 1 In to SPDIF Out.fgs”, an analog input signal applied to channel 1 of the CS5346 input multiplexer will be digitized by the ADC and transmitted in S/PDIF format by the CS8406 in Master Mode. No signal will be output through the active output filter and RCA jacks.

The CS2000-CP is operated in frequency synthesizer mode to generate the 12.288 MHz master clock. The CS8406 is the sub-clock master to the CS5346 and the PCM I/O header.

3.3.3 12.288MHz, J10 Master - ADC Ch 1 In to SPDIF Out

Using the pre-configured script file named “12.288MHz _J10 Master_- ADC Ch 1 In to SPDIF Out.fgs”, an analog input signal applied to channel 1 of the CS5346 input multiplexer will be digitized by the ADC and transmitted in S/PDIF format by the CS8406. No signal will be output through the active output filter and RCA jacks.

The CS2000-CP is operated in frequency synthesizer mode to generate the 12.288 MHz master clock. The PCM I/O header is the sub-clock master to the CS5346 and the CS8406.

4. CDB CONNECTORS, JUMPERS, AND SWITCHES

CONNECTOR	Reference Designator	INPUT/OUTPUT	SIGNAL PRESENT
+5V	J22	Input	+5.0 V Power Supply
GND	J24	Input	Ground Reference
S/PDIF TX	J20	Output	CS8406 digital audio output via coaxial cable
S/PDIF TX	OPT1	Output	CS8406 digital audio output via optical cable
USB I/O	J17	Input/Output	USB connection to PC for SPI / I ² C control port signals.
PCM I/O	J21	Input/Output	I/O for Serial Audio Clocks & Data
PC / EXTERNAL CONTROL	J19	Input/Output	I/O for external SPI / I ² C control port signals.
C2	J18	Input/Output	I/O for programming the micro controller (U6).
MICRO RESET	S1	Input	Reset for the micro controller (U6).
AIN1A AIN1B AIN2A AIN2B AIN3A AIN3B AIN4A AIN4B AIN5A AIN5B AIN6A AIN6B	J1 J2 J3 J4 J5 J6 J7 J8 J9 J10 J11 J12	Input	RCA phono jacks for analog input signal to CS5346. Passive input filter.
MICIN1 MICIN2	J13 J14	Input	1/8" TRS jacks for microphone input.
PGA_OUTA PGA_OUTB	J15 J16	Output	RCA phono jacks for PGA analog outputs. Active output buffer.

Table 1. System Connections

JUMPER	PURPOSE	POSITION	FUNCTION SELECTED
J27	Selects the source of voltage for the VLC supply.	+3.3 V VA*	Voltage source is +3.3 V regulator. Voltage source is VA.
J25	Disconnect for the VD supply\	+3.3 V*	Voltage source is +3.3 V regulator.
J26	Selects the source of voltage for the VLS supply.	+3.3 V VA*	Voltage source is +3.3 V regulator. Voltage source is VA
J23	Selects the source of voltage for the VA supply	POST* USB	Voltage source is +5 V Post Voltage source is USB bus power.

*Default factory settings

Table 2. System Jumper Settings

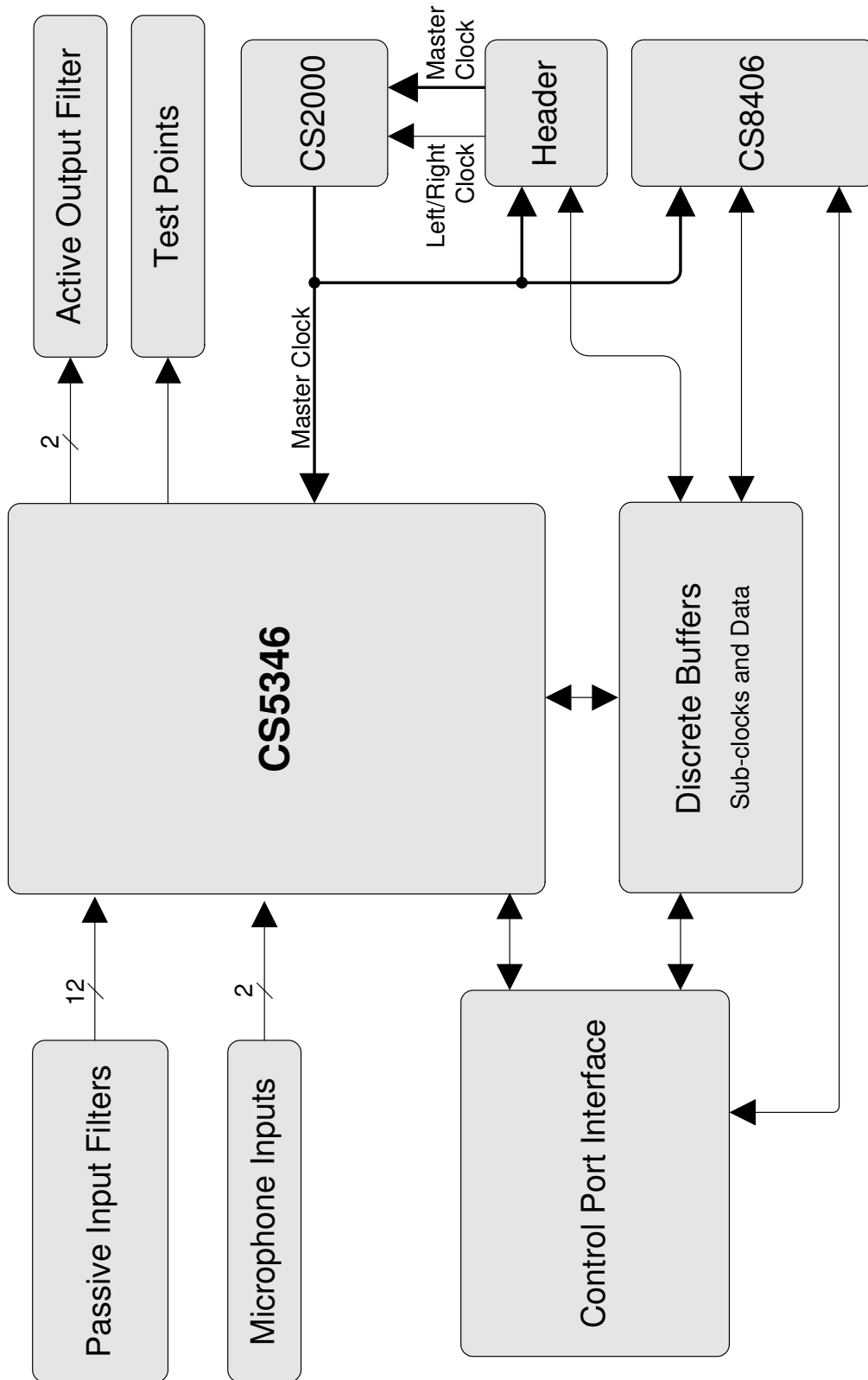
5. CDB BLOCK DIAGRAM

Figure 3. Block Diagram

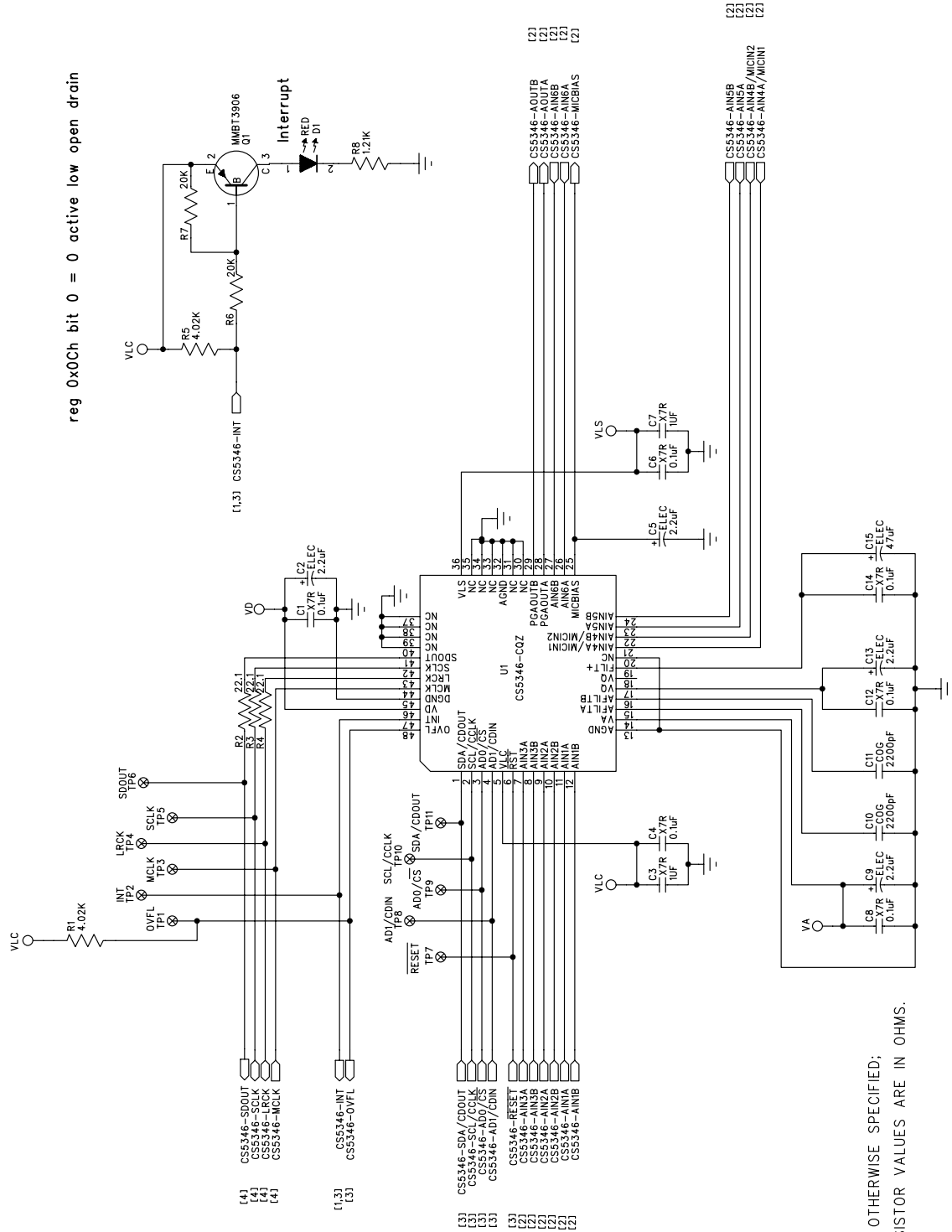
6. CDB SCHEMATICS



NOTES: UNLESS OTHERWISE SPECIFIED;
 1. ALL RESISTOR VALUES ARE IN OHMS.

Figure 4. CS5346 (Schematic Sheet 1)

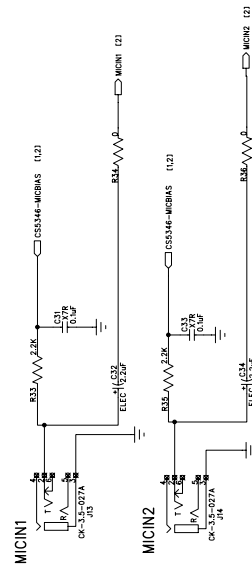
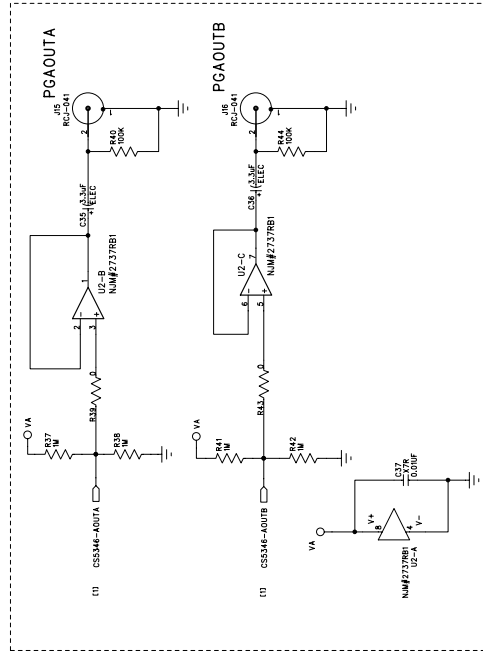
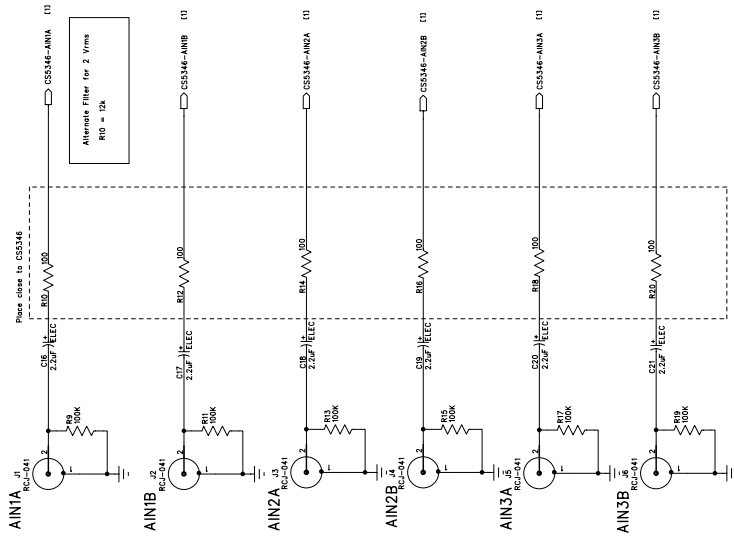
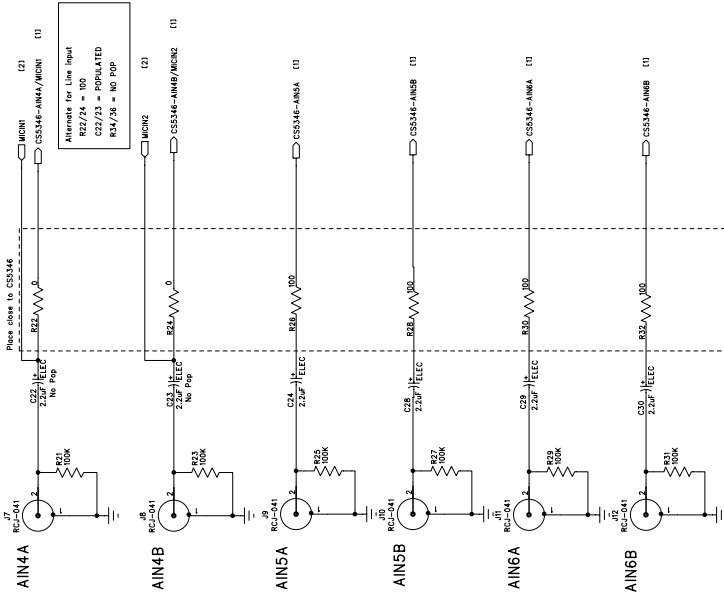

Figure 5. Analog Inputs/Outputs (Schematic Sheet 2)

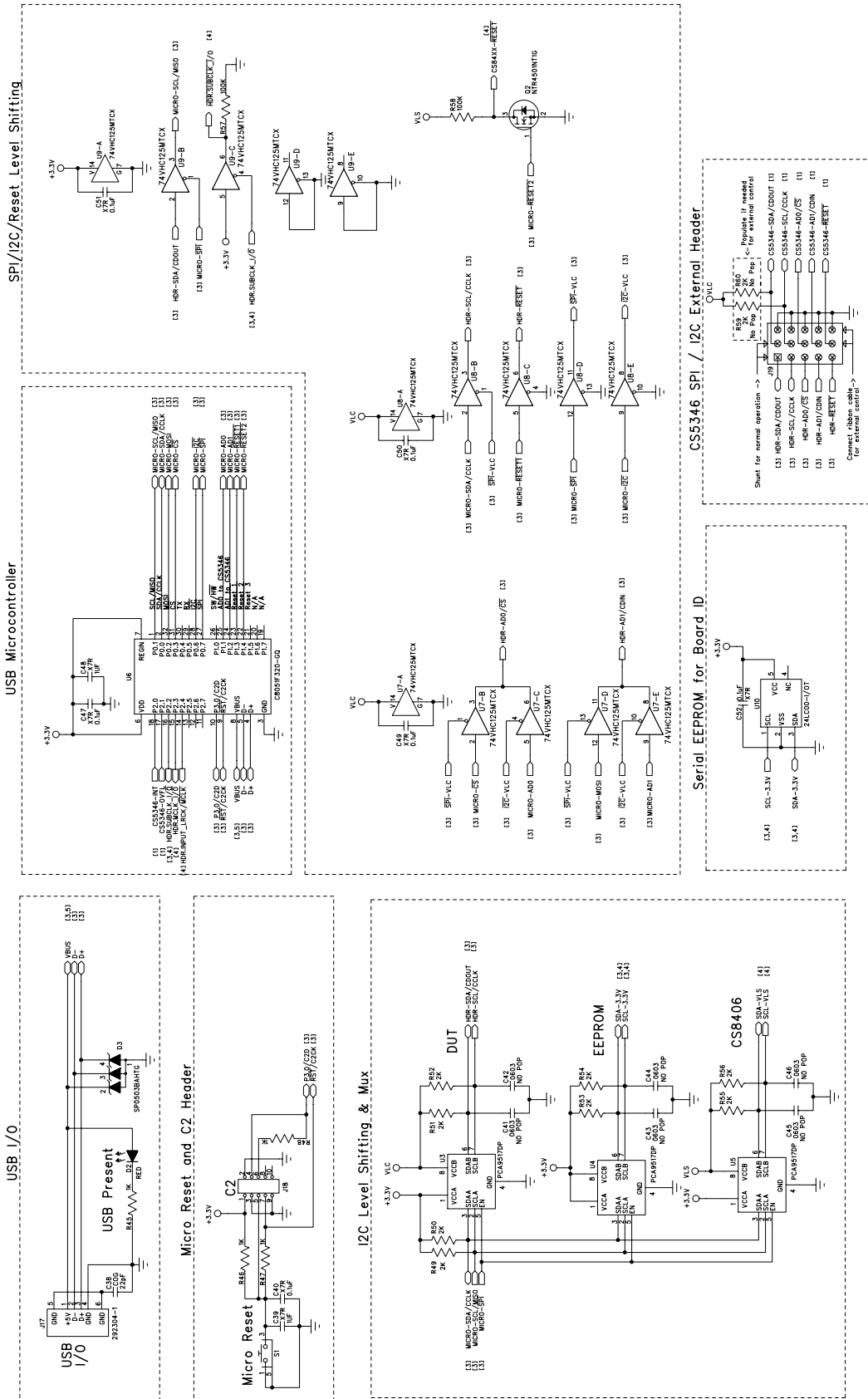
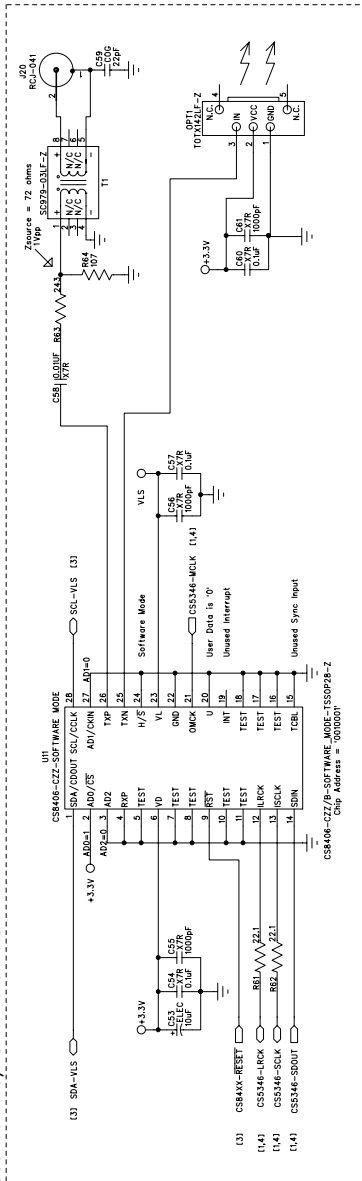
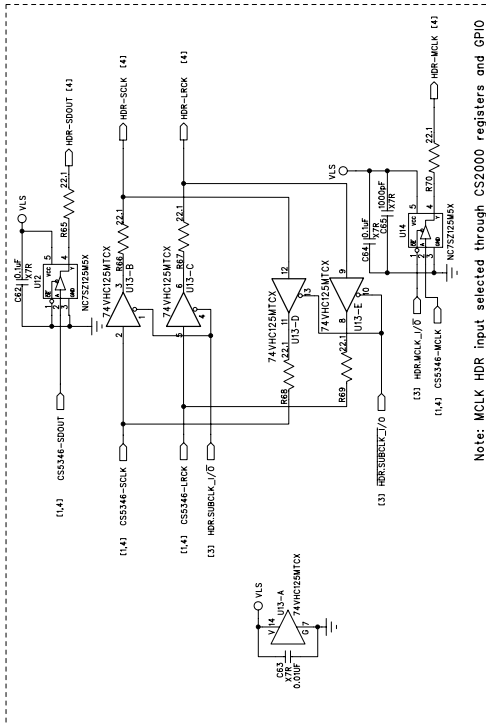

Figure 6. USB Microcontroller (Schematic Sheet 3)

CS8406 -- S/PDIF Transmitter



Header M/S and buffers interface



CS2000 MCLK interface

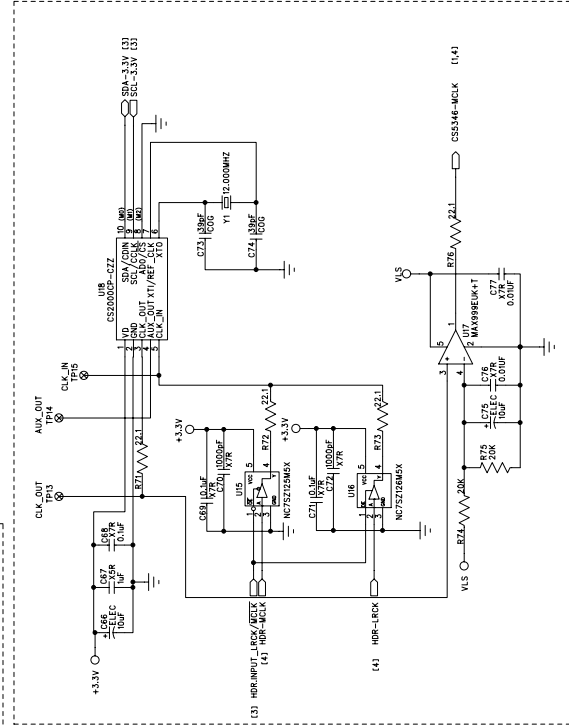

I/O Header -- VLS

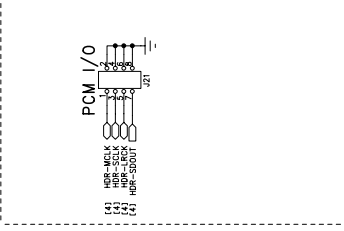

Note: MCLK HDR input selected through CS2000 registers and GPIO

Figure 7. S/PDIF and PCM Output (Schematic Sheet 4)

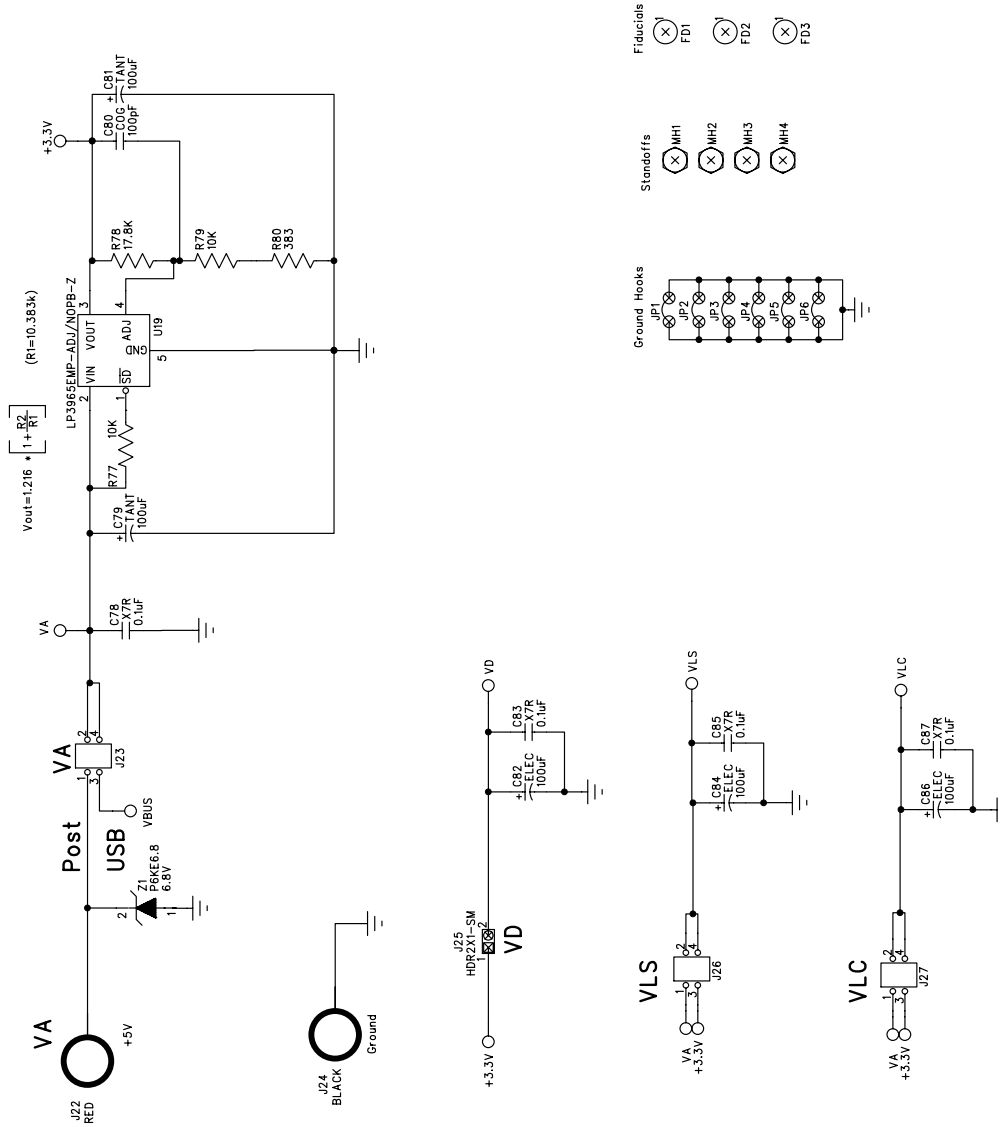

Figure 8. Power (Schematic Sheet 5)

7. CDB LAYOUT

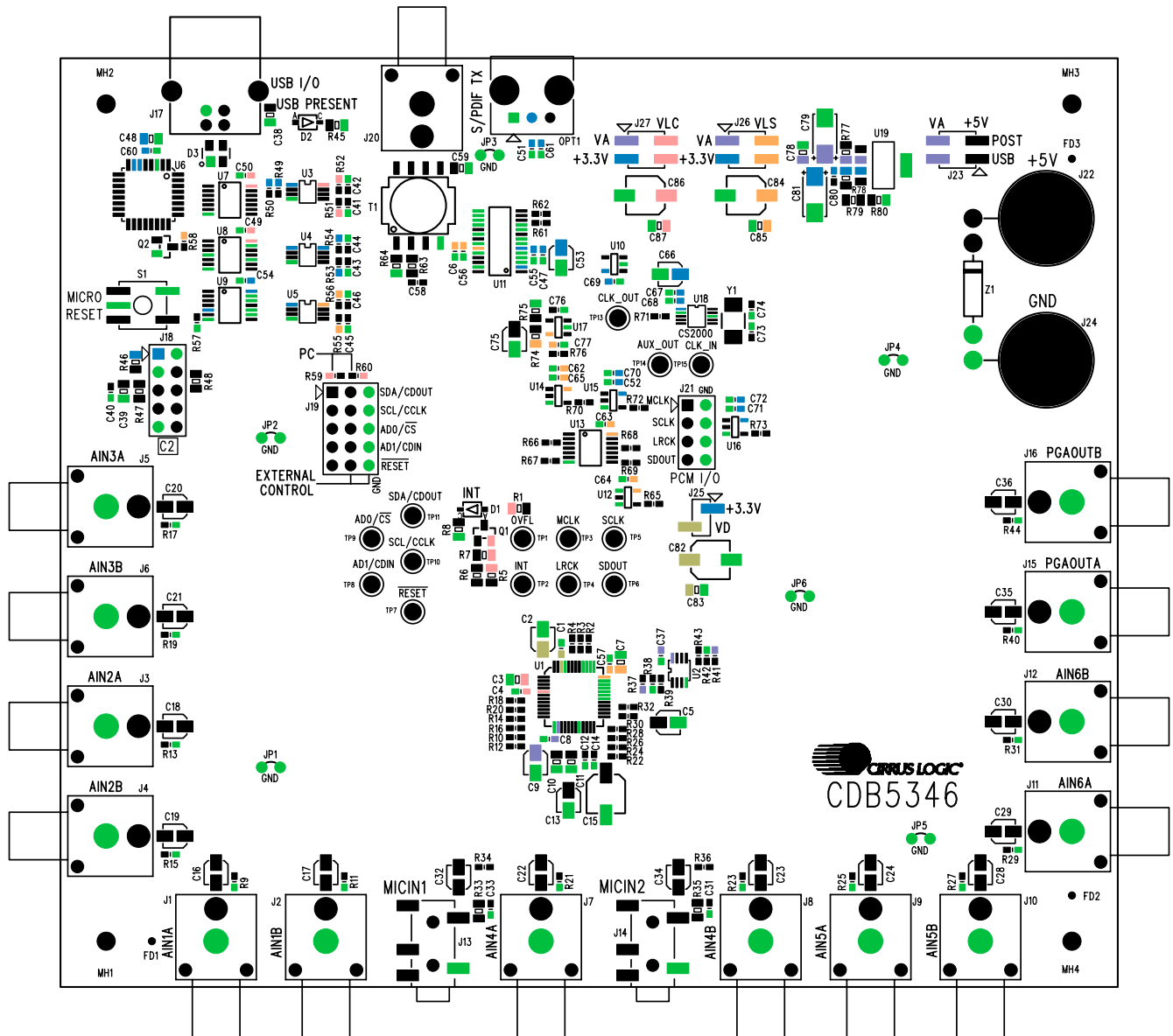

Figure 9. Component Map

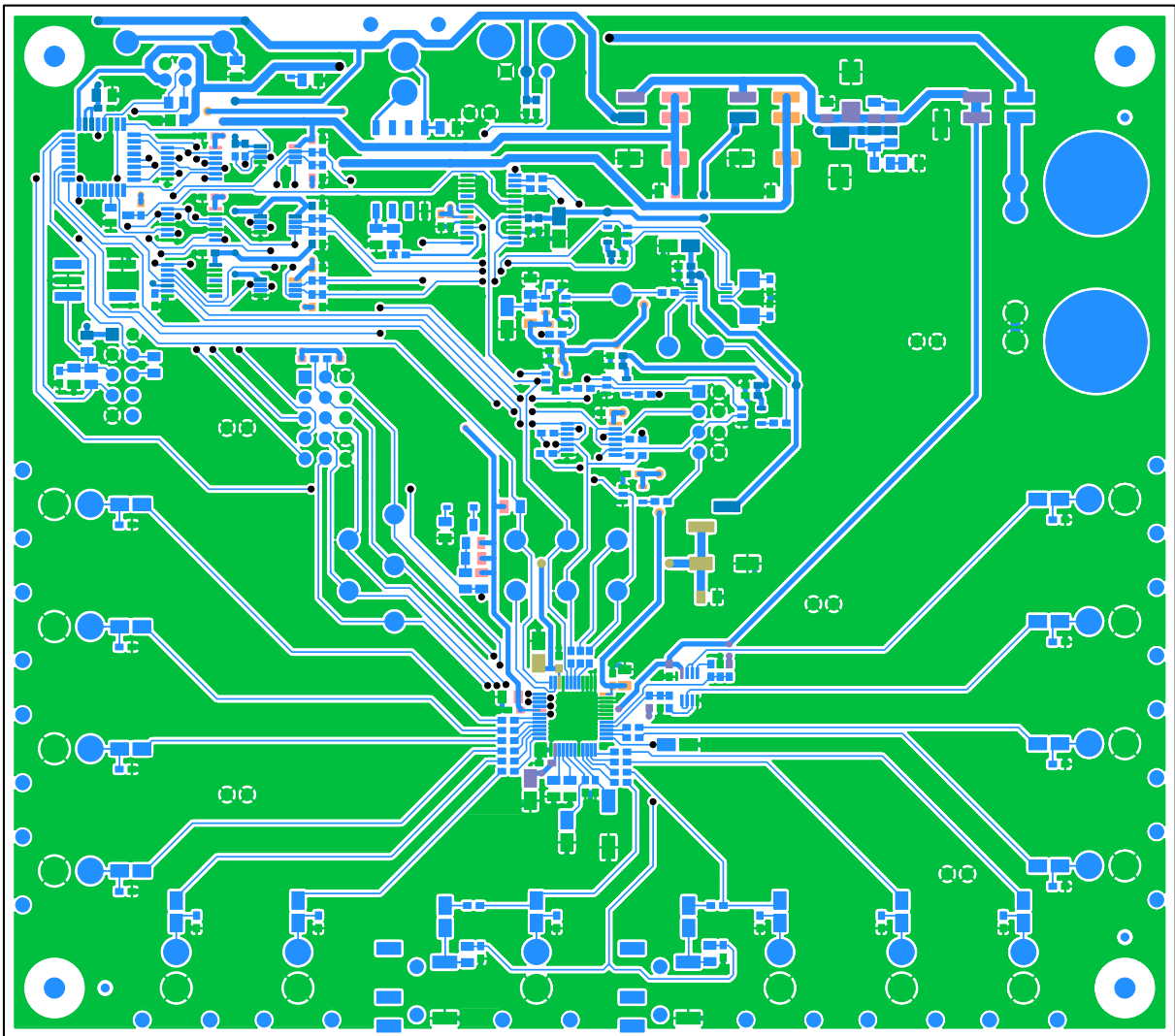

Figure 10. Top Layer

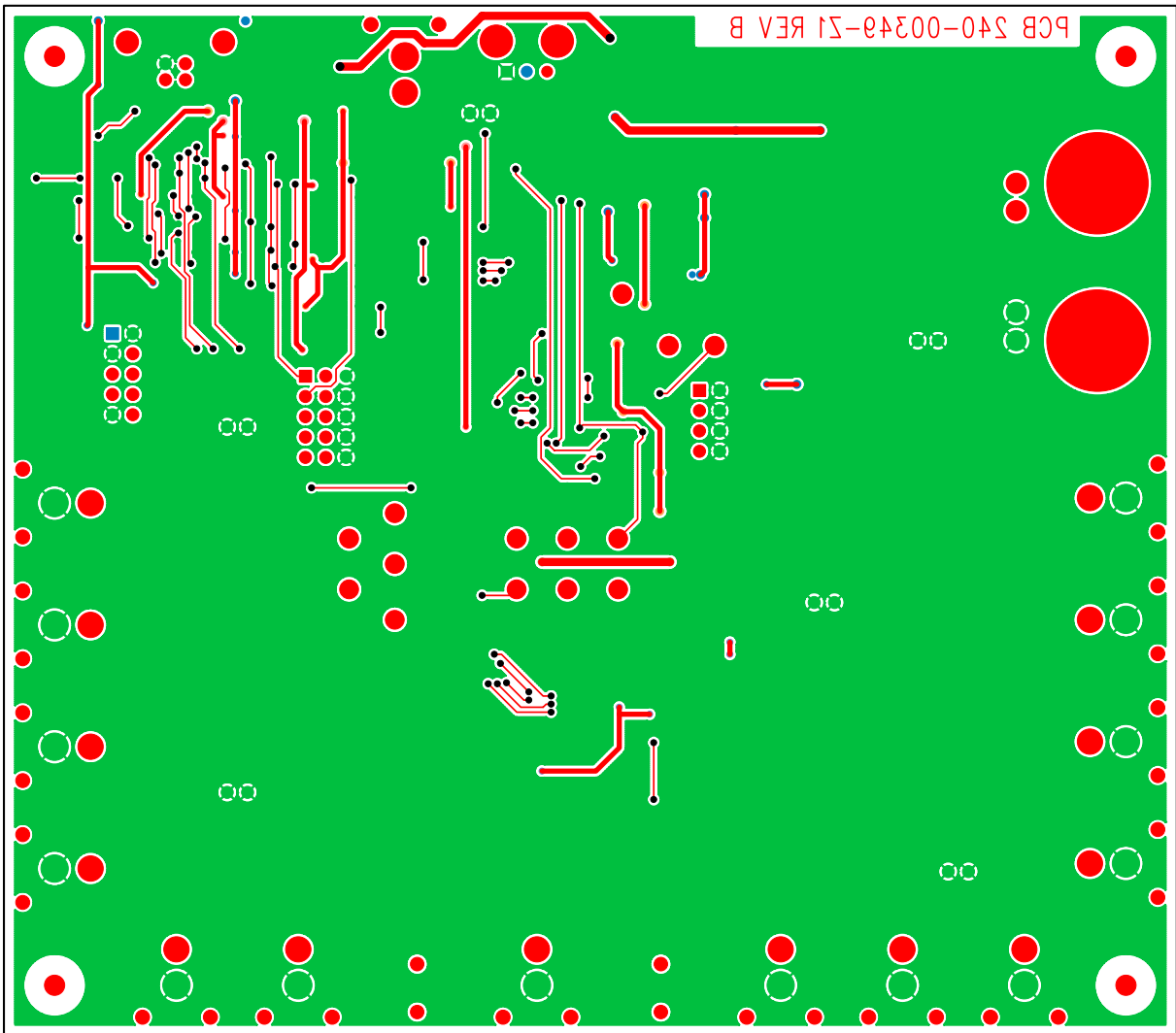

Figure 11. Bottom Layer

8. REVISION HISTORY

Revision	Changes
DB1	Initial Release

Table 3. Revision History

Contacting Cirrus Logic Support

For all product questions and inquiries, contact a Cirrus Logic Sales Representative.

To find the one nearest to you, go to www.cirrus.com.

IMPORTANT NOTICE

Cirrus Logic, Inc. and its subsidiaries ("Cirrus") believe that the information contained in this document is accurate and reliable. However, the information is subject to change without notice and is provided "AS IS" without warranty of any kind (express or implied). Customers are advised to obtain the latest version of relevant information to verify, before placing orders, that information being relied on is current and complete. All products are sold subject to the terms and conditions of sale supplied at the time of order acknowledgment, including those pertaining to warranty, indemnification, and limitation of liability. No responsibility is assumed by Cirrus for the use of this information, including use of this information as the basis for manufacture or sale of any items, or for infringement of patents or other rights of third parties. This document is the property of Cirrus and by furnishing this information, Cirrus grants no license, express or implied under any patents, mask work rights, copyrights, trademarks, trade secrets or other intellectual property rights. Cirrus owns the copyrights associated with the information contained herein and gives consent for copies to be made of the information only for use within your organization with respect to Cirrus integrated circuits or other products of Cirrus. This consent does not extend to other copying such as copying for general distribution, advertising or promotional purposes, or for creating any work for resale.

CERTAIN APPLICATIONS USING SEMICONDUCTOR PRODUCTS MAY INVOLVE POTENTIAL RISKS OF DEATH, PERSONAL INJURY, OR SEVERE PROPERTY OR ENVIRONMENTAL DAMAGE ("CRITICAL APPLICATIONS"). CIRRUS PRODUCTS ARE NOT DESIGNED, AUTHORIZED OR WARRANTED FOR USE IN PRODUCTS SURGICALLY IMPLANTED INTO THE BODY, AUTOMOTIVE SAFETY OR SECURITY DEVICES, LIFE SUPPORT PRODUCTS OR OTHER CRITICAL APPLICATIONS. INCLUSION OF CIRRUS PRODUCTS IN SUCH APPLICATIONS IS UNDERSTOOD TO BE FULLY AT THE CUSTOMER'S RISK AND CIRRUS DISCLAIMS AND MAKES NO WARRANTY, EXPRESS, STATUTORY OR IMPLIED, INCLUDING THE IMPLIED WARRANTIES OF MERCHANTABILITY AND FITNESS FOR PARTICULAR PURPOSE, WITH REGARD TO ANY CIRRUS PRODUCT THAT IS USED IN SUCH A MANNER. IF THE CUSTOMER OR CUSTOMER'S CUSTOMER USES OR PERMITS THE USE OF CIRRUS PRODUCTS IN CRITICAL APPLICATIONS, CUSTOMER AGREES, BY SUCH USE, TO FULLY INDEMNIFY CIRRUS, ITS OFFICERS, DIRECTORS, EMPLOYEES, DISTRIBUTORS AND OTHER AGENTS FROM ANY AND ALL LIABILITY, INCLUDING ATTORNEYS' FEES AND COSTS, THAT MAY RESULT FROM OR ARISE IN CONNECTION WITH THESE USES.

Cirrus Logic, Cirrus, and the Cirrus Logic logo designs are trademarks of Cirrus Logic, Inc. All other brand and product names in this document may be trademarks or service marks of their respective owners.

®C is a registered trademark of Philips Semiconductor.

Microsoft and Windows are registered trademarks of Microsoft Corporation.

SPI is a trademark of Motorola, Inc.