

Features

- Output Current up to 1A
- Output Voltages of 5, 6, 8, 9, 12, 15, 18, 24V
- Thermal Overload Protection Short Circuit Protection
- Output Transistor Safe Operating area (SOA)Protection

Description

The 78MXX three-terminal positive regulators are available in the TO-252 package with several fixed output voltages making it useful in a wide range of applications.

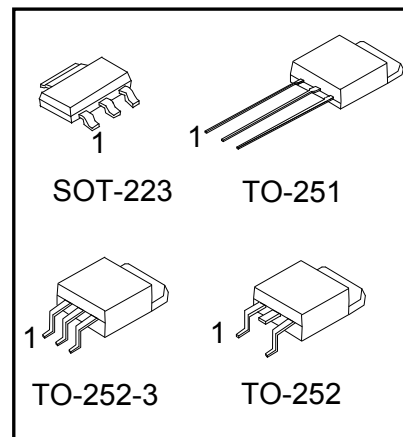

Internal Block Diagram

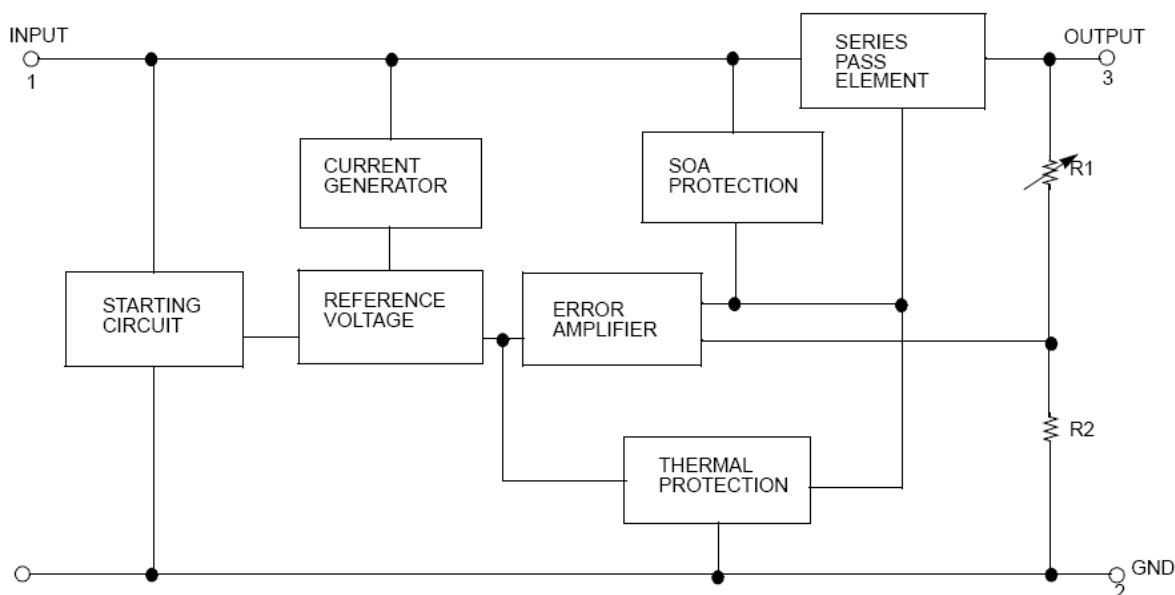

Absolute Maximum Ratings

PARAMETER	SYMBOL	RATINGS	UNIT
Input Voltage	V_{IN}	35	V
Output Current	I_{OUT}	1	A
Power Dissipation ($T_C=25^{\circ}C$)	SOT-223	1	W
	TO-251/TO-252	2	
	TO-252-3		
Operating Junction Temperature	T_J	-20 ~ 85	$^{\circ}C$
Storage Temperature	T_{STG}	-55 ~ +150	$^{\circ}C$

Thermal Data

PARAMETER		SYMBOL	RATINGS	UNIT
Junction to Case	SOT-223	θ_{JC}	15	°C/W
	TO-251/TO-252		12.5	
	TO-252-3			

Electrical Characteristics (78M05)

(Refer to the test circuits, $0 < T_J < +125^\circ\text{C}$, $I_O=350\text{mA}$, $V_I=10\text{V}$, unless otherwise specified, $C_I = 0.33\mu\text{F}$, $C_O=0.1\mu\text{F}$)

Parameter	Symbol	Conditions	Value			Unit
			Min	Typ	Max	
Output Voltage	V_O	$I_O = 5\text{mA} \sim 350\text{mA}$ $V_I = 7 \sim 20\text{V}$	4.75	5	5.25	V
Line Regulation(Note)	ΔV_O	$I_O = 200\text{mA}$ $T_j = 25^\circ\text{C}$	$V_I = 7\text{V} \sim 25\text{V}$		100	mV
			$V_I = 8\text{V} \sim 25\text{V}$		50	
Load Regulation(Note)	ΔV_O	$T_j = 25^\circ\text{C}$	$I_O = 5\text{mA} \sim 500\text{mA}$		100	mV
			$I_O = 5\text{mA} \sim 200\text{mA}$		50	
Quiescent Current	I_Q	$T_j = 25^\circ\text{C}$			6.0	mA
Quiescent Current Change	ΔI_Q	$I_O = 5\text{mA} \sim 350\text{mA}$			0.5	mA
		$I_O = 200\text{mA}$, $V_I = 8 \sim 25\text{V}$			0.8	
Output Voltage Drift	$\Delta V / \Delta T$	$I_O = 5\text{mA}$, $T_j = 0 \sim 125^\circ\text{C}$		-0.5		mV/°C
Output Noise Voltage	V_N	$f = 10\text{Hz} \sim 100\text{KHz}$		40		μV
Ripple Rejection	RR	$f = 120\text{Hz}$, $V_I = 8 \sim 18\text{V}$		80		dB
Dropout Voltage	V_D	$T_j = 25^\circ\text{C}$, $I_O = 500\text{mA}$		2		V
Short Circuit Current	I_{SC}	$T_j = 25^\circ\text{C}$, $V_I = 35\text{V}$		800		mA
Peak Current	I_{PK}	$T_j = 25^\circ\text{C}$		900		mA

Notes:

Load and line regulation are specified at constant junction temperature. Change in V_O due to heating effects must be taken into account separately. Pulse testing with low duty is used.

Electrical Characteristics (78M06)

(Refer to the test circuits, $0 < T_j < +125^{\circ}\text{C}$, $I_o=350\text{mA}$, $V_i=11\text{V}$, unless otherwise specified, $C_i = 0.33\mu\text{F}$, $C_o=0.1\mu\text{F}$)

Parameter	Symbol	Conditions	Value			Unit	
			Min	Typ	Max		
Output Voltage	V_o	$I_o = 5\text{mA} \sim 350\text{mA}$ $V_i = 8 \sim 21\text{V}$	5.7	6	6.3	V	
Line Regulation(Note)	ΔV_o	$I_o = 200\text{mA}$ $T_j = 25^{\circ}\text{C}$	$V_i = 8\text{V} \sim 25\text{V}$			100	mV
			$V_i = 9\text{V} \sim 25\text{V}$			50	
Load Regulation(Note)	ΔV_o	$T_j = 25^{\circ}\text{C}$	$I_o = 5\text{mA} \sim 500\text{mA}$			120	mV
			$I_o = 5\text{mA} \sim 200\text{mA}$			60	
Quiescent Current	I_Q	$T_j = 25^{\circ}\text{C}$				6.0	mA
Quiescent Current Change	ΔI_Q	$I_o = 5\text{mA} \sim 350\text{mA}$				0.5	mA
		$I_o = 200\text{mA}$, $V_i = 9 \sim 25\text{V}$				0.8	
Output Voltage Drift	$\Delta V / \Delta T$	$I_o = 5\text{mA}$, $T_j = 0 \sim 125^{\circ}\text{C}$		-0.5			mV/ $^{\circ}\text{C}$
Output Noise Voltage	V_N	$f = 10\text{Hz} \sim 100\text{KHz}$		45			μV
Ripple Rejection	RR	$f = 120\text{Hz}$, $V_i = 9 \sim 19\text{V}$		80			dB
Dropout Voltage	V_D	$T_j = 25^{\circ}\text{C}$, $I_o = 500\text{mA}$		2			V
Short Circuit Current	I_{SC}	$T_j = 25^{\circ}\text{C}$, $V_i = 35\text{V}$		800			mA
Peak Current	I_{PK}	$T_j = 25^{\circ}\text{C}$		900			mA

Notes:

Load and line regulation are specified at constant junction temperature. Change in V_o due to heating effects must be taken into account separately. Pulse testing with low duty is used.

Electrical Characteristics (78M08)

(Refer to the test circuits, $0 < T_j < +125^{\circ}\text{C}$, $I_o=350\text{mA}$, $V_i=14\text{V}$, unless otherwise specified, $C_i = 0.33\mu\text{F}$, $C_o=0.1\mu\text{F}$)

Parameter	Symbol	Conditions	Value			Unit
			Min	Typ	Max	
Output Voltage	V_o	$I_o = 5\text{mA} \sim 350\text{mA}$ $V_i = 10.5 \sim 23\text{V}$	7.6	8	8.4	V
Line Regulation(Note)	ΔV_o	$I_o = 200\text{mA}$ $T_j = 25^{\circ}\text{C}$	$V_i = 10.5\text{V} \sim 25\text{V}$		100	mV
			$V_i = 11\text{V} \sim 25\text{V}$		50	
Load Regulation(Note)	ΔV_o	$T_j = 25^{\circ}\text{C}$	$I_o = 5\text{mA} \sim 500\text{mA}$		160	mV
			$I_o = 5\text{mA} \sim 200\text{mA}$		80	
Quiescent Current	I_q	$T_j = 25^{\circ}\text{C}$			6.0	mA
Quiescent Current Change	ΔI_q	$I_o = 5\text{mA} \sim 350\text{mA}$			0.5	mA
		$I_o = 200\text{mA}$, $V_i = 10.5 \sim 25\text{V}$			0.8	
Output Voltage Drift	$\Delta V / \Delta T$	$I_o = 5\text{mA}$, $T_j = 0 \sim 125^{\circ}\text{C}$		-0.8		mV/ $^{\circ}\text{C}$
Output Noise Voltage	V_N	$f = 10\text{Hz} \sim 100\text{KHz}$		52		μV
Ripple Rejection	RR	$f = 120\text{Hz}$, $V_i = 11.5 \sim 21.5\text{V}$		80		dB
Dropout Voltage	V_D	$T_j = 25^{\circ}\text{C}$, $I_o = 500\text{mA}$		2		V
Short Circuit Current	I_{SC}	$T_j = 25$, $V_i = 35\text{V}$		800		mA
Peak Current	I_{PK}	$T_j = 25^{\circ}\text{C}$		900		mA

Notes:

Load and line regulation are specified at constant junction temperature. Change in V_o due to heating effects must be taken into account separately. Pulse testing with low duty is used.

Electrical Characteristics (78M09)

(Refer to the test circuits, $0 < T_j < +125^{\circ}\text{C}$, $I_o=350\text{mA}$, $V_i=15\text{V}$, unless otherwise specified, $C_i = 0.33\mu\text{F}$, $C_o=0.1\mu\text{F}$)

Parameter	Symbol	Conditions	Value			Unit
			Min	Typ	Max	
Output Voltage	V_o	$I_o = 5\text{mA} \sim 350\text{mA}$ $V_i = 11.5 \sim 24\text{V}$	8.45	9	9.55	V
Line Regulation(Note)	ΔV_o	$I_o = 200\text{mA}$ $T_j = 25^{\circ}\text{C}$	$V_i = 11.5\text{V} \sim 25\text{V}$		100	mV
			$V_i = 12\text{V} \sim 25\text{V}$		50	
Load Regulation(Note)	ΔV_o	$T_j = 25^{\circ}\text{C}$	$I_o = 5\text{mA} \sim 500\text{mA}$		180	mV
			$I_o = 5\text{mA} \sim 200\text{mA}$		90	
Quiescent Current	I_q	$T_j = 25^{\circ}\text{C}$			6.0	mA
Quiescent Current Change	ΔI_q	$I_o = 5\text{mA} \sim 350\text{mA}$			0.5	mA
		$I_o = 200\text{mA}$, $V_i = 11.5 \sim 25\text{V}$			0.8	
Output Voltage Drift	$\Delta V / \Delta T$	$I_o = 5\text{mA}$, $T_j = 0 \sim 125^{\circ}\text{C}$		-0.8		mV/ $^{\circ}\text{C}$
Output Noise Voltage	V_N	$f = 10\text{Hz} \sim 100\text{KHz}$		52		μV
Ripple Rejection	RR	$f = 120\text{Hz}$, $V_i = 12.5 \sim 22.5\text{V}$		80		dB
Dropout Voltage	V_D	$T_j = 25^{\circ}\text{C}$, $I_o = 500\text{mA}$		2		V
Short Circuit Current	I_{SC}	$T_j = 25$, $V_i = 35\text{V}$		800		mA
Peak Current	I_{PK}	$T_j = 25^{\circ}\text{C}$		900		mA

Notes:

Load and line regulation are specified at constant junction temperature. Change in V_o due to heating effects must be taken into account separately. Pulse testing with low duty is used.

Electrical Characteristics (78M12)

(Refer to the test circuits, $0 < T_j < +125^{\circ}\text{C}$, $I_o=350\text{mA}$, $V_i=19\text{V}$, unless otherwise specified, $C_i = 0.33\mu\text{F}$, $C_o=0.1\mu\text{F}$)

Parameter	Symbol	Conditions	Value			Unit
			Min	Typ	Max	
Output Voltage	V_o	$I_o = 5\text{mA} \sim 350\text{mA}$ $V_i = 14.5 \sim 27\text{V}$	11.4	12	12.6	V
Line Regulation(Note)	ΔV_o	$I_o = 200\text{mA}$ $T_j = 25^{\circ}\text{C}$	$V_i = 14.5\text{V} \sim 30\text{V}$		100	mV
			$V_i = 16\text{V} \sim 30\text{V}$		50	
Load Regulation(Note)	ΔV_o	$T_j = 25^{\circ}\text{C}$	$I_o = 5\text{mA} \sim 500\text{mA}$		240	mV
			$I_o = 5\text{mA} \sim 200\text{mA}$		120	
Quiescent Current	I_Q	$T_j = 25^{\circ}\text{C}$			6.0	mA
Quiescent Current Change	ΔI_Q	$I_o = 5\text{mA} \sim 350\text{mA}$			0.5	mA
		$I_o = 200\text{mA}$, $V_i = 14.5 \sim 30\text{V}$			0.8	
Output Voltage Drift	$\Delta V / \Delta T$	$I_o = 5\text{mA}$, $T_j = 0 \sim 125^{\circ}\text{C}$		-0.8		mV/ $^{\circ}\text{C}$
Output Noise Voltage	V_N	$f = 10\text{Hz} \sim 100\text{KHz}$		75		μV
Ripple Rejection	RR	$f = 120\text{Hz}$, $V_i = 15 \sim 25\text{V}$		80		dB
Dropout Voltage	V_D	$T_j = 25^{\circ}\text{C}$, $I_o = 500\text{mA}$		2		V
Short Circuit Current	I_{SC}	$T_j = 25^{\circ}\text{C}$, $V_i = 35\text{V}$		800		mA
Peak Current	I_{PK}	$T_j = 25^{\circ}\text{C}$		900		mA

Notes:

Load and line regulation are specified at constant junction temperature. Change in V_o due to heating effects must be taken into account separately. Pulse testing with low duty is used.

Electrical Characteristics (78M15)

(Refer to the test circuits, $0 < T_j < +125^{\circ}\text{C}$, $I_o=350\text{mA}$, $V_i=23\text{V}$, unless otherwise specified, $C_i = 0.33\mu\text{F}$, $C_o=0.1\mu\text{F}$)

Parameter	Symbol	Conditions	Value			Unit
			Min	Typ	Max	
Output Voltage	V_o	$I_o = 5\text{mA} \sim 350\text{mA}$ $V_i = 17.5 \sim 30\text{V}$	14.25	15	15.75	V
Line Regulation(Note)	ΔV_o	$I_o = 200\text{mA}$ $T_j = 25^{\circ}\text{C}$	$V_i = 17.5\text{V} \sim 30\text{V}$		100	mV
			$V_i = 20\text{V} \sim 30\text{V}$		50	
Load Regulation(Note)	ΔV_o	$T_j = 25^{\circ}\text{C}$	$I_o = 5\text{mA} \sim 500\text{mA}$		300	mV
			$I_o = 5\text{mA} \sim 200\text{mA}$		150	
Quiescent Current	I_q	$T_j = 25^{\circ}\text{C}$			6.0	mA
Quiescent Current Change	ΔI_q	$I_o = 5\text{mA} \sim 350\text{mA}$			0.5	mA
		$I_o = 200\text{mA}$, $V_i = 17.5 \sim 30\text{V}$			0.8	
Output Voltage Drift	$\Delta V / \Delta T$	$I_o = 5\text{mA}$, $T_j = 0 \sim 125^{\circ}\text{C}$		-1.0		mV/ $^{\circ}\text{C}$
Output Noise Voltage	V_N	$f = 10\text{Hz} \sim 100\text{KHz}$		100		μV
Ripple Rejection	RR	$f = 120\text{Hz}$, $V_i = 18.5 \sim 28.5\text{V}$		70		dB
Dropout Voltage	V_D	$T_j = 25^{\circ}\text{C}$, $I_o = 500\text{mA}$		2		V
Short Circuit Current	I_{SC}	$T_j = 25^{\circ}\text{C}$, $V_i = 35\text{V}$		800		mA
Peak Current	I_{PK}	$T_j = 25^{\circ}\text{C}$		900		mA

Notes:

Load and line regulation are specified at constant junction temperature. Change in V_o due to heating effects must be taken into account separately. Pulse testing with low duty is used.

Electrical Characteristics (78M18)

(Refer to the test circuits, $0 < T_j < +125^{\circ}\text{C}$, $I_o=350\text{mA}$, $V_i=26\text{V}$, unless otherwise specified, $C_i = 0.33\mu\text{F}$, $C_o=0.1\mu\text{F}$)

Parameter	Symbol	Conditions	Value			Unit
			Min	Typ	Max	
Output Voltage	V_o	$I_o = 5\text{mA} \sim 350\text{mA}$ $V_i = 20.5 \sim 33\text{V}$	17.1	18	18.9	V
Line Regulation(Note)	ΔV_o	$I_o = 200\text{mA}$ $T_j = 25^{\circ}\text{C}$	$V_i = 21\text{V} \sim 33\text{V}$		100	mV
			$V_i = 24\text{V} \sim 33\text{V}$		50	
Load Regulation(Note)	ΔV_o	$T_j = 25^{\circ}\text{C}$	$I_o = 5\text{mA} \sim 500\text{mA}$		360	mV
			$I_o = 5\text{mA} \sim 200\text{mA}$		180	
Quiescent Current	I_Q	$T_j = 25^{\circ}\text{C}$			6.0	mA
Quiescent Current Change	ΔI_Q	$I_o = 5\text{mA} \sim 350\text{mA}$			0.5	mA
		$I_o = 200\text{mA}$, $V_i = 21 \sim 33\text{V}$			0.8	
Output Voltage Drift	$\Delta V / \Delta T$	$I_o = 5\text{mA}$, $T_j = 0 \sim 125^{\circ}\text{C}$		-1.2		mV/ $^{\circ}\text{C}$
Output Noise Voltage	V_N	$f = 10\text{Hz} \sim 100\text{KHz}$		100		μV
Ripple Rejection	RR	$f = 120\text{Hz}$, $V_i = 22 \sim 32\text{V}$		70		dB
Dropout Voltage	V_D	$T_j = 25^{\circ}\text{C}$, $I_o = 500\text{mA}$		2		V
Short Circuit Current	I_{SC}	$T_j = 25$, $V_i = 35\text{V}$		800		mA
Peak Current	I_{PK}	$T_j = 25^{\circ}\text{C}$		900		mA

Notes:

Load and line regulation are specified at constant junction temperature. Change in V_o due to heating effects must be taken into account separately. Pulse testing with low duty is used.

Electrical Characteristics (78M24)

(Refer to the test circuits, $0 < T_j < +125^{\circ}\text{C}$, $I_o=350\text{mA}$, $V_i=33\text{V}$, unless otherwise specified, $C_i = 0.33\mu\text{F}$, $C_o=0.1\mu\text{F}$)

Parameter	Symbol	Conditions	Value			Unit
			Min	Typ	Max	
Output Voltage	V_o	$I_o = 5\text{mA} \sim 350\text{mA}$ $V_i = 27 \sim 38\text{V}$	22.8	24	25.2	V
Line Regulation(Note)	ΔV_o	$I_o = 200\text{mA}$ $T_j = 25^{\circ}\text{C}$	$V_i = 27\text{V} \sim 38\text{V}$		100	mV
			$V_i = 28\text{V} \sim 38\text{V}$		50	
Load Regulation(Note)	ΔV_o	$T_j = 25^{\circ}\text{C}$	$I_o = 5\text{mA} \sim 500\text{mA}$		480	mV
			$I_o = 5\text{mA} \sim 200\text{mA}$		240	
Quiescent Current	I_Q	$T_j = 25^{\circ}\text{C}$			6.0	mA
Quiescent Current Change	ΔI_Q	$I_o = 5\text{mA} \sim 350\text{mA}$			0.5	mA
		$I_o = 200\text{mA}$, $V_i = 27 \sim 38\text{V}$			0.8	
Output Voltage Drift	$\Delta V / \Delta T$	$I_o = 5\text{mA}$, $T_j = 0 \sim 125^{\circ}\text{C}$		-1.2		mV/ $^{\circ}\text{C}$
Output Noise Voltage	V_N	$f = 10\text{Hz} \sim 100\text{KHz}$		170		μV
Ripple Rejection	RR	$f = 120\text{Hz}$, $V_i = 28 \sim 38\text{V}$		70		dB
Dropout Voltage	V_D	$T_j = 25^{\circ}\text{C}$, $I_o = 500\text{mA}$		2		V
Short Circuit Current	I_{SC}	$T_j = 25$, $V_i = 35\text{V}$		800		mA
Peak Current	I_{PK}	$T_j = 25^{\circ}\text{C}$		900		mA

Notes:

Load and line regulation are specified at constant junction temperature. Change in V_o due to heating effects must be taken into account separately. Pulse testing with low duty is used.

SOT-223 Package Information

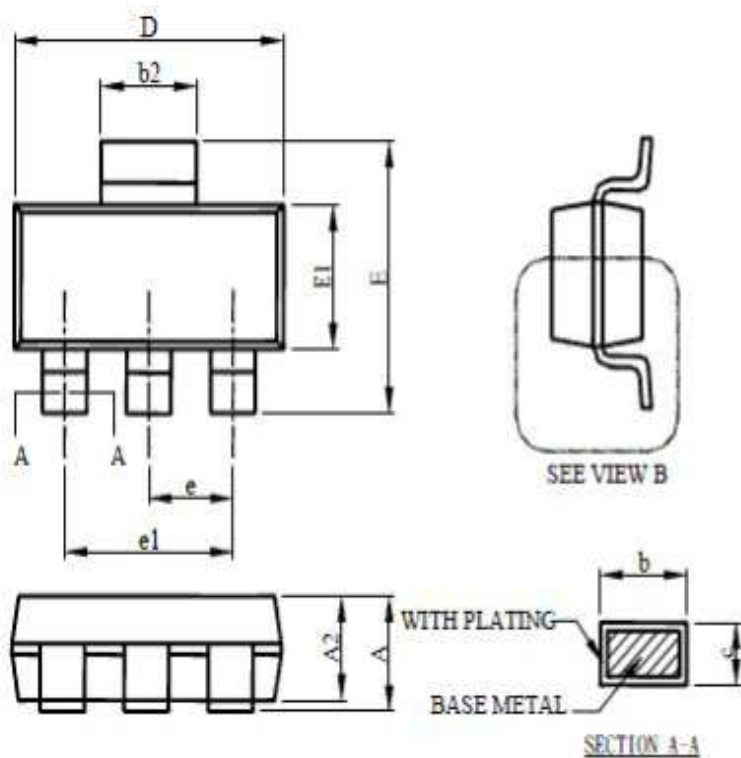

SYMBOL	SOT-223	
	MILLIMETERS	
	MIN.	MAX.
A		1.80
A1	0.02	0.10
A2	1.55	1.65
b	0.66	0.84
b2	2.90	3.10
c	0.23	0.33
D	6.30	6.70
E	6.70	7.30
E1	3.30	3.70
e	2.30 BSC	
e1	4.60 BSC	
L	0.90	
θ	0°	8°

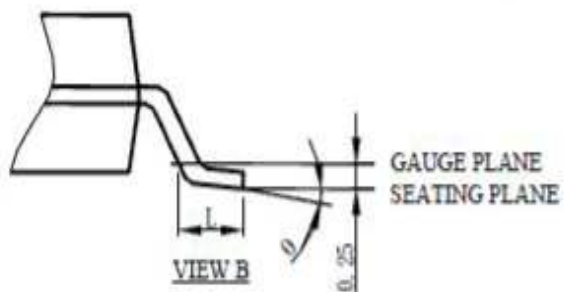

TO-252 Package Information

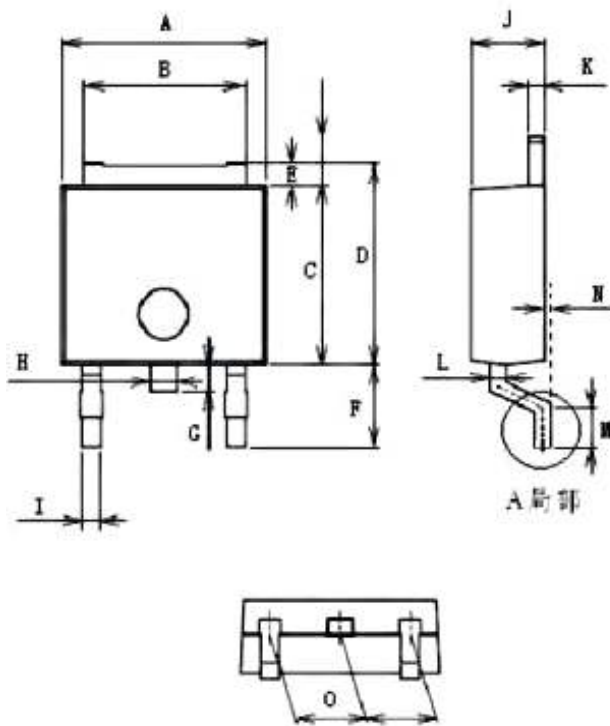

Unit: mm

Item	Min	Max
A	6.40	6.70
B	5.20	5.40
C	6.00	6.30
D	6.55	6.85
E	0.45	0.60
F	3.07	3.35
G	0.85	1.05
H	0.75	0.95
I	0.55	0.75
J	2.20	2.40
K	0.43	0.58
L	0.43	0.58
M	0.90	1.10
N	0.90	1.10
O	2.20	2.40