

PART NUMBER	REV	FIRST USED
567489-1	D	854400-1
567489-2	D	565435-5
567489-3	D	354500-1

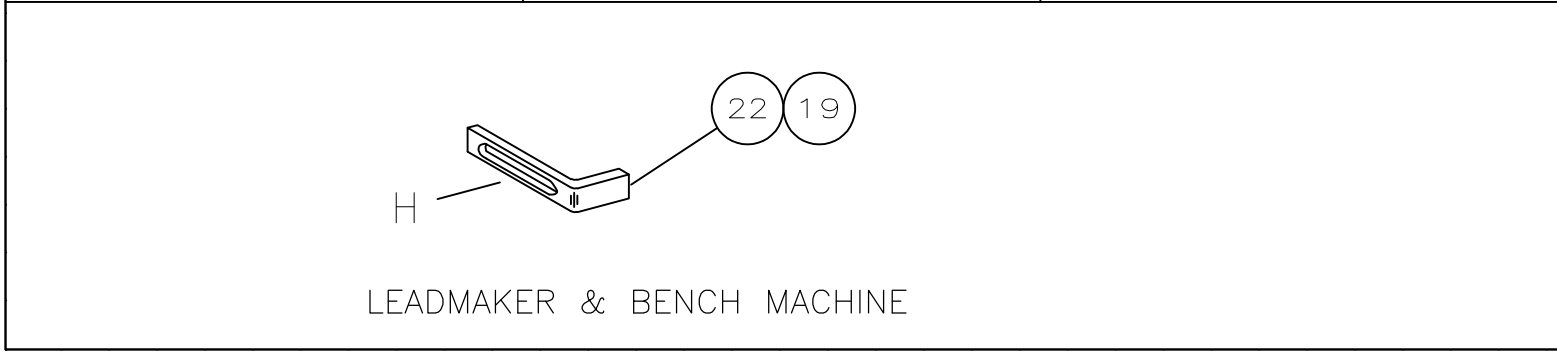

- 1 RECOMMENDED SPARE PARTS.
- 2 GREASE LIGHTLY.
- 3 GUARD MUST BE IN PLACE WHEN OPERATING APPLICATOR IN AMP-O-LECTRIC MACHINE.
- 4 LUBRICATE DAILY USING NO. 20 MACHINE OIL.
- 5 STABILIZER CRIMPER SHAFT MUST BE TURNED SO THAT LETTER SHOWING (RIGHT SIDE OF RAM) MATCHES WIRE DISC PAD BEING USED (A,B, OR C) AS SHOWN

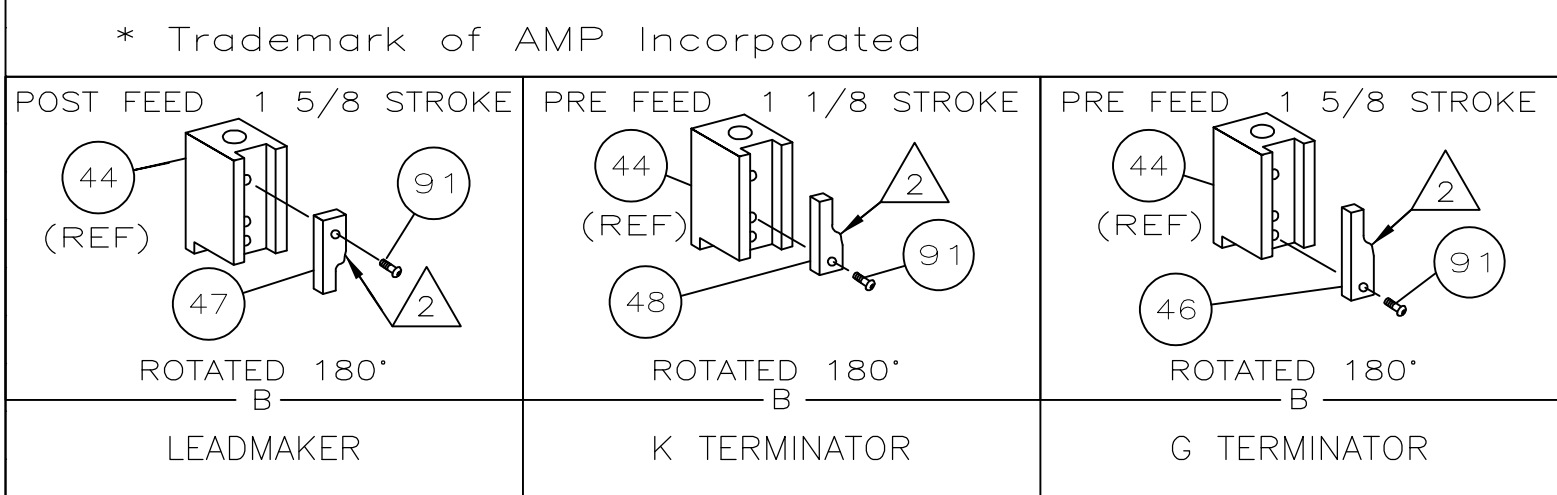
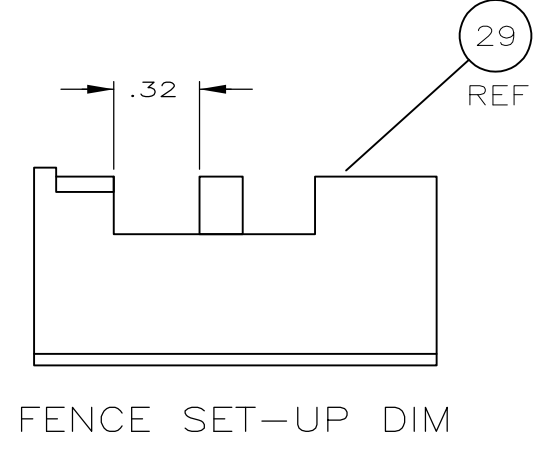
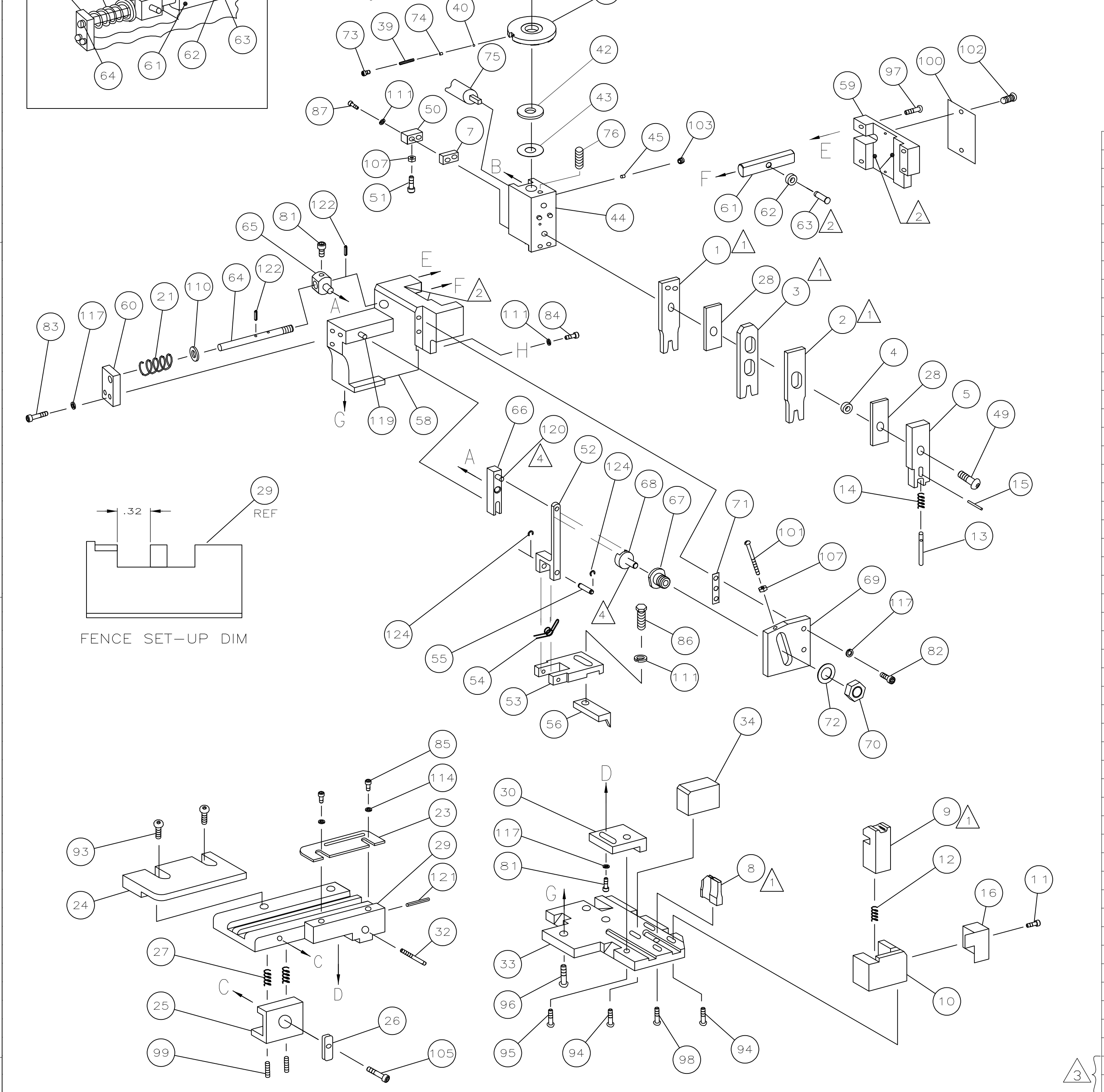
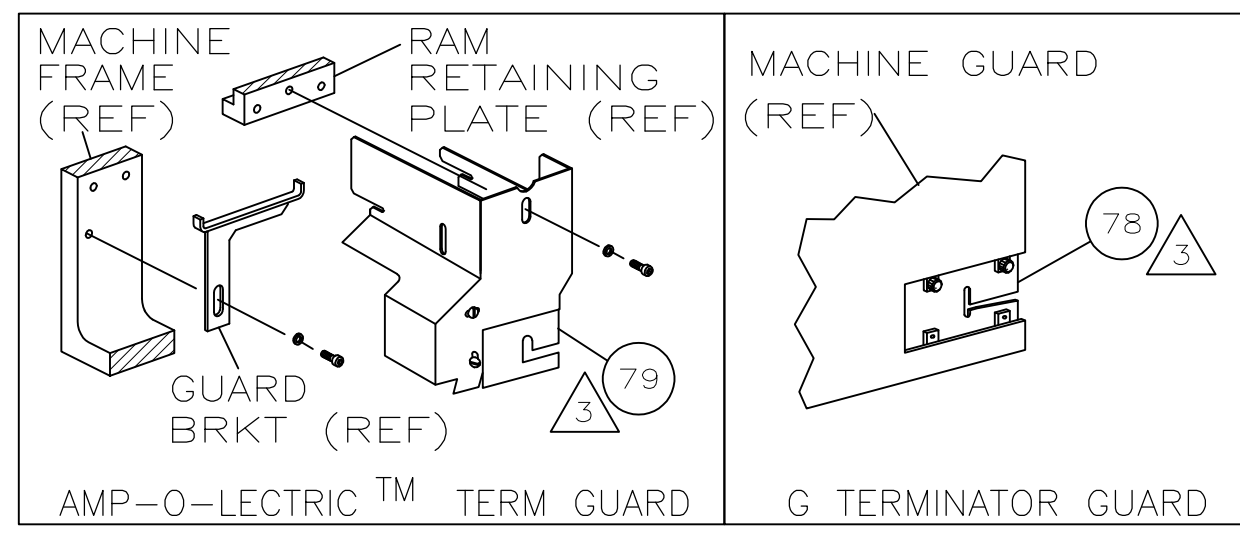
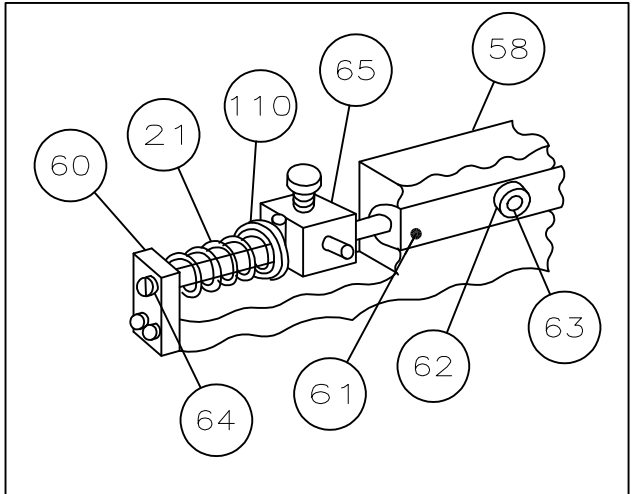
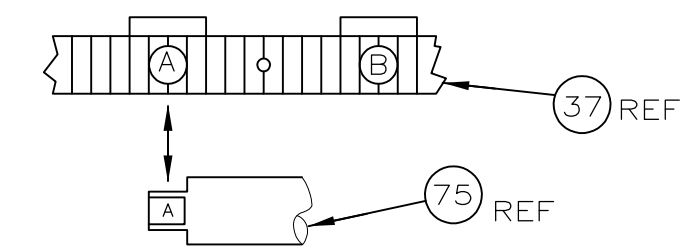

TERMINAL NAME:  
.070 SERIES TAB CONTACT

PAD LTR	CRIMP HEIGHT	WIRE SIZE
A	.060 ±.002	16
B	.054 ±.002	18
C	.049 ±.002	20
D	NOT USED	

CRIMP SIZE TYPE RANGE

CRIMP	SIZE	TYPE	RANGE
WIRE	.090	F	20-16
INSUL	.102	0	.047-.087

FEED .469 APPL INST A18040 SET UP GAGE 458637-1 LAYOUT L1488

WIRE STRIP LENGTH .110-.130

ITEM NO	DESCRIPTION	ITEM NO
-1	LEADMAKER	MECH-POST FEED
-2	BENCH MODEL K	MECH-PRE FEED
-3	BENCH MODEL G	MECH-PRE FEED

TERM APPL SPEC 114-5157

QTY REQD PER ASSY	PART NO	DESCRIPTION	ITEM NO
			129
			128
			127
			126
			125
2	21045-3	RING,RET "C"(Ø.187)FD FING PIN	124
			123
2	5-21028-1	PIN,SLT SPR(Ø.125x.50)ADJ ROD	122
1	4-21028-0	PIN,SLT SPR(Ø.093x.75)ST GDE PL	121
1	1-21030-1	PIN,DOWEL(Ø.187x.50)LEVER	120
1	1-21030-6	PIN,DOWEL(Ø.187x1.25)HOUSING	119
			118
5	21024-5	WASHER, LOCK(#10)ADJ BLOCK	117
			116
			115
2	21024-2	WASHER,LOCK(#4)FRONT STP GUIDE	114
			113
			112
4	21024-4	WASHER,LOCK(#8)STRIPPER	111
1	21899-4	WASHER,FLAT(Ø5/16)SCREW ADJ	110
			109
			108
2	21018-5	NUT,HEX(6-32)FEED ADJ	107
			106
1	22353-8	SCR,SKT SET(1/4-20x.25)DRAG LEVER	105
			104
1	21009-2	SCR,SKT SET(1/4-20x.25 LW)RAM	103
2	21017-2	SCR,DRIVE(#2x.19)ID PLATE	102
1	6-23715-5	SCR,PAN HD(6-32x1.50)FEED ADJ	101
1	461264-1	PLATE, IDENTIFICATION	100
2	5-21006-6	SCR,SET(10-32x.75)DRAG	99
1	22733-8	SCR,BHC(8-32x.38 LW)ANVIL	98
2	2-21002-9	SCR,BHC(10-32x.75)CAP	97
3	2-22733-8	SCR,BHC(1/4-20x.62)HOUSING	96
1	2-21002-7	SCR,BHC(10-32x.50)SG ADJ BLOCK	95
4	2-21002-2	SCR,BHC(8-32x.50)SHEAR	94
2	2-21002-1	SCR,BHC(8-32x.38)R STRIP GUIDE	93
			92
1	1-21002-7	SCR,BHC(6-32x.38)CAM	91
			90
			89
			88
2	2-21000-8	SCR,SHC(8-32x.62)DEP-HOLD	87
1	2-22603-0	SCR,HEX HD(8-32x.31)FEED FINGER	86
2	1-21000-3	SCR,SHC(4-40x.25)F ST GUIDE	85
1	2-21000-7	SCR,SHC(8-32x.50)STRIPPER	84
2	3-21000-7	SCR,SHC(10-32x.75)FEED ROD GD	83
2	3-21000-6	SCR,SHC(10-32x.62)FEED ADJ BLK	82
2	3-21000-4	SCR,SHC(10-32x.38)SG ADJ BL	81
			80
-	REF	GUARD, WINDOW	79
REF		INSERT, GUARD	78
			77
1	22859-7	PLUNGER, SPRING	76
1	1-453412-0	SHAFT, STABILIZER	75
2	690603-1	SPRING, ASSIST	74
2	23030-1	SCR,SHC(6-32x.25)CP DISC	73
1	458109-1	WASHER, SPECIAL	72
1	690517-1	SPACER	71
			70
			69
			68
			67
			66
			65
			64
			63
			62
			61
			60
			59
			58
			57
			56
			55
			54
			53
			52
			51
			50
			49
			48
			47
			46
			45
			44
			43
			42
			41
			40
			39
			38
			37
			36
			35
			34
			33
			32
			31
			30
			29
			28
			27
			26
			25
			24
			23
			22
			21
			20
			19
			18
			17
			16
			15
			14
			13
			12
			11
			10
			9
			8
			7
			6
			5
			4
			3
			2
			1

LOC	DIST	REV	DESCRIPTION	DATE	DRN	APVO
A	66	D1	ECR-07-017642	7-2007	MY	GB

QTY REQD PER ASSY	PART NO	DESCRIPTION	ITEM NO
			70
			69
			68
			67
			66
			65
			64
			63
			62
			61
			60
			59
			58
			57
			56
			55
			54
			53
			52
			51
			50
			49
			48
			47
			46
			45
			44
			43
			42
			41
			40
			39
			38
			37
			36
			35
			34
			33
			32
			31
			30
			29
			28
			27
			26
			25
			24
			23
			22
			21
			20
			19
			18
			17
			16
			15
			14
			13
			12
			11
			10
			9
			8
			7
			6
			5
			4
			3
			2
			1

THIS DRAWING IS A CONTROLLED DOCUMENT.

DMN P. MATHIAS 2/12/93  
CHK C. ERISMAN 2-17-93  
APRD B. WOLFF 2-18-93

Tyco Electronics Corporation  
Harrisburg, PA 17105-3608

NAME: SIDE FEED HDM APPLICATOR

PRODUCT SPEC: --  
APPLICATION SPEC: --  
WEIGHT: --

SIZE: A1  
CAGE CODE: 00779  
DRAWING NO: 567489

CUSTOMER DRAWING

SCALE: -- SHEET: 1 of 1 REV: D1