

ISL8018DEMO1Z

Demonstration Board

UG052
Rev.3.00
Aug 3, 2017

Description

The ISL8018DEMO1Z is intended for point-of-load applications sourcing from 2.7V to 5.5V. The ISL8018DEMO1Z is a simple, small form factor demonstration board for a quick and easy performance demonstration of the [ISL8018](#) low quiescent, high efficiency synchronous buck regulator.

The ISL8018DEMO1Z is a 20.07mmx16.51mm 4-layer FR4 board with 2oz copper in all layers. The complete converter occupies 115.613mm² area.

Specifications

This board has been configured and optimized for the following operation conditions:

- $V_{IN} = 2.7$ to $5.5V$
- $V_{OUT} = 1.8V$
- $I_{OUTMAX} = 8A$
- $f_{SW} = 1MHz$
- Efficiency at 50% load: >90%
- Output ripple: <1% of output voltage (PWM mode)
- Operating junction temperature range: $-40^{\circ}C$ to $+125^{\circ}C$

Key Features

- High efficiency synchronous buck regulator with up to 97% efficiency
- $\pm 10\%$ output voltage margining
- Adjustable current limit
- Start-up with prebiased output
- Internal soft-start - 1ms or adjustable
- Soft-stop output discharge while disabled
- Adjustable frequency from 500kHz to 4MHz - default at 1MHz
- External synchronization up to 4MHz - master to slave phase shifting capability

Related Literature

- For a full list of related documents, visit our website - [ISL8018](#) product page

Ordering Information

PART NUMBER	DESCRIPTION
ISL8018DEMO1Z	Demonstration board

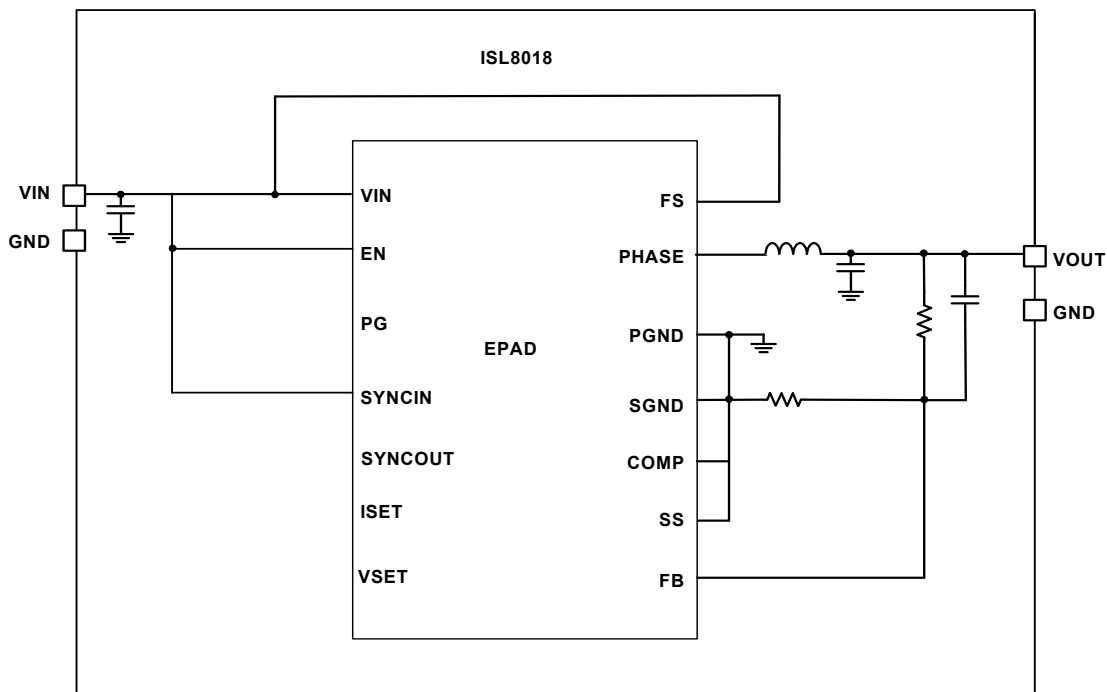

FIGURE 1. ISL8018DEMO1Z BLOCK DIAGRAM

Recommended Equipment

The following materials are recommended for testing:

- 0V to 10V power supply with at least 15A source current capability or 5V battery
- Electronic loads capable of sinking current up to 10A
- Digital Multimeters (DMMs)
- 100MHz quad-trace oscilloscope
- Signal generator

Quick Setup Guide

1. Ensure that the circuit is correctly connected to the supply and loads before applying any power.
2. Connect the bias supply to VIN, the plus terminal to VIN, and the negative return to PGND.
3. Connect the output load to VOUT, the plus terminal to VO, and the negative return to PGND.
4. Verify the output voltage is 1.8V for V_O .

Functional Description

The ISL8018DEMO1Z board provides a simple platform for the ISL8018.

This device is a monolithic, synchronous step-down DC/DC converter that can deliver up to 8A of continuous output current from 2.7V to 5.5V input supply. It uses peak current mode control architecture to allow low duty cycle operation. The device operates at 1MHz switching frequency.

PCB Layout Guidelines

The PCB layout is a very important design step to ensure the converter works well. For ISL8018, the power loop is composed of the output inductor L's, the output capacitor C_{OUT} , the PHASE pins, and the PGND pin. It is necessary to make the power loop as small as possible and the connecting traces among them should be direct, short, and wide. The switching node of the converter, the PHASE pins, and the traces connected to the node are very noisy, so keep the voltage feedback trace away from these noisy traces. The input capacitor should be placed as close as possible to the VIN pin and the ground of the input and output capacitors should be connected as close as possible. The heat of the IC is mainly dissipated through the thermal pad. Maximizing the copper area connected to the thermal pad is preferable. In addition, a solid ground plane is helpful for better EMI performance. It is recommended to add at least five vias ground connection within the pad for the best thermal relief.

ISL8018DEMO1Z Demonstration Board

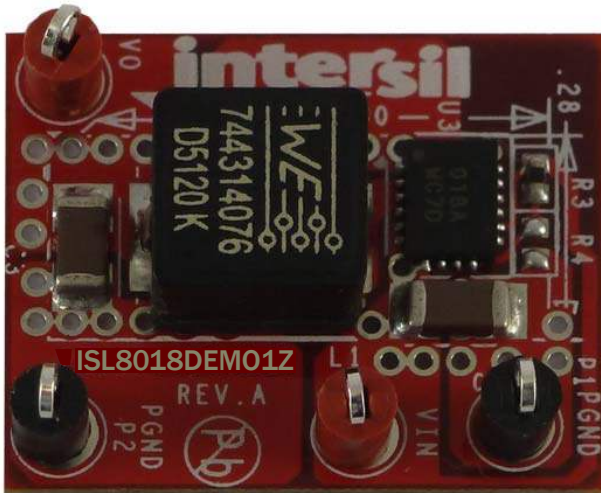

FIGURE 2. TOP SIDE

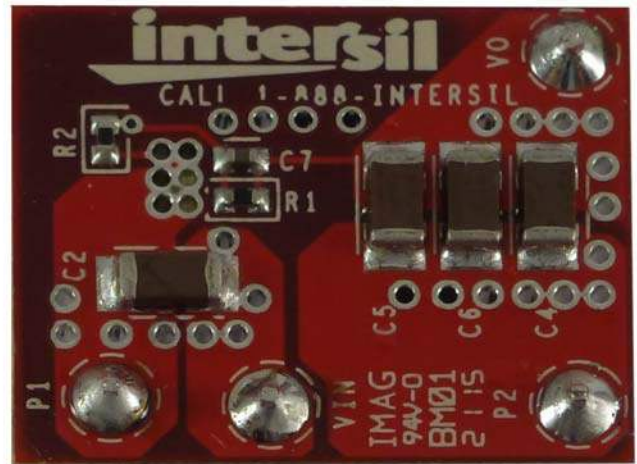

FIGURE 3. BOTTOM SIDE

Board Layout

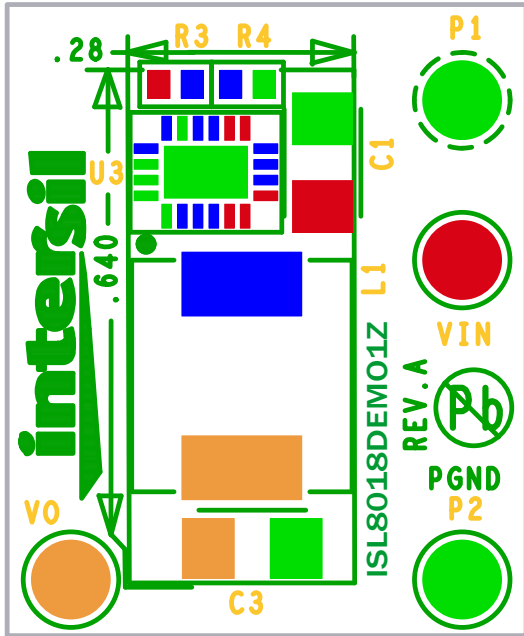

FIGURE 5. TOP COMPONENTS

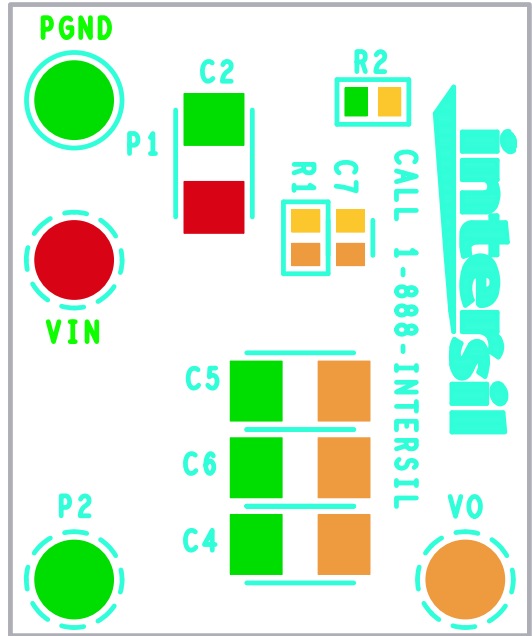

FIGURE 6. BOTTOM SILK SCREEN

Typical Performance Curves $V_{IN} = 5.5V, V_{OUT} = 1.8V, I_{OUT} = 8A$

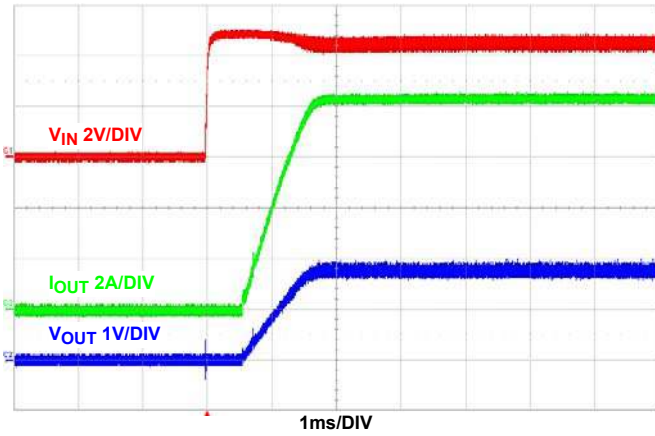

FIGURE 7. V_{IN} AT FULL LOAD

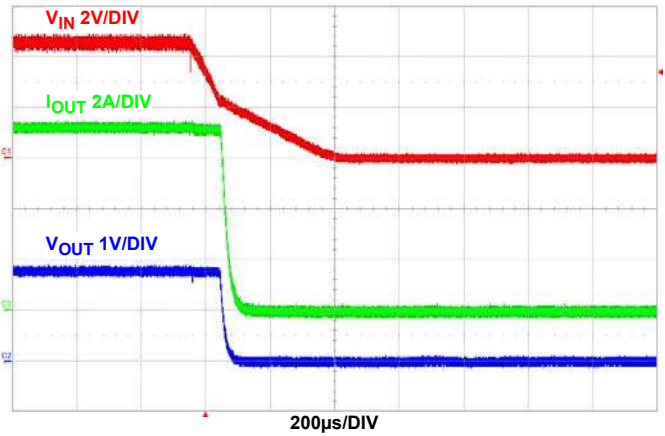

FIGURE 8. SHUTDOWN WITH V_{IN} AT FULL LOAD

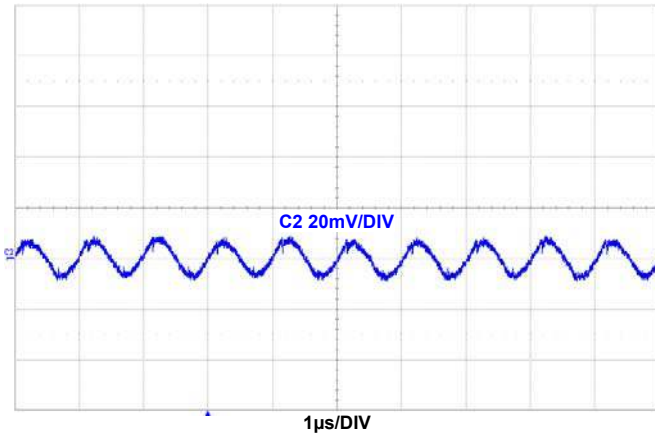

FIGURE 9. V_{OUT} RIPPLE ACROSS THE OUTPUT CAPS

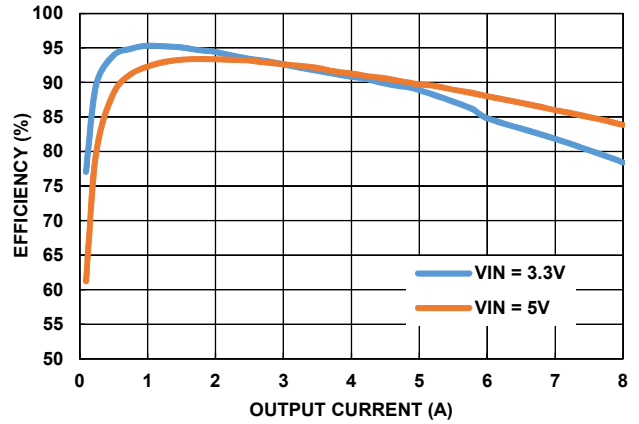

FIGURE 10. EFFICIENCY vs LOAD (1MHz PWM)

© Copyright Intersil Americas LLC 2015-2017. All Rights Reserved.
 All trademarks and registered trademarks are the property of their respective owners.

Intersil Corporation reserves the right to make changes in circuit design, software and/or specifications at any time without notice. Accordingly, the reader is cautioned to verify that the document is current before proceeding.

For information regarding Intersil Corporation and its products, see www.intersil.com