

PAGE 1/2	ISSUE 1442B	SERIES BR2	PART NUMBER R605550000
----------	-------------	------------	------------------------

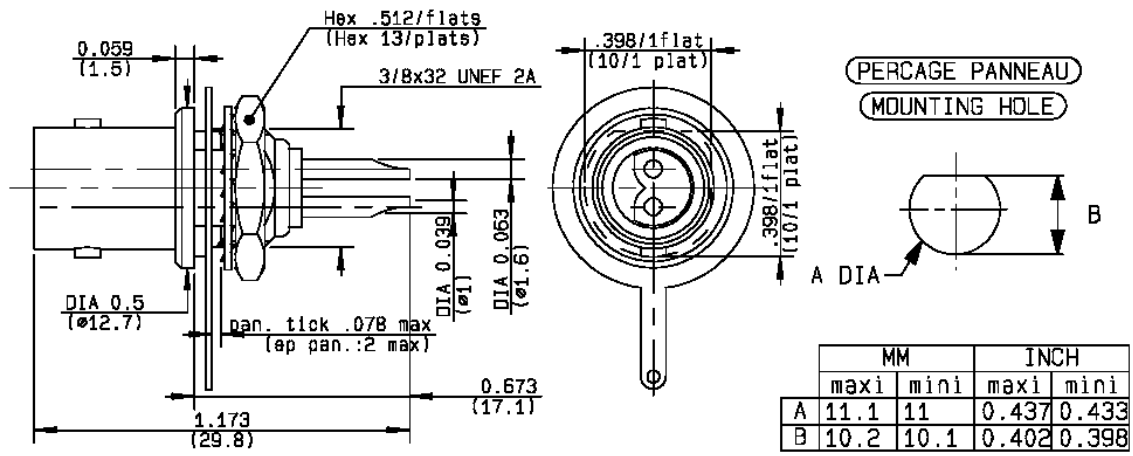

All dimensions are in mm.

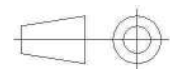

COMPONENTS	MATERIALS	PLATING (µm)
Body	BRASS	NICKEL
Center contact	BERYLLIUM COPPER	SILVER
Outer contact	-	-
Insulator	POLYAMID 6/6 (NYLON)	-
Gasket	-	-
Others parts	-	-
-	-	-
-	-	-

PAGE 2/2	ISSUE 1442B	SERIES BR2	PART NUMBER R605550000
----------	--------------------	-------------------	-------------------------------

PACKAGING

Standard	Unit	Other
1	Contact us	Contact us

ELECTRICAL CHARACTERISTICS

Impedance		50	Ω
Frequency		0-0.5	GHz
VSWR	- +	0,0000	x F(GHz) Maxi
Insertion loss		-	√F(GHz) dB Maxi
RF leakage	- (- F(GHz) dB Maxi
Voltage rating			- Veff Maxi
Dielectric withstanding voltage		1500	Veff mini
Insulation resistance		-	MΩ mini

MECHANICAL CHARACTERISTICS

Center contact retention			
Axial force – Mating End		-	N mini
Axial force – Opposite end		-	N mini
Torque		-	N.cm mini
Recommended torque			
Mating		-	N.cm
Panel nut		-	N.cm
Mating life		500	Cycles mini
Weight		0,0000	g

ENVIRONMENTAL

Operating temperature		-40/+100	°C
Hermetic seal		-	Atm.cm3/s
Panel leakage		-	

SPECIFICATION

OTHER CHARACTERISTICS

Assembly instruction:

Others:

-