

WASHER DETAIL

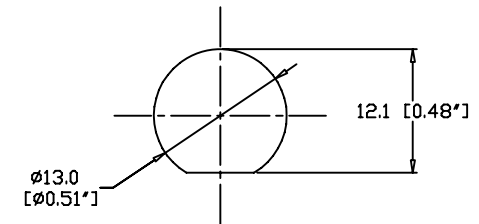
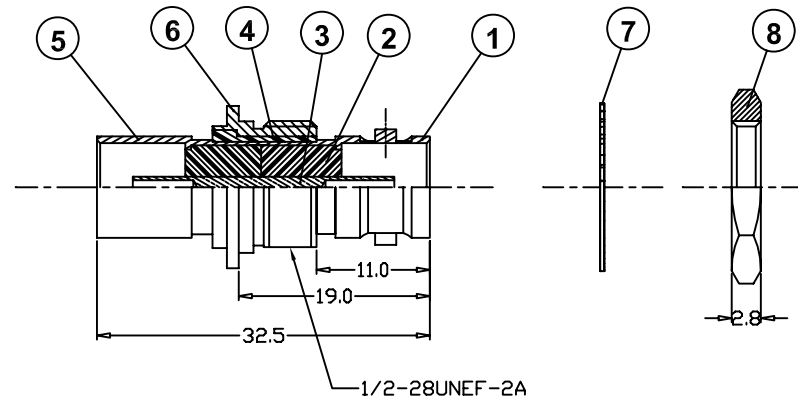

MOUNTING DETAILS  
(DIMENSIONS IN PARENTHESES ARE IN INCHES)

NOTE:

- ITEM No. 1 & 5 MUST WITHSTAND MIN 10 in-lbs TORQUE WITHOUT ROTATING WITHIN ITEM No. 6
- ITEM No. 1 & 5 MUST ISOLATED FROM ITEM No. 6
- IMPEDANCY: 75 ΩHM
- FREQUENCY RANGE: DC-3GHz

8	HN16-1/2-28X28	HN16-1/2-28X28	16 HEX NUT	01
7	LW-16/13X05	LW-16/13X05	LOCK WASHER	02
6	B7925-6-C	B7925-6-C	HOUSING	01
5	A000410-1-B	A000410-1-B	BODY	01
4	B7925-4-A	B7925-4-A	INSULATOR	01
3	B7900-4	B7900-4	CONTACT PIN	01
2	B7996ZZ-3T-75	B7996ZZ-3T-75	INSULATOR	02
1	B7925-1-B	B7925-1-B	BODY	01

UNLESS OTHERWISE SPECIFIED TOLERANCE TO BE		THIS DOCUMENT IS THE PROPERTY OF AMPHENOL AUSTRALIA PTY. LTD.. NO PART THEREOF MAY BE REPRODUCED AND USED WITHOUT THE PRIOR WRITTEN CONSENT OF THE OWNER		0	FIRST ISSUE	M.N.H.	14-09-10	----
LINEAR	ANGULAR			REV.	CHANGE DETAILS	BY	DATE	CHG/No
X ± 0.50	X' ± 1°	CAD FILE: 55010085100110	DRN: M.N.H.	DATE: 14-09-10	TITLE: BNC PUSH-JACK ISOLATED ADAPTOR 75 Ohm		Amphenol Australia Pty.Ltd, 2 Fireways Blvd, Keysborough, Vic3173	
X,X ± 0.20	X,X' ± 30°	MATL: REFER TO COMPONENT	CKD: T.N	DATE: 14-09-10	DRAWING NO. 55010085-100-1		SHEET 1 OF 1	
X,XX ± 0.10	X'X'X' ± 15°	DO NOT SCALE	FINISH: REFER TO COMPONENT	APP'D: P,M	DATE: 14-09-10	SCALE: 2:1 UOS		PART No AC-BNC-PJA-75T
DIMENSIONS IN MILLIMETRES		THIRD ANGLE PROJECTION		SIZE: A3				