

THE INFORMATION CONTAINED IN THIS DRAWING IS THE SOLE PROPERTY OF BUD INDUSTRIES INC. ANY REPRODUCTION IN PART OR WHOLE WITHOUT THE WRITTEN PERMISSION OF BUD INDUSTRIES INC. IS PROHIBITED.

DWG. NO.	HH-3431
ISSUE	REVISIONS
(A)	UPDATED TO REFLECT PART 10-4-05 DP

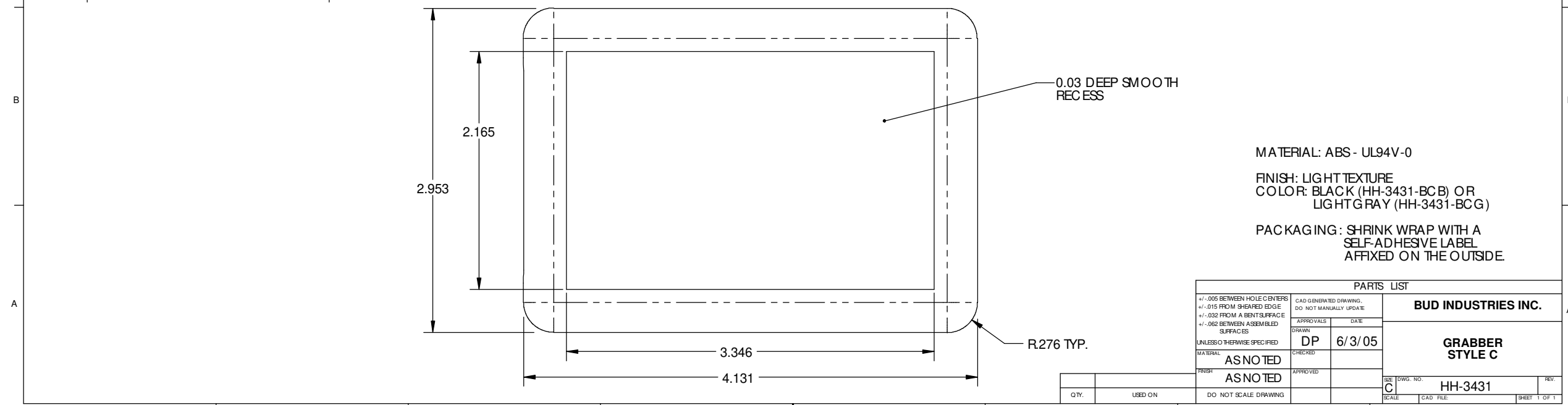
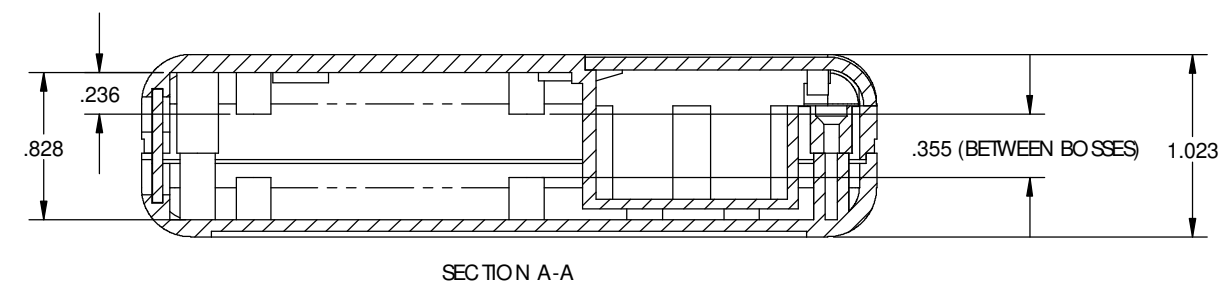
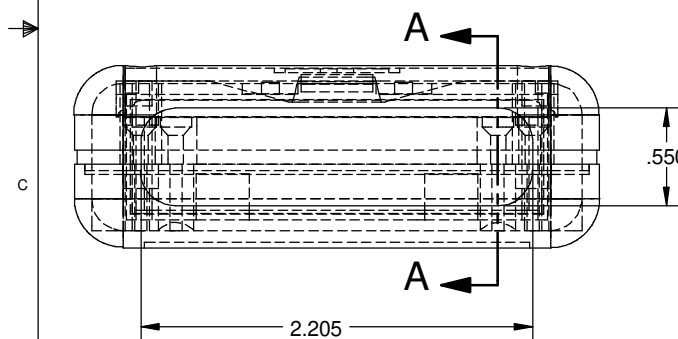
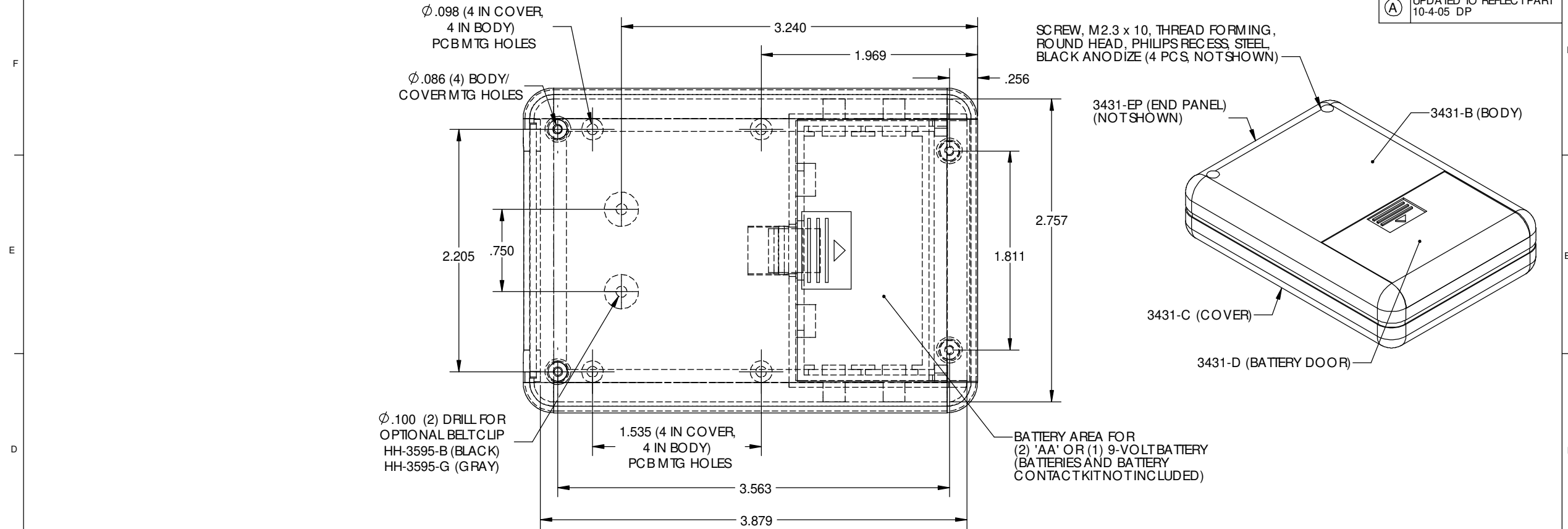

PARTS LIST		APPROVALS		DATE
BUD INDUSTRIES INC.		DRAWN	DP	6/3/05
GRABBER STYLE C		CHECKED		
AS NOTED		APPROVED		
AS NOTED				

QTY.	USED ON	SCALE	DWG. NO.	REV.
			HH-3431	